

SMART VALG FOR TUNGE LØFT OG LITEN Plass

Spesifikasjon	1	Model		FB16S-MHJZ
	2	Controller		ZAPI
	3	Løftekapasitet		kg 1600
	4	Lastesenter		mm 500
	5	Std.Løftehøyde std. mast		mm 3000
	6	Friløft (Betinget av mast)		mm 0
Dimensjon	7	Gaffelmål	LxBxT	mm 920x100x35
	8	Tilt vinkel	F/R (α°/β°)	Deg 3°/6°
	9	Mål	Lengde til gaffelbord	mm 1897
	10		Bredde	mm 1070
	11		Høyde v/senket mast	mm 1975
	12		Høyde m/hevet mast (3mtr)	mm 4010
	13		Høyde til backrest	mm 1971
	14	Svingradius		mm 1544
	15	Overheng Front		mm 371
	16/17	Dekk bredde	F/R	mm 930/0
	18	Bakkeklaring		mm 85
	19	Hjulbase		mm 1250
	20	Gaffelspreder	Min/Max	mm 200/890
	21	Reolbredde(Ast)*	1000x1200 crossways	mm 3245
22	800x1200 lengthways		mm 3370	
23	Hastighet	Kjøring(m/last)	km/h 12	
24		Kjøring(u/last)	km/h 13	
25		Løftehastighet (m/last)	km/h 280	
26		Løftehastighet (u/last)	km/h 440	
27	Klatreegenskap	m/last	% 10	
28		u/last	% 10	
29	Egenvekt	m/batteri	kg 3240	
30	Dekk	Frontx2	18x7-8	
31		Bakx1	18x7-8	
32	Motor	Fremdrift	kw 4,5	
33		Pumpe	kw 11	
34	Batteri	Standard(option)	V/Ah 48/400	
35	Hydr.Driftstrykk		Mpa 14,5	



MAXIMAL er kjent for smarte, driftsikre og rimelige logistikk-løsninger. FB16S er utstyrt med ZAPI ACE2 controller, lett tilgjengelig og godt beskyttet. Svært lav svingradius, gode klatreegenskaper og stor batterikapasitet.





SPECIFICATION

Rear Drive 3-wheel Electric Forklift 1.6ton

specification	1	Model		FB16S-MHJZ	
	2	Power		ZAPI	
	3	Rated capacity	kg	1600	
	4	Load centre	mm	500	
	5	Lifting height	mm	3000	
	6	Free lifting height	mm	0	
	7	Fork size	L×W×T	mm	920×100×35
	8	Tilting angle	F/R ($\alpha^\circ / \beta^\circ$)	Deg	3°/6°
Dimension	9	Overall Dimension	Length(to forkface)	mm	1897
	10		Width	mm	1070
	11		Height when mast lowered	mm	1975
	12		Height when mast extended (with backrest)	mm	4010
	13		Height to safeguard	mm	1971
	14	Turning radius	mm	1544	
	15	Front overhang	mm	371	
	16/17	Tread	F/R	mm	930/0
	18	Ground clearance Min.		mm	85
	19	Wheelbase		mm	1250
	20	Fork spread	Min/Max	mm	200/890
21	Working aisle width with pallet(Ast)*	1000×1200 crossways	mm	3245	
22		800×1200 lengthways	mm	3370	
Performance	23	Speed	Travel(Laden)	km/h	12
	24		Travel(Unladen)	km/h	13
	25		Lifting(Laden)	km/h	280
	26		Lifting(Unladen)	km/h	440
	27	Gradeability	Laden	%	10
	28		Unladen	%	10
	29	Self weight	Include battery box	kg	3240
	30	Tyre	Front×2		18×7-8
31	Rear×1			18×7-8	
Driven	32	Motor	Driven motor	kw	4.5
	33		Pump motor	kw	11
	34	Battery	Standard(option)	V/Ah	48/400
	35	Operating pressure for attachment		Mpa	14.5

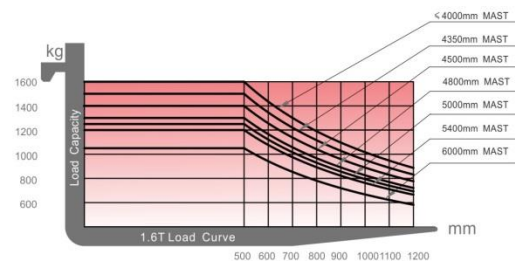
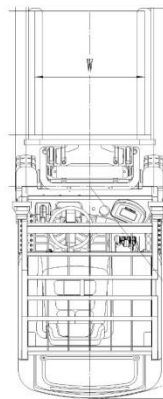
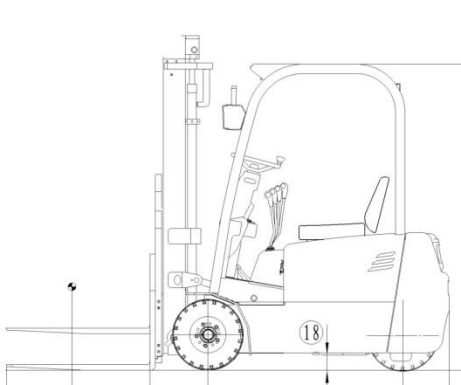

All rights reserved.
Any doubt, please contact us.
Website www.maxforklift.com