

FBA15/18/20/25/30/35-JZ

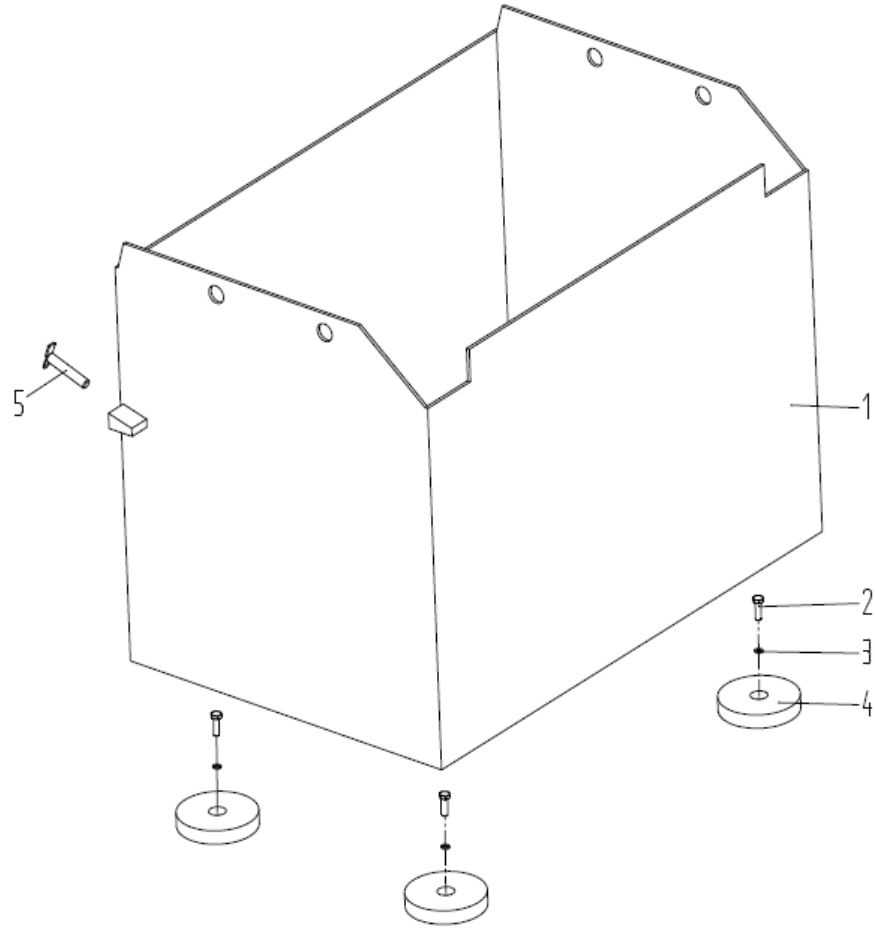

序号	物料号	代号	名称	数量	备注
Item No.	ID.	Part No.	Description	Q'ty	Remark
A	N/A	-	Battery and installation	1	
1	69064539	A30714-01000	Battery	1	FBA30/35-JZ
-	69064791	A25714-01000	Battery	1	FBA20/25-JZ
-	69064579	A15714-01000	Battery	1	FBA15/18-JZ
2	69000125	GB/T5783-M10*25-8.8J	Bolt 10×25	4	
3	69000250	GB/T97.1-10	Washer 10	4	
4	69001584	M2571400002	The battery block	4	
5	69072986	S15714-01000	Pin	1	

图2/Fig. 2 行走电机及传动系统/ TRAVEL MOTOR AND TRANSMISSION SYSTEM

FBA15/18/20/25/30-JZ

序号	物料号	代号	名称	数量	备注
Item No.	ID.	Part No.	Description	Q'ty	Remark

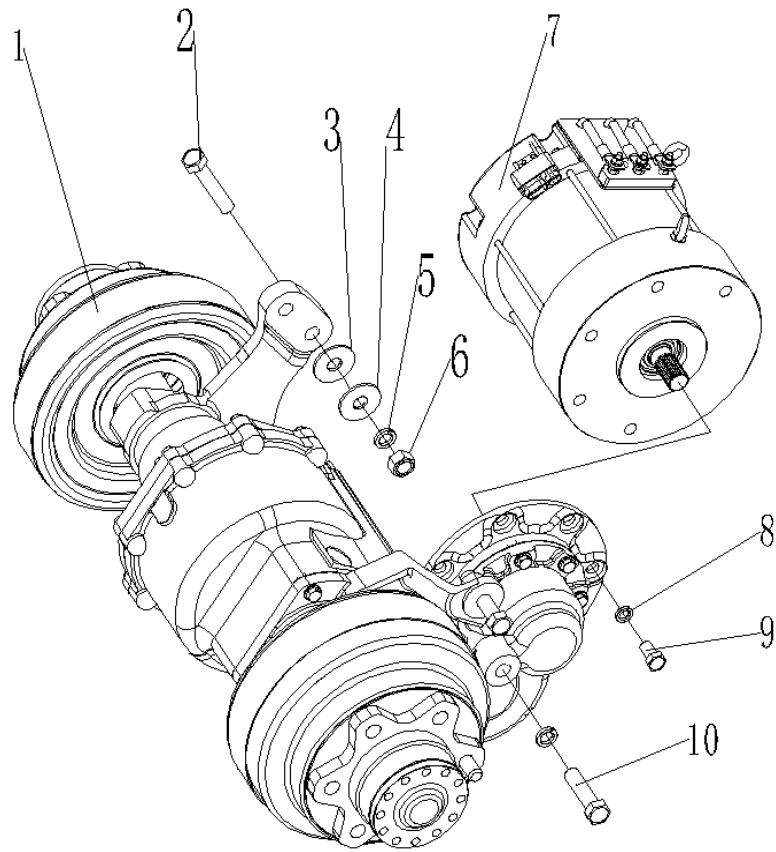

A	N/A	-	Transmission system	1	
1	69079421	A35715-01000	Bridge box	1	FBA35-JZ 2019.01.26以前
-	69062547	A15715-01000	Bridge box	1	FBA15/18-JZ
-	69062546	A25715-01000	Bridge box	1	FBA20/25/30-JZ
2	69093573	GB/T5782-M20*110-12.9J	Bolt M20×110	5	
3	69067158	A25715-00001-0.5mm	Adjusting shim set-0.5mm	按需	
-	69093360	A25715-00001-1.0mm	Adjusting shim set-1.0mm	按需	
-	69093361	A25715-00001-2.0mm	Adjusting shim set-2.0mm	按需	
-	69093362	A25715-00001-3.0mm	Adjusting shim set-3.0mm	按需	
4	69084639	GB/T1230-20	Washer 20	8	
5	69000057	GB/T93-20	Washer 20	8	
6	69000108	GB/T6170-M20-8J	Nut M20	5	
7	69062744	A15715-02000	Travel motor	1	FBA15/18-JZ
-	69062746	A25715-02000	Travel motor	1	FBA20/25-JZ
-	69062748	A30715-01000	Travel motor	1	FBA30-JZ
8	69000056	GB/T93-16	Washer 16	5	
9	69088164	GB/T5783-M16*40-12.9J	Bolt M16×40	5	
10	69093315	GB/T5785-M20*1.5*80-12.9J	Bolt M20×1.5×80	3	

图2/Fig. 2

行走电机及传动系统/ TRAVEL MOTOR AND TRANSMISSION SYSTEM

FBA35-JZ

序号 Item No.	物料号 ID.	代号 Part No.	名称 Description	数量 Q'ty	备注 Remark
A	N/A	-	Transmission system	1	2019.01.26以后
1	69079421	A35715-01000	Bridge box	1	
2	69106288	GB/T5782-M24*110-10.9J	Bolt M24×110	2	

1

9

7

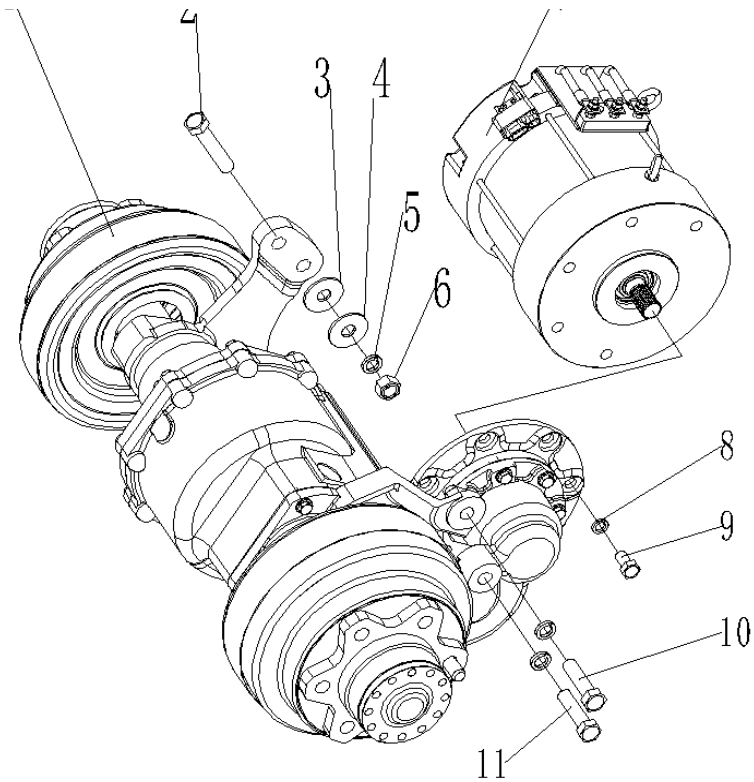

3	69067158	A25715-00001-0.5mm	Adjusting shim set-0.5mm	按需	
-	69093360	A25715-00001-1.0mm	Adjusting shim set-1.0mm	按需	
-	69093361	A25715-00001-2.0mm	Adjusting shim set-2.0mm	按需	
-	69093362	A25715-00001-3.0mm	Adjusting shim set-3.0mm	按需	
4	69006630	GB/T1230-24	Washer 24	8	
5	69006632	GB/T93-24	Washer 24	8	
6	69018337	GB/T6170-M24-8J	Nut M24	5	
7	69062748	A30715-01000	Travel motor	1	
8	69000056	GB/T93-16	Washer 16	5	
9	69088164	GB/T5783-M16*40-12.9J	Bolt M16×40	5	
10	69106287	GB/T27-M24*110-10.9J	Bolt M24×110	3	
11	69106290	GB/T5785-M24*2*80-10.9J	Bolt M24×2×80	3	

图3/Fig. 3 桥箱(中南)/ DRIVE AXLE

FBA15/18/-JZ

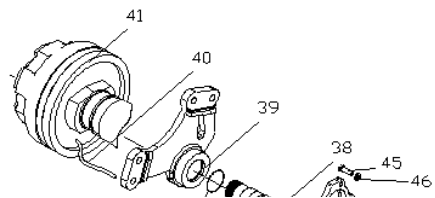

序号	物料号	代号	名称	数量	备注
Item No.	ID.	Part No.	Description	Q'ty	Remark
A	69062547	A15715-01000	Bridge box	1	
1	69136292	GB/T276-1994-01	Bearing	2	
2	69136303	GB/T276-1994-02	Bearing	1	
3	69136269	HQX15.011	Paper pad	1	
4	69093807	HQX15.007	Input shaft	1	
5	69089036	CQT15.901	Left brake	1	

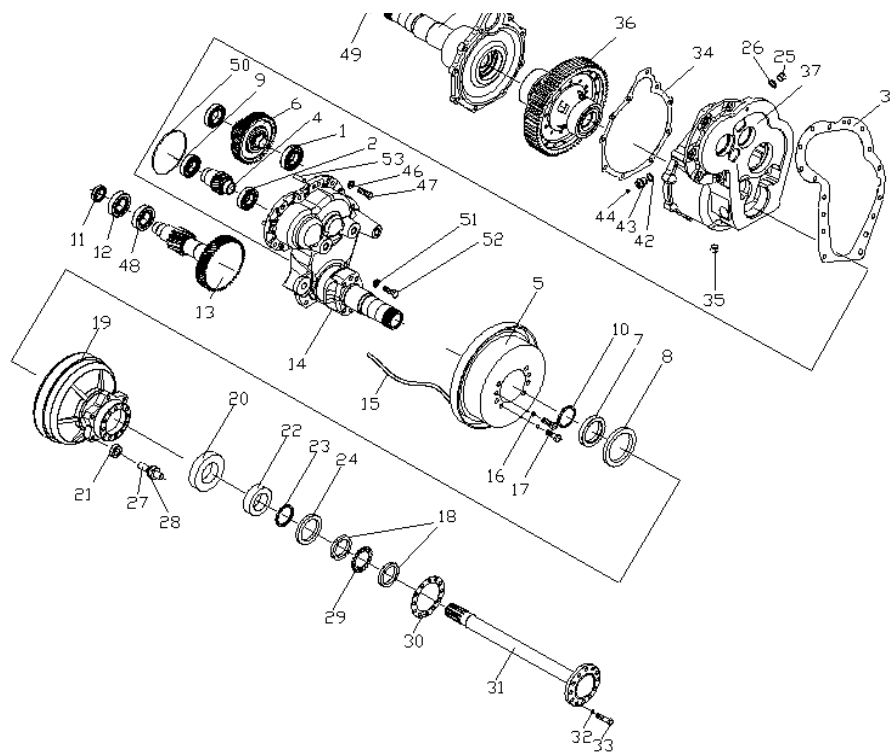

6	69093808	HQX15.902	Gear combination	1	
7	69093809	CQT15.007	Seal ring	2	
8	69136499	GB/T 9877.1-1988-FB100*130*12	Oil seal ring	2	
9	69136270	GB/T276-1994-03	Bearing	1	
10	69136510	GB/T 3452.1-2005-67.0*2.65G	O-Ring	2	
11	69093810	YDS30.024	Nut	1	
12	69136302	GB/T297-1994-04	Bearing	1	
13	69093811	HQX15 II.903	Gear combination	1	
14	69136509	HQX15 II.801	Left box	1	
15	69092712	CQT15.903	Left brake cable	1	
16	69005111	GB/T93-14	Washer	12	
17	69136501	GB/T 5786-2000-	Bolt	12	
18	69136502	GB/T 810-1988	Nut	4	
19	69136511	HQX15 II.007	Brake drum	2	
20	69030548	LS30548	Bearing	2	
21	69000315	GB/T6171-M12*1.5-8J	Nut	12	
22	69136277	GB/T297-1994-02	Bearing	2	

图3/Fig. 3 桥箱(中南)/ DRIVE AXLE

FBA15/18/-JZ

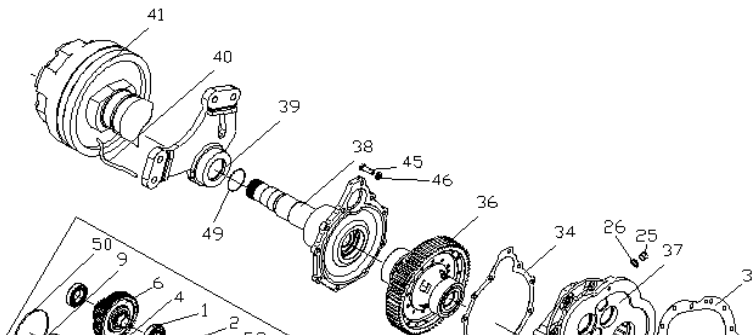

序号	物料号	代号	名称	数量	备注
Item No.	ID.	Part No.	Description	Q'ty	Remark
23	69093814	CQT15.006	Oil seal seat	2	
24	69136503	GB/T 9877.1-1988-FB70*95*10	Oil seal ring	2	
25	69136504	JB/T 1001-1977	Plug	1	
26	69136283	JB/T 982-1977	Washer	1	
27	69136512	HQX15 II.010	Bolt	12	
28	69136513	QC/T 354-1999	Nut	12	
29	69021322	GB/T858-1988-60	Washer	2	
30	69136514	HQX15 II.011	Paper cushion	2	
31	69136515	HQX15 II.008	Half axle	2	

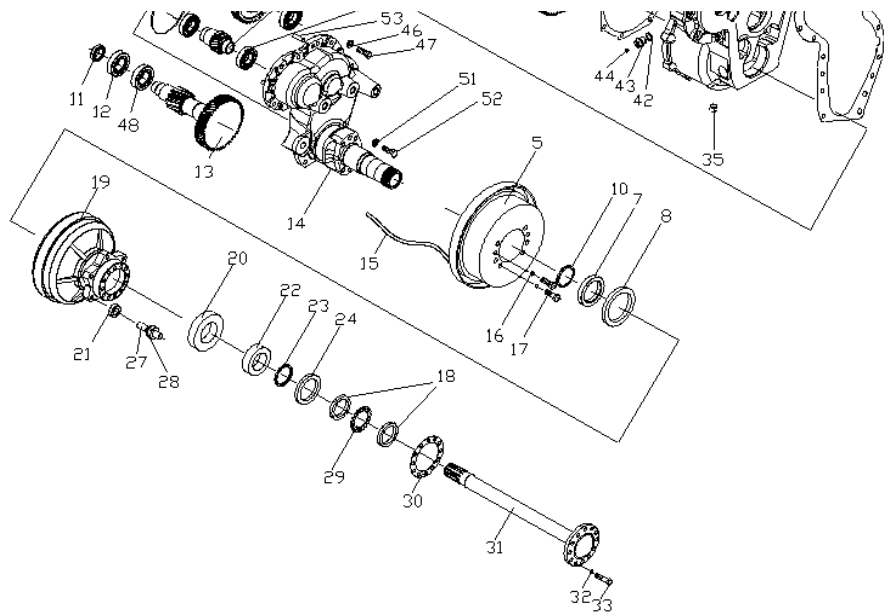

32	69000053	GB/T93-10	Washer	24	
33	69136505	GB/T 5786-2000-M10*1.25*45-10.9J	Bolt	24	
34	69136318	HQX15.012	Paper pad	1	
35	69093815	YDS30.104	Plug	1	
36	69136284	HQX25.901	Differential ass'y	1	
37	69136516	HQX15 II.001	Intermediate case	1	
38	69136517	HQX15 II.802	Right box cover	1	
39	69136518	HQX15 II.004	Right support plate	1	
40	69092713	CQT15.904	Right brake dragline	1	
41	69089037	CQT15.902	Right brake	1	
42	69000357	JB/T982-20	Washer	1	
43	69093819	CQT15.003	Ventilation plug	1	
44	69136289	QC/T 410-1999	Breather plug	1	
45	69137301	GB/T 5786-2000-M12×1.5×40	Bolt	10	

图3/Fig. 3 桥箱(中南)/ DRIVE AXLE

FBA15/18/-JZ

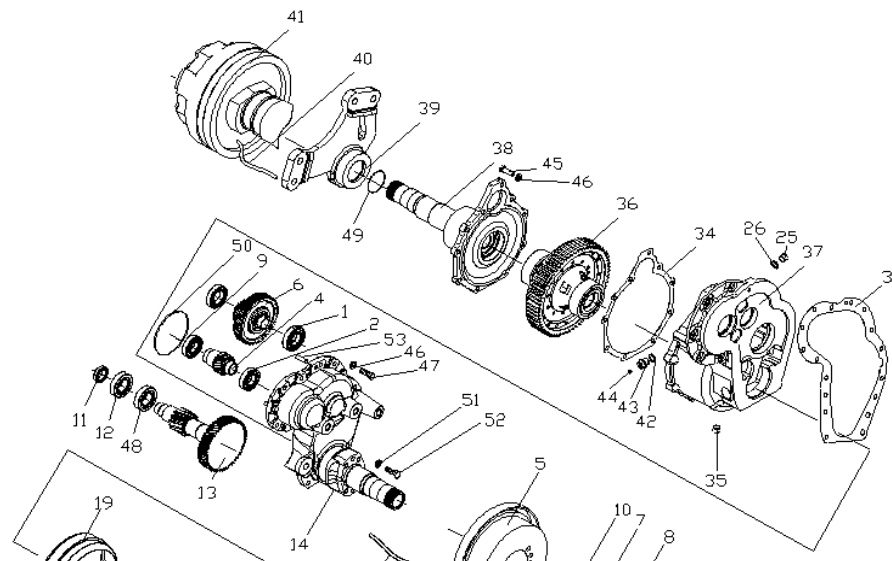

序号	物料号	代号	名称	数量	备注
Item No.	ID.	Part No.	Description	Q'ty	Remark
46	69000054	GB/T93-12	Washer	25	
47	69137302	GB/T 5786-2000-M12×1.5×35	Bolt	15	
48	69137303	GB/T 297-1994-32915	Bearing	1	
49	69135140	80×3.1 GB1235-76	O-Ring	2	
50	69136507	GB1235-76-145*3.1	O-Ring	1	
51	69000056	GB/T93-16	Washer	2	
52	69000165	GB/T5786-M16*1.5*45-8.8J	Bolt	2	
53	69136520	GB/T 119.1-10h8×30	Cylindrical pin	1	





图3/Fig. 3

桥箱(中南)/ DRIVE AXLE

FBA20/25/30-JZ

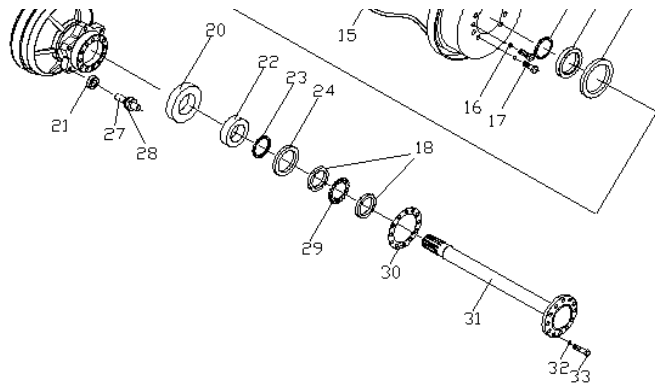
序号	物料号	代号	名称	数量	备注
Item No.	ID.	Part No.	Description	Q'ty	Remark
B	69062546	A25715-01000	Bridge box	1	
1	69136292	GB/T276-1994-01	Bearing	2	
2	69136303	GB/T276-1994-02	Bearing	1	
3	69136269	HQX15. 011	Paper pad	1	
4	69093807	HQX15. 007	Input shaft	1	
5	69095283	CQT20. 901	Left brake	1	
6	69093808	HQX15. 902	Gear combination	1	
7	69085803	CQT20. 006	Seal ring	2	
8	69136499	GB/T 9877. 1-1988-FB100*130*12	Oil seal ring	2	
9	69008354	LS8354	Bearing	1	
10	69136500	GB/T 3452. 1-2005	O-Ring	2	
11	69093810	YDS30. 024	Nut	1	
12	69028537	LS28537	Bearing	1	
13	69136316	HQX15. 903	Gear combination	1	
14	69136286	HQX25. 801	Left box	1	

15	69136309	CQT30C.903	Left brake cable	1	
16	69005111	GB/T93-14	Washer	16	
17	69136501	GB/T 5786-2000-	Bolt	16	
18	69136502	GB/T 810-1988	Nut	4	
19	69095285	HQX25.007	Brake drum	2	
20	69024928	LS24928	Bearing	2	
21	69085804	HQX25.008		2	
22	69136266	GB/T297-1994-08	Bearing	2	

图3/Fig. 3

桥箱(中南)/ DRIVE AXLE

FBA20/25/30-JZ

序号	物料号	代号	名称	数量	备注
Item No.	ID.	Part No.	Description	Q'ty	Remark
23	69085805	CQT25.003	Oil seal seat	2	
24	69136285	GB/T 9877.1-1988-01	Oil seal ring	2	
25	69136315	JB/T 1001-1977-M18*1.5	Plug	1	
26	69136283	JB/T 982-1977	Washer	1	
27	69085806	HQX25.011	Bolt	20	
28	69136287	QC/T 354-1999-M18*1.5	Nut	20	
29	69021322	GB/T858-1988-60	Washer	2	
30	69085807	HQX25.010	Paper cushion	2	
31	69136282	HQX25.009	Half axle	2	
32	69000053	GB/T93-10	Washer	20	
33	69136505	GB/T 5786-2000-M10*1.25*45-10.9J	Bolt	20	
34	69136318	HQX15.012	Paper cushion	1	
35	69093815	YDS30.104	Plug	1	
36	69136284	HQX25.901	Differential ass'y	1	
37	69136275	HQX15.001	Intermediate case	1	
38	69093817	HQX25.802	Right box cover	1	
39	69136314	HQX25.004	Right support plate	1	
40	69092715	CQT20.904	Right brake dragline	1	

41	69095284	CQT20.902	Right brake	1	
42	69000357	JB/T982-20	Washer	1	
43	69093819	CQT15.003	Washer	1	
44	69136289	QC/T 410-1999	Breather plug	1	
45	69137301	GB/T 5786-2000-M12×1.5×40	Bolt	10	
<b>序号</b>	<b>物料号</b>	<b>代号</b>	<b>名称</b>	<b>数量</b>	<b>备注</b>
<b>Item No.</b>	<b>ID.</b>	<b>Part No.</b>	<b>Description</b>	<b>Q'ty</b>	<b>Remark</b>
46	69000054	GB/T93-12	Washer	25	
47	69137302	GB/T 5786-2000-M12×1.5×35	Bolt	15	
48	69137303	GB/T 297-1994-32915	Bearing	1	
49	69136506	GB1235-76-90*3.1	O-Ring	2	
50	69136507	GB1235-76-145*3.1	O-Ring	1	
51	69000056	GB/T93-16	Washer	2	
52	69000165	GB/T5786-M16*1.5*45-8.8J	Bolt	2	
53	69136520	GB/T 119.1-10h8×30	Cylindrical pin	1	

FBA20/25/30-JZ



FBA35-JZ

序号	物料号	代号	名称	数量	备注
Item No.	ID.	Part No.	Description	Q' ty	Remark
C	69106240	A35715-01000A	Bridge box	1	
1	69136292	GB/T276-1994-01	Bearing	2	
2	69136303	GB/T276-1994-02	Bearing	1	
3	69136269	HQX15.011	Paper pad	1	
4	69093807	HQX15.007	Input shaft	1	
5	69136291	CQT30.901	Left brake	1	
6	69093808	HQX15.902	Gear combination	1	
7	69085803	CQT20.006	Gear combination	2	
8	69136499	GB/T 9877.1-1988-FB100*130*12	Oil seal ring	2	
9	69008354	GB/T276-6009	Bearing	1	
10	69136500	GB/T 3452.1-2005	O-Ring	2	
11	69093810	YDS30.024	Nut	1	
12	69028537	LS28537	Bearing	1	
13	69136316	HQX15.903	Gear combination	1	
14	69136521	HQX35.801G1	Left box	1	
15	69136309	CQT30C.903	Left brake cable	1	
16	69005111	GB/T93-14	Washer	16	
17	69136501	GB/T 5786-2000-	Bolt	12	
-	69136522	CQT30.010	Bolt	4	
18	69136502	GB/T 810-1988	Nut	4	
19	69121833	HQX35.007	Brake drum	2	
20	69024928	LS24928	Bearing	2	
21	69136326	HQX35.008	Hub	2	
序号	物料号	代号	名称	数量	备注
Item No.	ID.	Part No.	Description	Q' ty	Remark
22	69136266	GB/T297-1994-08	Bearing	2	

FBA35-JZ

23	69121834	CQT30.006	Oil seal seat	2	
24	69137304	GB/T 9877.1-1988-FB75×100×10	Oil seal ring	2	
25	69136315	JB/T 1001-1977-M18*1.5	Plug	1	
26	69136283	JB/T 982-1977	Washer	1	
27	69085806	HQX25.011	Bolt	24	
28	69136287	QC/T 354-1999-M18*1.5	Nut	24	
29	69021322	GB/T858-1988-60	Washer	2	
30	69136324	CQT30.003	Paper cushion	2	
31	69136317	HQX35.009	Half axle	2	
32	69000054	GB/T93-12	Washer	49	
33	69137301	GB/T 5786-2000-M12×1.5×40	Bolt	24	
34	69136318	HQX15.012	Paper cushion	1	
35	69093815	YDS30.104	Plug	1	
36	69136284	HQX25.901	Differential ass'y	1	
37	69136275	HQX15.001	Intermediate case	1	
38	69136320	HQX35.802	Right box cover	1	
39	69136307	HQX35.004	Right support plate	1	
40	69093818	CQT30.904	Right brake dragline	1	
41	69136293	CQT30.902	Right brake	1	
42	69000357	JB/T982-20	Washer	1	
43	69093819	CQT15.003	Ventilation plug	1	
44	69136289	QC/T 410-1999	Breather plug	1	

FBA35-JZ

序号	物料号	代号	名称	数量	备注
Item No.	ID.	Part No.	Description	Q'ty	Remark
45	69137301	GB/T 5786-2000-M12×1.5×40	Bolt	10	
46	69137302	GB/T 5786-2000-M12×1.5×35	Bolt	15	
47	69137303	GB/T 297-1994-32915	Bearing	1	
48	69136506	GB1235-76-90*3.1	O-Ring	2	
49	69136507	GB1235-76-145*3.1	O-Ring	1	

50	69000056	GB/T93-16	Washer	2	
51	69000165	GB/T5786-M16*1.5*45-8.8J	Bolt	2	
52	69136520	GB/T 119.1-10h8×30	Cylindrical pin	1	

图3/Fig. 3 桥箱(华鹰HYMX1531000)/ DRIVE AXLE

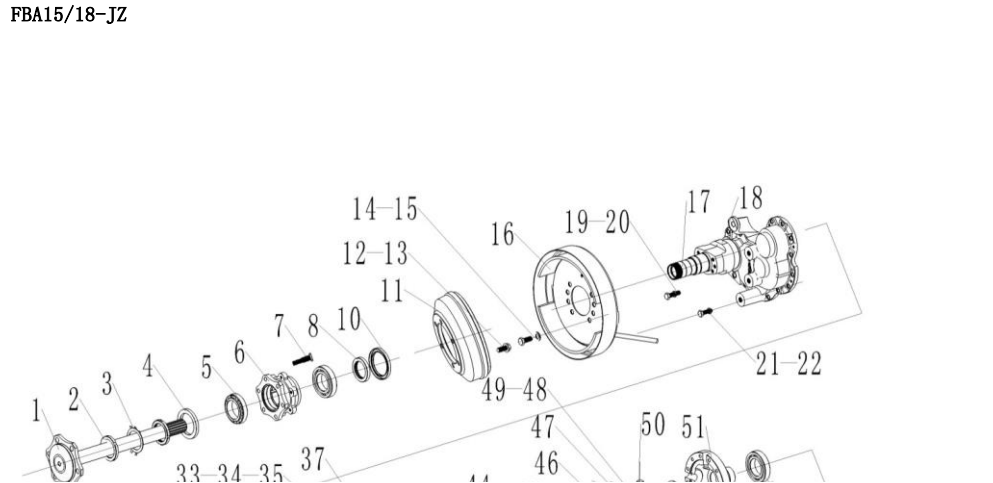

序号	物料号	代号	名称	数量	备注
Item No.	ID.	Part No.	Description	Q'ty	Remark
1	69139468	HYMX1531301	Half axle	2	
2	69139469	GB/T810-M65*2	Nut M65×2	4	
3	69136304	GB/858-1988	Washer 65	2	
4	69136323	GB/T13871-2007-01	Oil seal TC42×55×9	2	
5	69136389	GB/T297-1994-05	Bearing32013	4	
6	69139470	HYMX1531551	Hub	2	
7	69139471	HYMX1531550	Bolt	12	
8	69139472	GB/T13871-TC74*98*12	Oil seal TC74×98×12	2	

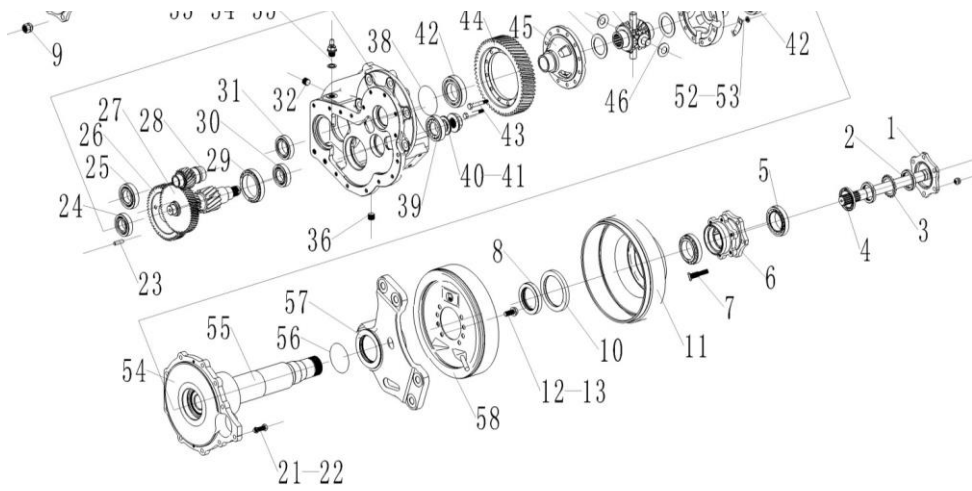

9	69074490	QC/T354-M14*1.5-10J	Nut M14×1.5	12	
10	69139473	HYJH1531520	Oil seal holder	2	
11	69139474	HVMX1531531	Brake drum	2	
12	69006936	GB/T5783-M14*40-8.8J	Bolt M14×40	12	
13	69005111	GB/T93-14	Washer 14	12	
14	69033319	GB/T5786-M14*1.5*35-8.8J	Bolt M14×1.5×35	12	
15	69000252	GB/T97.1-14	Washer 14	12	
16	69139475	HVMX1531474	The left brake ass'y	1	
17	69139476	HVMX1531370	Casing, left axle	1	
18	69139477	HVMX1531350	Box 2	1	
19	69000170	GB/T5783-M16*45-8.8J	Bolt M16×45	2	
20	69000056	GB/T93-16	Washer 16	2	
21	69000155	GB/T5783-M12*40-8.8J	Bolt M12×40	25	
22	69000054	GB/T93-12	Washer 12	25	
23	69136278	14200-19480	Positioning pin	1	

图3/Fig. 3

桥箱(华鹰HVMX1531000)/ DRIVE AXLE

FBA15/18-JZ

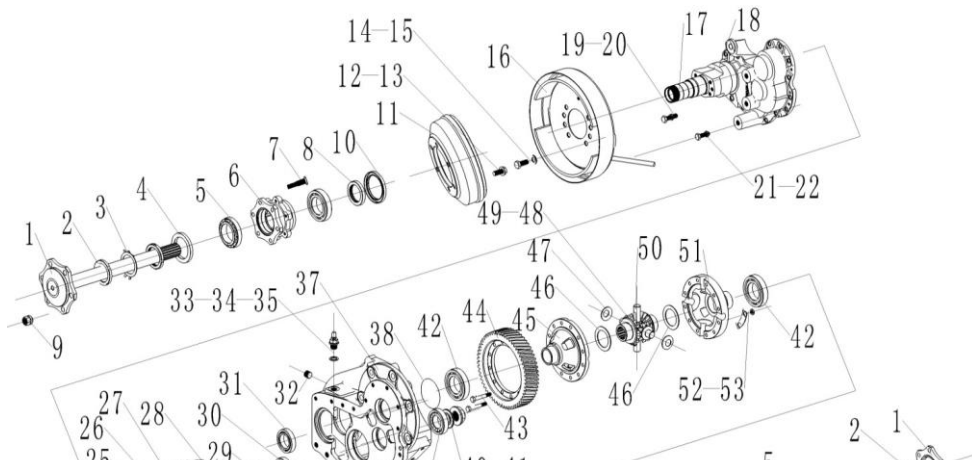

序号	物料号	代号	名称	数量	备注
Item No.	ID.	Part No.	Description	Q'ty	Remark
24	69136292	GB/T276-1994-01	Bearing 6207	1	
25	69136303	GB/T276-1994-02	Bearing 6208	1	
26	69136300	HVMX2531180	Gear 2	1	
27	69139478	HVMX1531190	Gear 3	1	
28	69136308	HVMX2531170	Gear 1	1	
29	69139479	GB/T297-32915X	Tapered roller bearing 32915X	1	
30	69136268	GB/T276-1994-04	Ball bearing 62/32	1	
31	69136270	GB/T276-1994-03	Ball bearing 6009	1	
32	69136280	0006-6004	Hexagon head choke plug	1	
33	69136276	HVMX2531471	Breather plug	1	
34	69136306	QC/T412	Valve Z1/8	1	

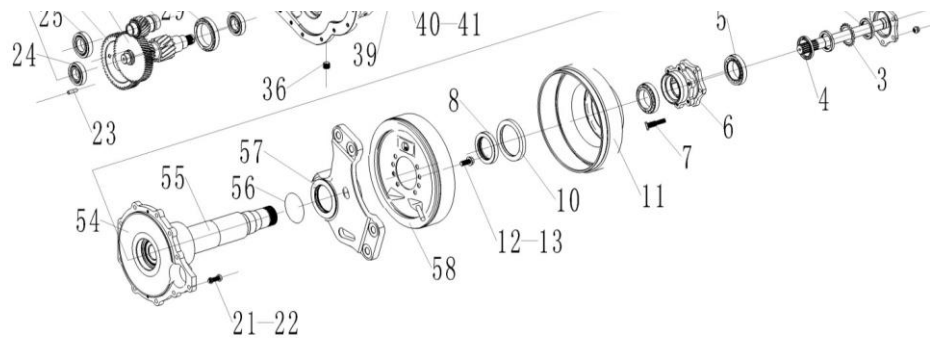

35	69136212	JB982-1977	Washer 20	1	
36	69136288	0006-6004A	Hexagon head choke plug	1	
37	69139480	HYMX1531470	Box 1	1	
38	69136507	GB1235-76-145*3.1	O-ring 145×3.1	1	
39	69136302	GB/T297-1994-04	Tapered roller bearing 32208	1	
40	69136301	14200-30015	Nut	1	
41	69136325	14200-13290-0	Washer	1	
42	69136265	GB/T276-1994-05	Ball bearing 6211	2	
43	69136272	HYMX2531216	Bolt	12	
44	69136319	HYMX2531200	Gear 4	1	
45	69136274	HYMX2531219-1	Left differential case	1	
46	69136294	HYMX2531214	Flat shim	2	

图3/ Fig. 3 桥箱(华鹰HYMX1531000)/ DRIVE AXLE

FBA15/18-JZ

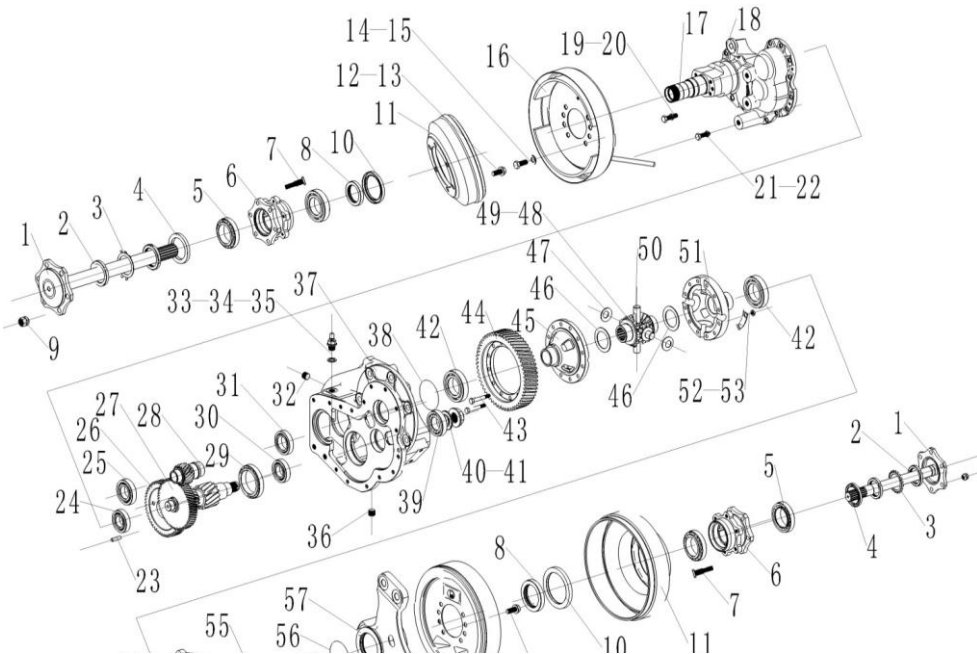

序号	物料号	代号	名称	数量	备注
Item No.	ID.	Part No.	Description	Q'ty	Remark
47	69136267	HYMX2531213	Ball shim	4	
48	69136313	HYMX2531211	Planetary bevel gear	4	
49	69136339	HYMX2531212	Shaft bevel gear	2	
50	69136331	HYMX2531215	Cross planetary axis	1	
51	69136342	HYMX2531219-2	Right differential case	1	
52	69136271	HYMX2531217	Locking plate 1	6	
53	69033312	GB/T41-M10	Nut M10	12	
54	69139481	HYMX1531420	Box 3	1	
55	69139482	HYMX1531430	The right axle casing	1	
56	69139483	GB/T3452.1-75*2.65	O-ring 75×2.65	2	
57	69139484	HYMX1531501	The right holder	1	
58	69139485	HYMX1531475	The right brake ass'y	1	





图3/Fig. 3 桥箱(华鹰HYMX2531000)/ DRIVE AXLE

FBA20/25/30-JZ

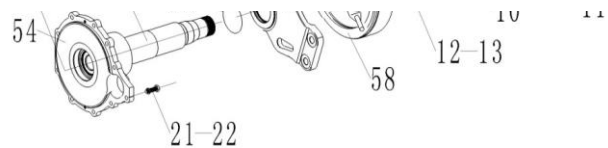
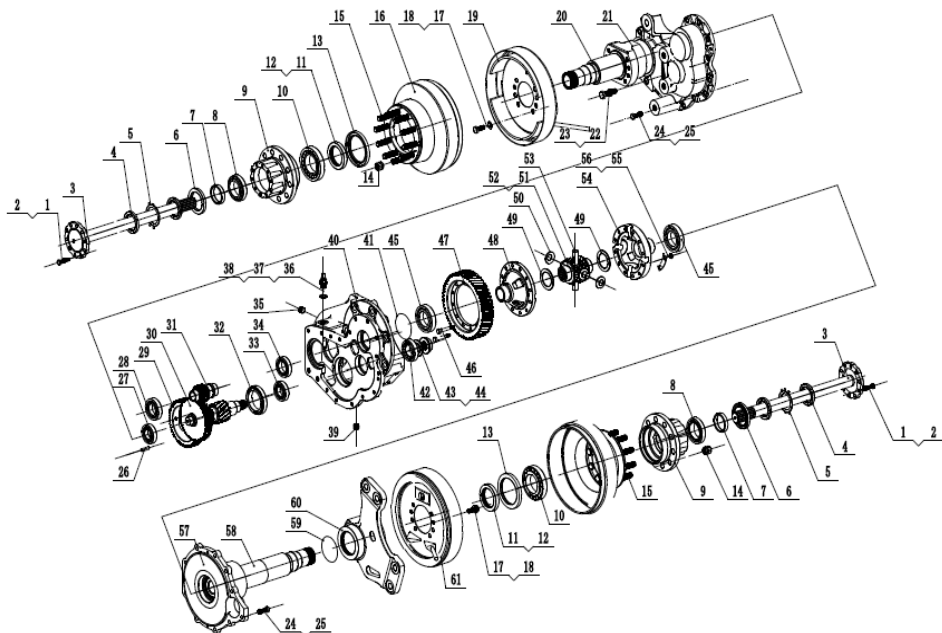

序号 Item No.	物料号 ID.	代号 Part No.	名称 Description	数量 Q'ty	备注 Remark
1	69092287	GB/T5783-M10*45-10.9J	Bolt M10×45	20	
2	69000053	GB/T93-10	Washer 10	20	
3	69136426	HYMX2531301	Half axle	2	
4	69138560	GB/T810-M60*2	Nut M60×2	4	
5	69021322	GB/T858-1988-60	Washer 60	2	
6	69136416	GB/T13871-2007-05	Oil seal TC70×95×10	2	
7	69138561	HYMX2531580	Bushing	2	
8	69136277	GB/T297-1994-02	Tapered roller bearing 32012	2	
9	69136470	HYMX2531551	Hub	2	
10	69080813	GB/T297-30214	Tapered roller bearing 30214	2	
11	69138562	HYMX2531570	Oil seal set	2	
12	69136443	GB/T1235-1976	O-ring 78×3.5	2	
13	69136456	GB/T13871-2007-04	Oil seal TC100×130×12	2	
14	69063479	QC/T354-M18*1.5-8J	Nut M18×1.5	20	
15	69136365	HYMX2531550	Bolt	20	
16	69136420	HYMX2531531	Brake drum	2	
17	69136355	0012-14040	Hexagon bolt	16	

18	69136381	0000-72014	Washer 14	16	
19	69136423	HYMX2531474	The left brake	1	
20	69136471	HYMX2531370	The left axle tube	1	
21	69136418	HYMX2531350	Box 2	1	
22	69000170	GB/T5783-M16*45-8.8J	Bolt M16×45	2	
23	69000056	GB/T93-16	Washer 16	2	

图3/Fig. 3 桥箱(华鹰HYMX2531000)/ DRIVE AXLE

FBA20/25/30-JZ

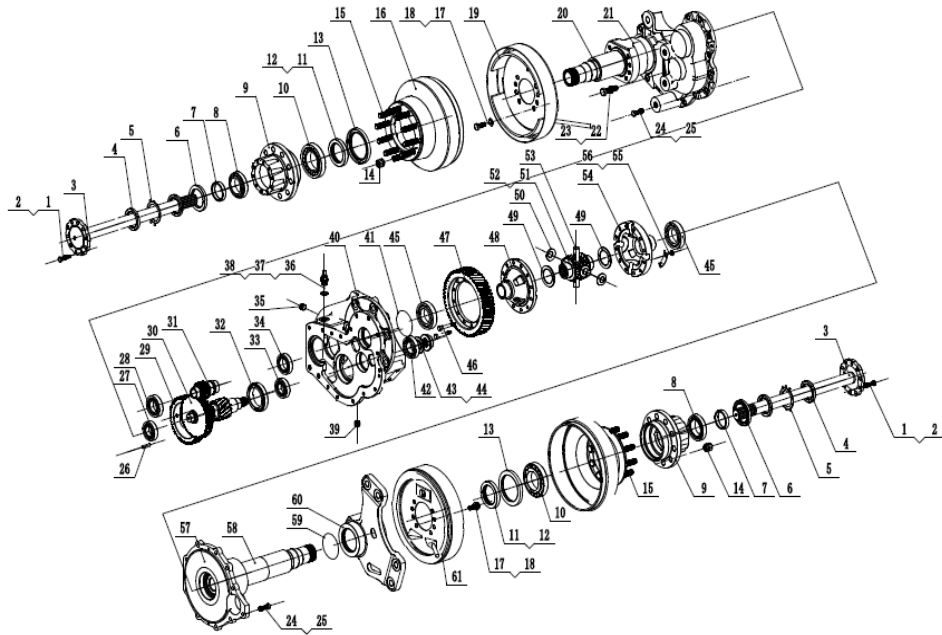

序号	物料号	代号	名称	数量	备注
Item No.	ID.	Part No.	Description	Q'ty	Remark
24	69000155	GB/T5783-M12*40-8.8J	Bolt M12×40	25	
25	69000054	GB/T93-12	Washer 12	25	
26	69136278	14200-19480	Positioning pin	1	
27	69136292	GB/T276-1994-01	Ball bearing 6207	2	
28	69136303	GB/T276-1994-02	Ball bearing 6208	1	
29	69136379	HYMX2531190	Gear 3	1	
30	69136300	HYMX2531180	Gear 2	1	
31	69136308	HYMX2531170	Gear 1	1	
32	69139479	GB/T297-32915X	Tapered roller bearing 32915X	1	
33	69136268	GB/T276-1994-04	Ball bearing 62/32	1	
34	69136270	GB/T276-1994-03	Bearing 6009	1	
35	69136280	0006-6004	Hexagon head choke plug	1	
36	69136276	HYMX2531471	Breather plug	1	
37	69136306	QC/T412	Valve Z1/8	1	
38	69136212	JB982-1977	Washer	1	
39	69136288	0006-6004A	Hexagon head choke plug	1	
40	69136279	HYMX2531470	Box 1	1	
41	69136302	GB/T297-1994-04	Tapered roller bearing 32208	1	
42	69136301	14200-30015	Nut	1	
43	69136325	14200-13290-0	Washer	1	





图3/Fig. 3

## 桥箱(华鹰HYMX3531000)/ DRIVE AXLE

FBA35-JZ

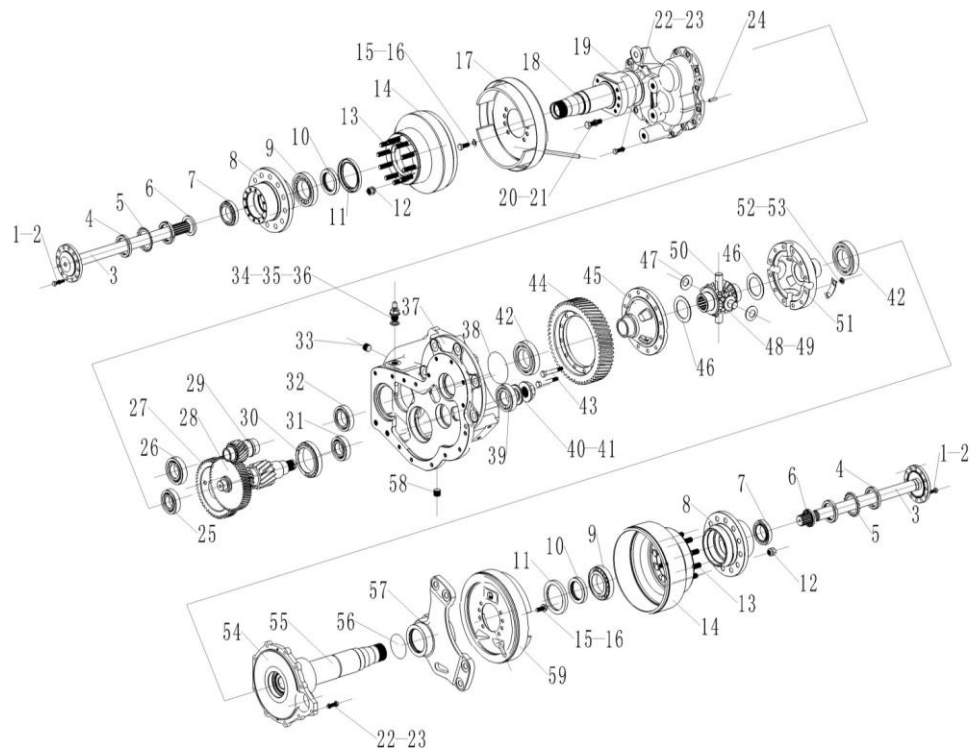

序号	物料号	代号	名称	数量	备注
Item No.	ID.	Part No.	Description	Q' ty	Remark
1	69092287	GB/T5783-M10*45-10.9J	Bolt M10×45	24	
2	69000053	GB/T93-10	Washer 10	24	
3	69136366	HYMX3531301	Half axle	2	
4	69139469	GB/T810-M65*2	Nut M65×2	4	
5	69136304	GB/858-1988	Washer 65	2	
6	69136323	GB/T13871-2007-01	Oil seal TC42×55×9	2	
7	69139479	GB/T297-32915X	Tapered roller bearing 32013X	2	
8	69136362	HYMX3531551	Hub	2	
9	69136347	GB/T297-1994-06	Tapered roller bearing 30215	2	
10	69136390	GB/T13871-2007-02	Oil seal TC85×110×12	2	
11	69136348	HYMX3531570	Oil seal seat	2	
12	69063479	QC/T354-M18*1.5-8J	Nut M18×1.5	24	
13	69136365	HYMX2531550	Bolt	24	
14	69136350	HYMX3531531	Brake drum	2	
15	69136355	0012-14040	Bolt	16	
16	69136381	0000-72014	Washer 14	16	
17	69136328	HYMX3531474	The left brake	1	
18	69136364	HYMX3531370	The left axle tube	1	
19	69136344	HYMX3531350	Box 2	1	
20	69000170	GB/T5783-M16*45-8.8J	Bolt M16×45	2	
21	69000056	GB/T93-16	Washer 16	2	
22	69000155	GB/T5783-M12*40-8.8J	Bolt M12×40	25	
23	69000054	GB/T93-12	Washer 12	25	

图3/Fig. 3

## 桥箱(华鹰HYMX3531000)/ DRIVE AXLE

FBA35-JZ

序号	物料号	代号	名称	数量	备注
Item No.	ID.	Part No.	Description	Q' ty	Remark

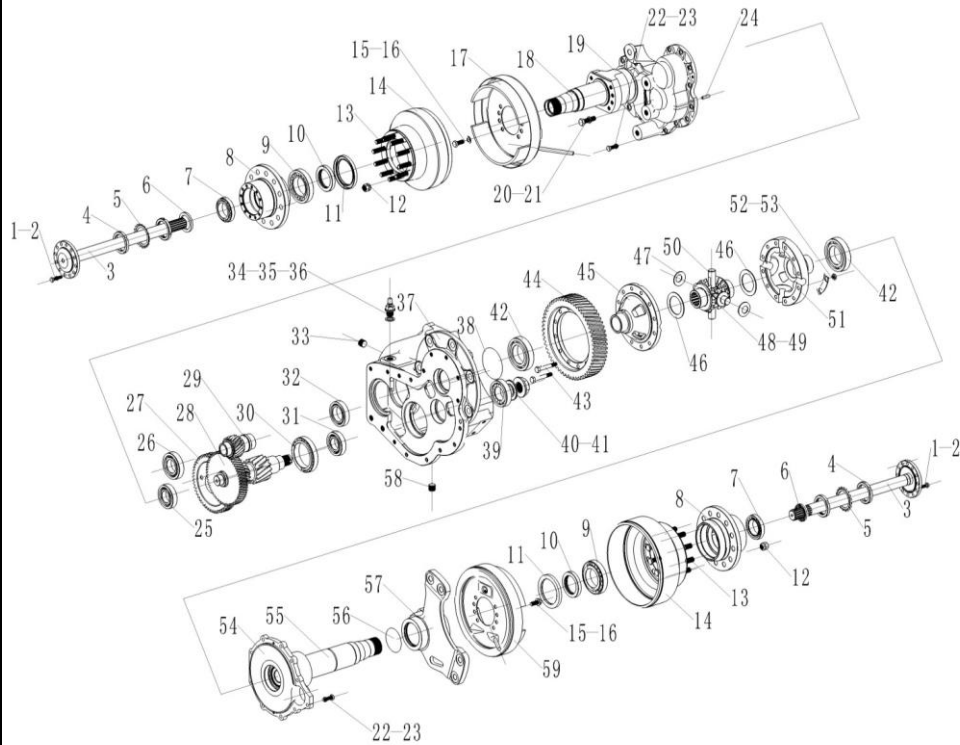

24	69136278	14200-19480	Positioning pin	1	
25	69136292	GB/T276-1994-01	Bearing 6207	1	
26	69136303	GB/T276-1994-02	Bearing 6208	1	
27	69136300	HYMX2531180	Gear 2	1	
28	69136379	HYMX2531190	Gear 3	1	
29	69136308	HYMX2531170	Gear 1	1	
30	69139479	GB/T297-32915X	Tapered roller bearing 32915X	1	
31	69136268	GB/T276-1994-04	Bearing 62/32	1	
32	69136270	GB/T276-1994-03	Bearing 6009	1	
33	69136280	0006-6004	Hexagon head choke plug	1	
34	69136276	HYMX2531471	Breather plug	1	
35	69136306	QC/T412	Valve Z1/8	1	
36	69136212	JB982-1977	Washer	1	
37	69136346	HYMX3531470	Box 1	1	
38	69136507	GB1235-76-145*3.1	O-ring 145×3.1	1	
39	69136302	GB/T297-1994-04	Tapered roller bearing 32208	1	
40	69136301	14200-30015	Nut	1	
41	69136325	14200-13290-0	Washer	1	
42	69136265	GB/T276-1994-05	Ball bearing 6211	2	
43	69136272	HYMX2531216	Bolt	12	
44	69136319	HYMX2531200	Gear 4	1	
45	69136274	HYMX2531219-1	Left differential case	1	
46	69136294	HYMX2531214	Flat shim	2	

图3/Fig. 3

桥箱 (华鹰HYMX3531000) / DRIVE AXLE

FBA35-JZ

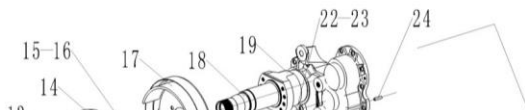

序号	物料号	代号	名称	数量	备注
Item No.	ID.	Part No.	Description	Q'ty	Remark
47	69136267	HYMX2531213	Ball shim	4	
48	69136313	HYMX2531211	Planetary bevel gear	4	
49	69136339	HYMX2531212	Shaft bevel gear	2	

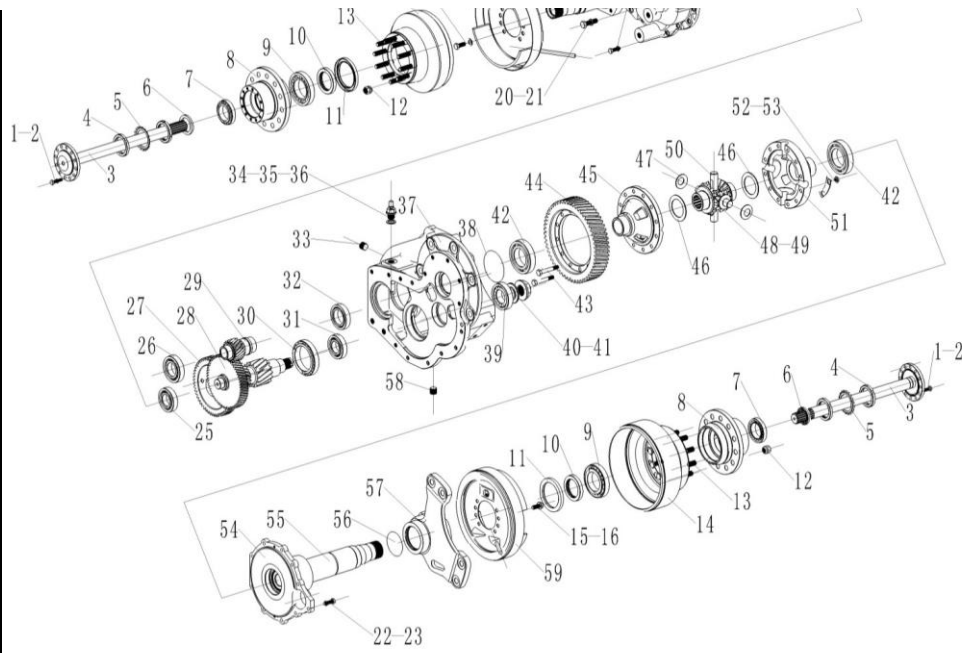

50	69136331	HYMX2531215	Cross planetary axis	1	
51	69136342	HYMX2531219-2	Right differential case	1	
52	69136271	HYMX2531217	Locking plate 1	6	
53	69033312	GB/T41-M10	Nut 10	12	
54	69136396	HYMX3531420	Box 3	1	
55	69136386	HYMX3531430	The right axle casing	1	
56	69138564	GB/T3452.1-90*2.65	O-ring 90×2.65	2	
57	69136341	HYMX3531501	The right holder	1	
58	69136288	0006-6004A	Hexagon head choke plug	1	
59	69136329	HYMX3531475	The right brake ass'y	1	

**图4/ Fig. 4 差速器/ DIFFERENTIAL**

FBA15/18/20/25/30/35-JZ

序号	物料号	代号	名称	数量	备注
Item No.	ID.	Part No.	Description	Q' ty	Remark
1	69016773	GB/T276-6211	Bearing 6211	2	
2	69138565	JDS18.004	Bolt	12	
3	69136527	HQX15.010	Gear ring	1	
4	69136525	YDS25.012	Washer	2	
5	69136526	YDS25.007	Planet gear	2	
6	69136528	YDS25.006	Washer lock	32	

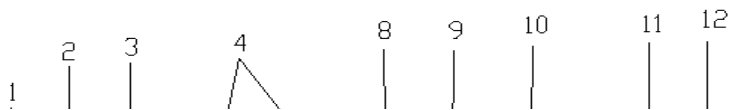

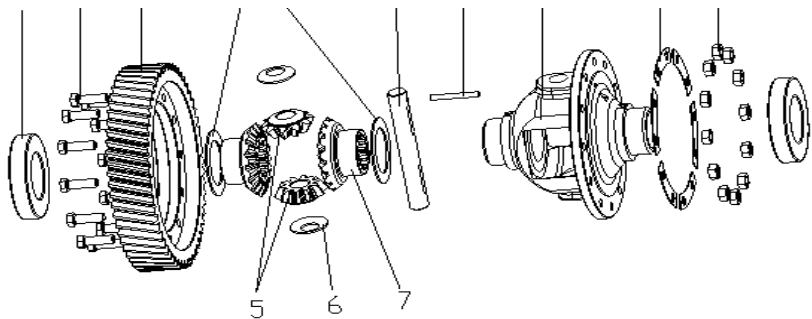

7	69007169	YDS25.011	Half axle gear	2	
8	69138566	JDS18.003	Gear shaft	1	
9	69138567	GB/T 118-A6*60	Pin A6×60	1	
10	69138568	JDS18.001	Differential box	1	
11	69136384	YDS25.014	Space lock	6	
12	69136367	GB/T6176-2000	Nut M10×1.25	12	

图5/Fig. 5 起升电机及安装/ LIFTING MOTOR AND INSTALLATION

FBA15/18/20/25/30/35-JZ

序号 Item No.	物料号 ID.	代号 Part No.	名称 Description	数量 Q'ty	备注 Remark
1	69000130	GB/T5783-M10*35-8.8J	Bolt M10×35	2	
2	69000053	GB/T93-10	Washer 10	2	
3	69000250	GB/T97.1-10	Washer 10	2	
4	69062745	A15718-01000	Lifting motor	1	FBA15/18-JZ
-	69062747	A25718-01000	Lifting motor	1	FBA20/25-JZ
-	69062749	A30718-01000	Lifting motor	1	FBA30/35-JZ
5	69017795	GB/T5783-M8*50-8.8J	Bolt M8×50	4	
6	69000062	GB/T93-8	Washer 8	4	
7	69068879	A25718-00003	Washer	4	

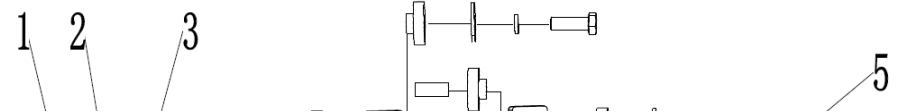

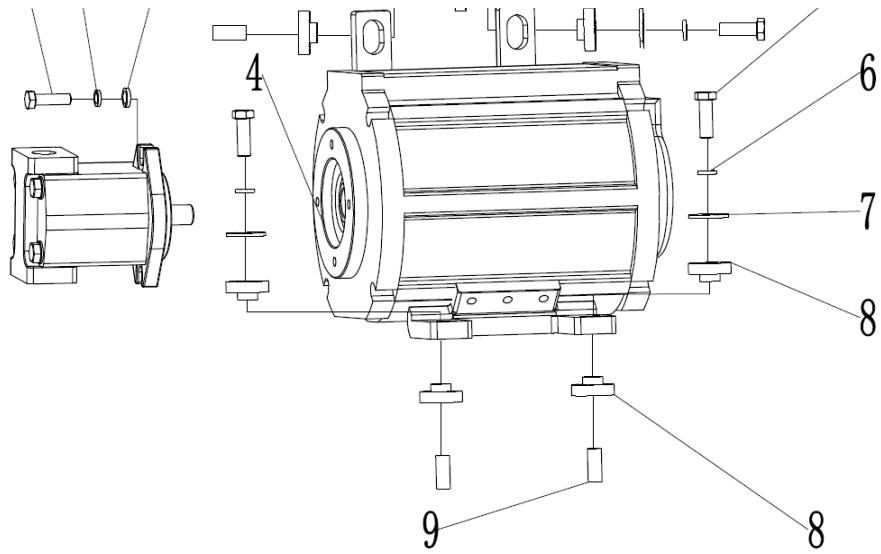

8	69064530	A25718-00001	Damping rubber pad	8	
9	69064529	A25718-00002	Spacer sleeve	4	

图6/Fig. 6 电气系统/ ELECTRICAL SYSTEM

FBA15/18/20/25/30/35-JZ

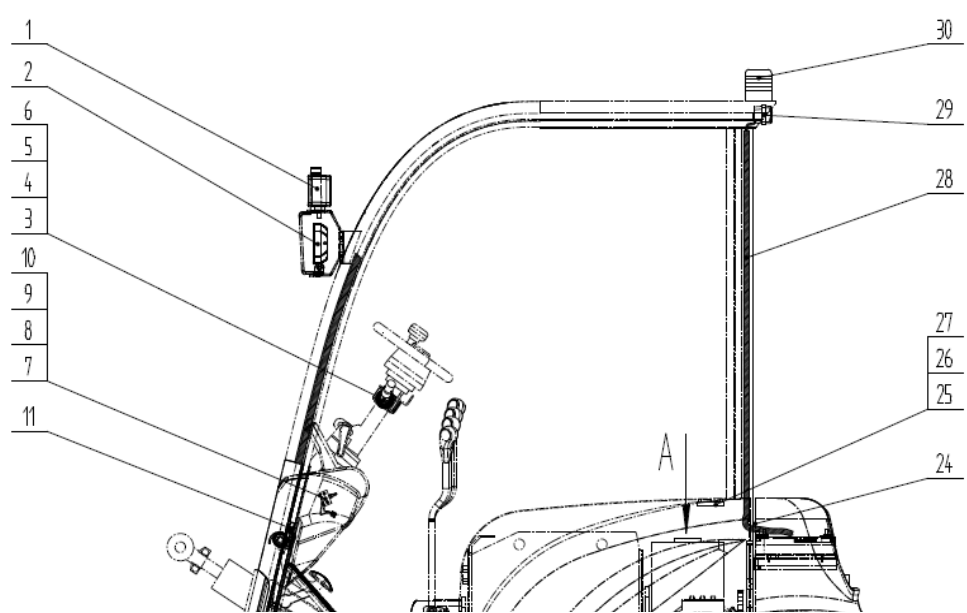

序号 Item No.	物料号 ID.	代号 Part No.	名称 Description	数量 Q' ty	备注 Remark
1	69044060	A30424-02104	Front combination lamp	2	
2	69106439	A30424-02103A	Head light	2	
3	69026711	25724-00027.	Combination switch	1	
4	69000328	GB/T818-M6*15-4. 8J	Bolt M6×15	6	GB/T818-2000
5	69000258	GB/T97. 1-6	Washer 6	11	GB/T97. 1-2002
6	69000060	GB/T93-6	Washer 6	11	GB/T93-1987
7	69000384	A25724-02008	Hand brake switch	1	25724-00031
8	69000336	GB/T818-M4*25-4. 8J	Bolt M4×25	2	GB/T818-2000
9	69000256	GB/T97. 1-4	Washer 4	6	GB/T97. 1-2002
10	69000055	GB/T93-4	Washer 4	6	GB/T93-1987
11	69000497	A25724-02010	Brake switch	2	30324-00034
12	69129870	A25724-02009	Multi-way valve switch	1	25724-00030











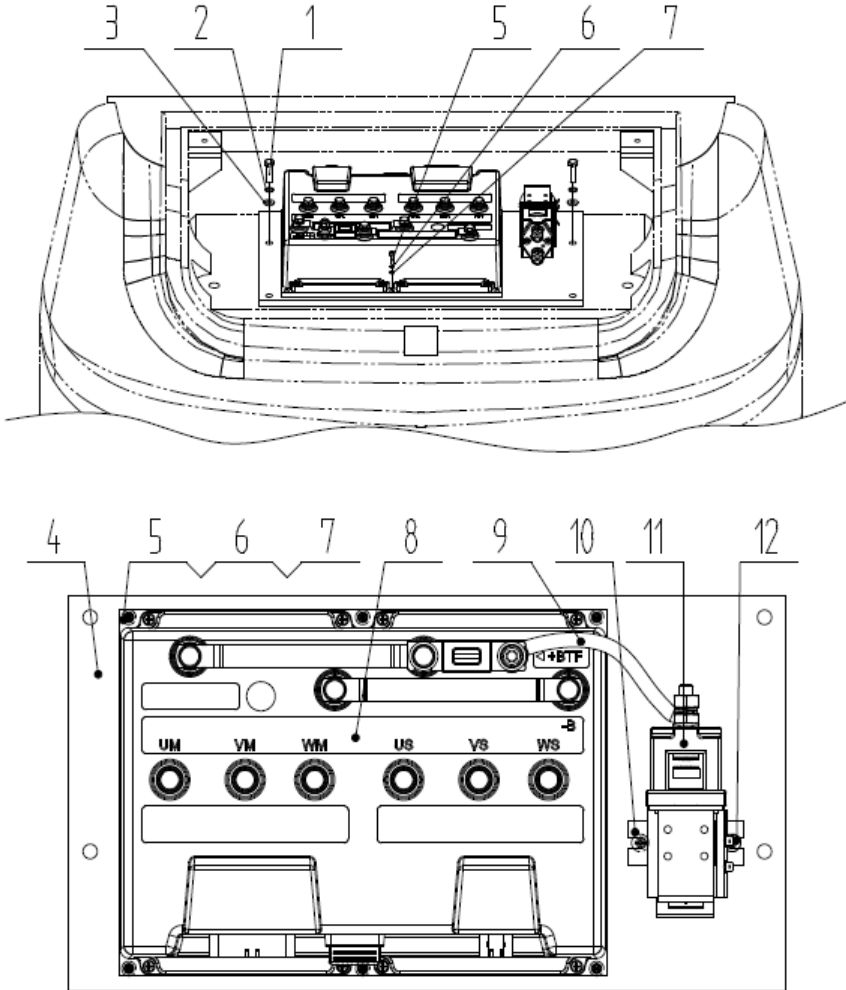

序号	物料号	代号	名称	数量	备注
Item No.	ID.	Part No.	Description	Q' ty	Remark
1	69000200	GB/T5783-M8*25-8. 8J	Bolt M8×25	4	GB/T5781-2000
2	69000062	GB/T93-8	Washer 8	4	GB/T93-1987
3	69000259	GB/T97. 1-8	Washer 8	4	GB/T97. 1-2002
4	69085368	A35708Z-01000	Aluminium plate	1	
5	69028279	GB/T70. 1-M6*35-12. 9J	Hexagon bolt M6×35	6	GB/T70. 1-2000
6	69000060	GB/T93-6	Washer 6	8	GB/T93-1987
7	69000258	GB/T97. 1-6	Washer 6	8	GB/T97. 1-2002
8	69080504	A35708Z-06000-B	Controller	1	FBA30/35-JZ
9	69067422	A25708Z-04000	Cable	1	
10	69057562	25708-04001	Contacto bracket	1	A25708Z-02001
11	69076680	A30708Z-02000	Main contactor	1	FBA30/35-JZ
12	69000328	GB/T818-M6*15-4. 8J	Bolt M6×15	2	GB/T818-2000

图10/ Fig. 10 电气系统/ Electrical System

序号	物料号	代号	名称	数量	备注
Item No.	ID.	Part No.	Description	Q' ty	Remark
1	69000200	GB/T5783-M8*25-8. 8J	Bolt M8×25	4	

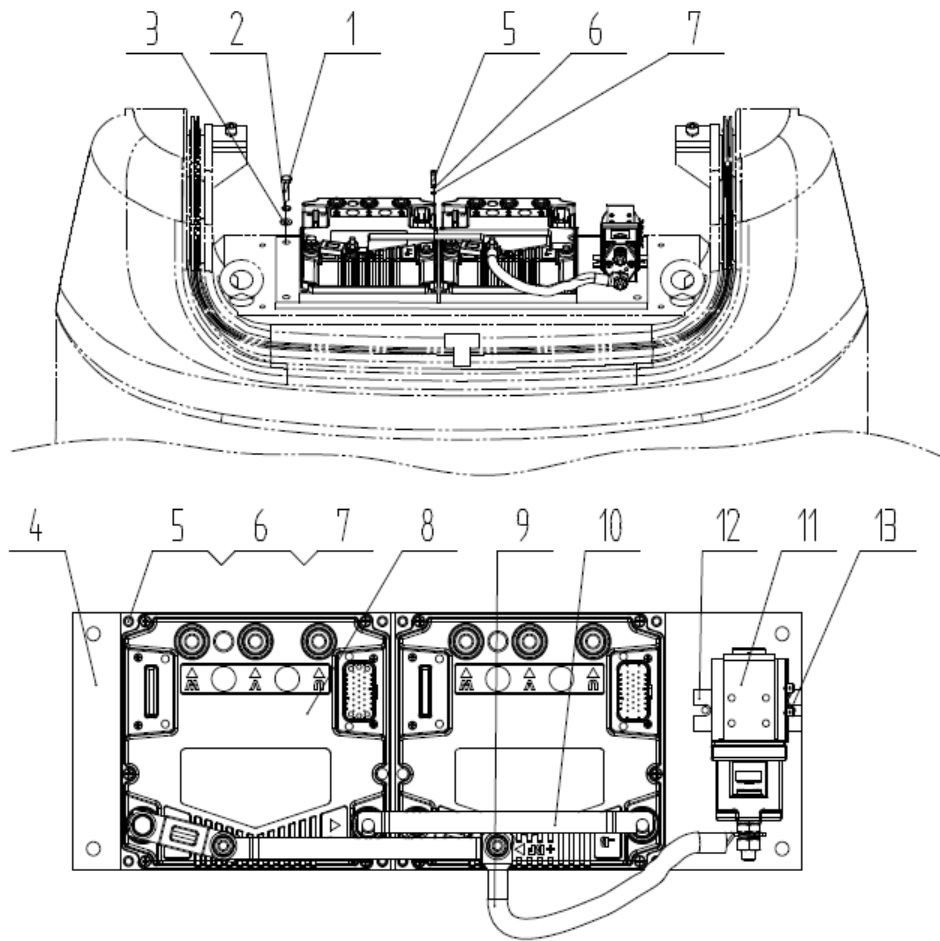

2	69000062	GB/T93-8	Washer 8	4	GB/T93-1987
3	69000259	GB/T97.1-8	Washer 8	4	GB/T97.1-2002
4	69067418	A25708Z-01000	Aluminium plate	1	
5	69028279	GB/T70.1-M6*35-12.9J	Hexagon bolt M6×35	6	GB/T70.1-2000
6	69000060	GB/T93-6	Washer 6	8	GB/T93-1987
7	69000258	GB/T97.1-6	Washer 6	8	GB/T97.1-2002
8	69067424	A25708Z-06000-B	Controller	1	FBA15/18/20/25-JZ
9	69067422	A25708Z-04000	Cable	1	
10	69067421	A25708Z-03000	Copper strip	2	
11	69057562	25708-04001	Contactator bracket	1	A25708Z-02001
12	69076264	A25708Z-02000	Main contactator	1	FBA15/18/20/25-JZ
13	69000328	GB/T818-M6*15-4.8J	Bolt M6×15	2	GB/T818-2000

图11/Fig. 11

加速器及安装/ACCELERATOR AND INSTALLATION

FBA15/18/20/25/30/35-JZ

序号 Item No.	物料号 ID.	代号 Part No.	名称 Description	数量 Q'ty	备注 Remark
1	69000198	GB/T5783-M8*20-8.8J	Bolt M8×20	2	
2	69000259	GB/T97.1-8	Washer 8	2	
3	69064545	A25725-01000	Accelerator	1	
4	69000292	GB/T889.1-M8-8J	Nut M8	2	





图12/Fig. 12 前轮总成/ FRONT WHEEL ASSEMBLY

FBA15/18/20/25/30/35-JZ

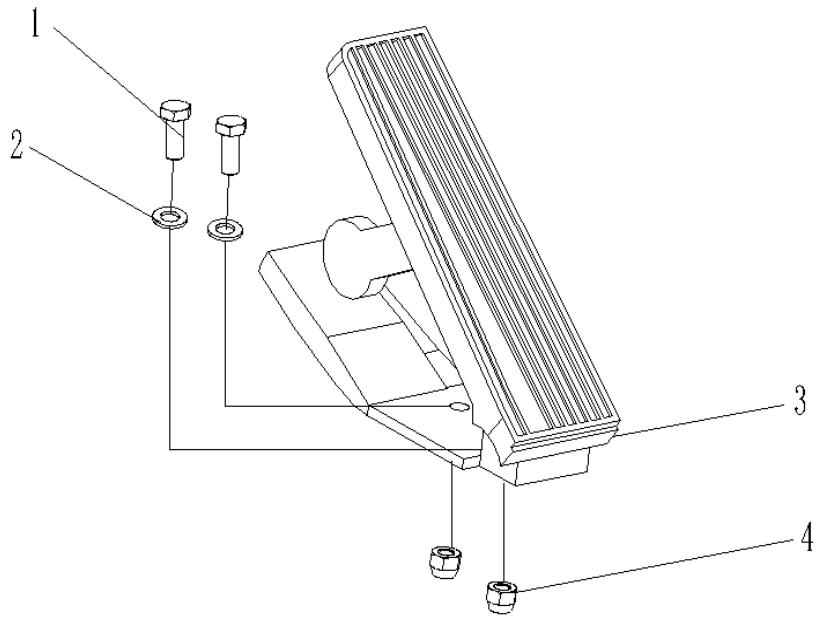
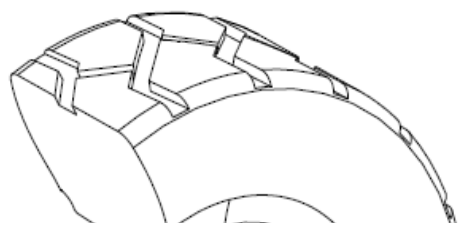
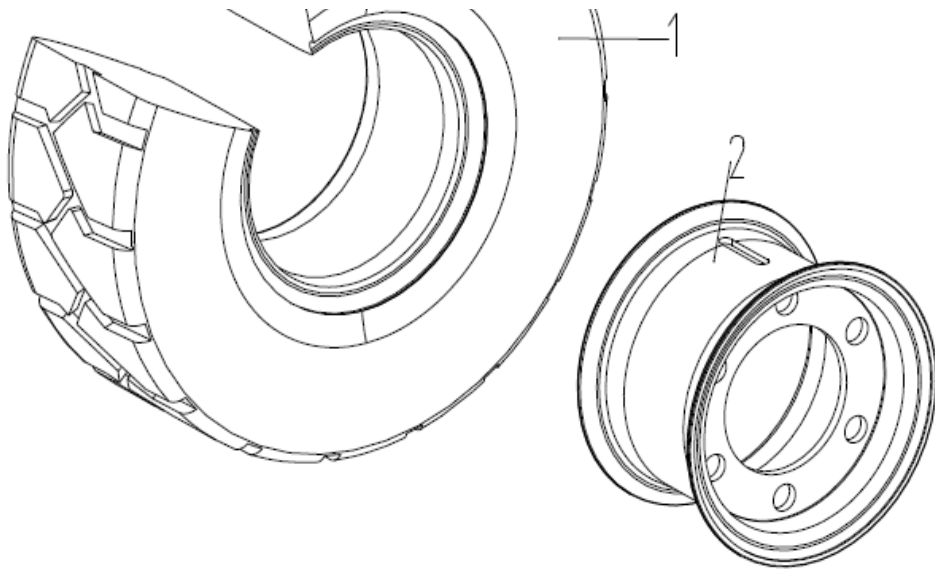

序号	物料号	代号	名称	数量	
Item No.	ID.	Part No.	Description	Q'ty	
1	69080189	A35733-02000-2-Q	Tyre (23×10-12)	2	FBA35-JZ
-	69068834	A25733-01000-1-Q	Tyre (23×9-10)	2	FBA20/25/30-JZ
-	69082137	A18733-01000-1-Q	Tyre (21×8-9)	2	FBA18-JZ
-	69068826	A15733-01000-1-Q	Tyre (6.00-9)	2	FBA15-JZ
2	69080188	A35733-01000-B	Rim (8.00G-12)	2	FBA35-JZ
-	69064548	A25733-02000-B	Rim (6.50F-10)	2	FBA20/25/30-JZ
-	69082136	A18733-02000-B	Rim (6.00E-9)	2	FBA18-JZ



-	69064662	A15733-02000-B	Rim(4.00E-9)	2	FBA15-JZ

图13/Fig. 13 转向装置及安装/ STEERING DEVICE AND INSTALLATION

FBA15/18/20/25/30/35-JZ

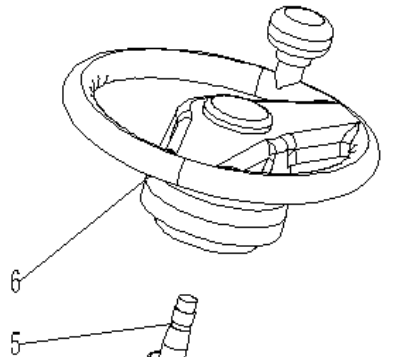

序号 Item No.	物料号 ID.	代号 Part No.	名称 Description	数量 Q' ty	
1	69034249	A30442-02000	Locking handle	1	
2	69034294	A30442-00003	Buckle	1	
3	69034293	A30442-00002	Shaft	1	
4	69034292	A30442-00001	Cushion	1	
5	69064551	A25742-01000	Steering column	1	
6	69001645	M2574201000	Steering wheel	2	
7	69034295	A30442-00004	Locking piece	1	
8	69000123	GB/T5783-M10*20-8.8J	Bolt M10×20	4	
9	69000053	GB/T93-10	Washer 10	4	
10	69034297	A30442-00006	Nut M12	2	









图16/Fig. 16

1.5-1.8T转向桥/ STEERING AXLE

FBA15/18-JZ

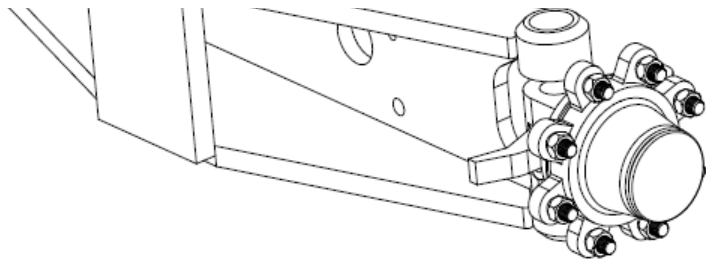
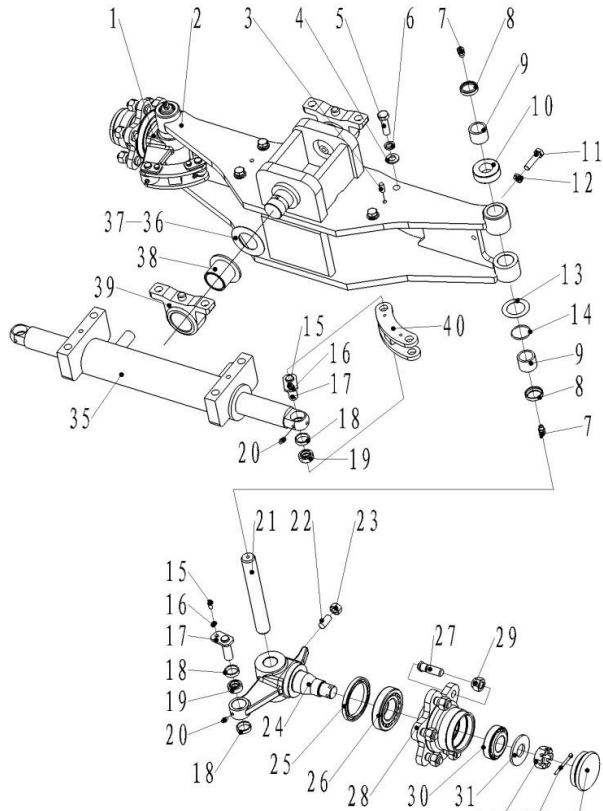
序号	物料号	代号	名称	数量	
Item No.	ID.	Part No.	Description	Q' ty	
1	69137307	H12C4-30401	Left knuckle ass'y	1	
2	69137308	Z01A1-20200	Steering axle ass'y	1	
3	69137309	B3130-08018	Cylindrical pin 8×18	2	
4	69137310	B5313-00012	Washer 12	4	
5	69135290	B0330-12040B	Bolt M12×40	4	
6	69137312	B5050-00012B	Washer 12	4	
7	69137383	Q701B45-1	Grease nipple Z1/8	6	
8	69026981	24234-32231	Oil seal Φ25×Φ32×7	4	
9	69137314	Z-942/25	Needle bearing Φ25×Φ32×22	4	
10	69022855	Z-198905	Bearing 198905	2	
11	69137315	B0530-10040B	Bolt M10×1.25×40	2	
12	69137316	B4223-00010B	Nut M10×1.25	2	
13	69026980	20114-30091	Adjusting shim set Φ26×Φ46×0.2	5	
14	69136796	24234-32241	O-ring 24.8×4.3	2	
15	69137317	B0330-06012B	Bolt M6×12	4	
16	69137318	B5050-00006B	Washer 6	4	
17	69137319	H12C4-30501B	Link pin	4	
18	69137320	H12C4-032101	Bushing	6	
19	69137321	Z-GE15ES	Oscillating knuckle bearing GE15ES	4	





20	69135313	Q700B06	Grease fitting M6	4	
21	69022857	24234-32181A	Pin	2	
22	69135297	B8050-12030B	Bolt M12×30	2	
23	69135289	B4133-00012B	Nut M12	2	

图16/Fig. 16

1.5-1.8T转向桥/ STEERING AXLE

FBA15/18-JZ

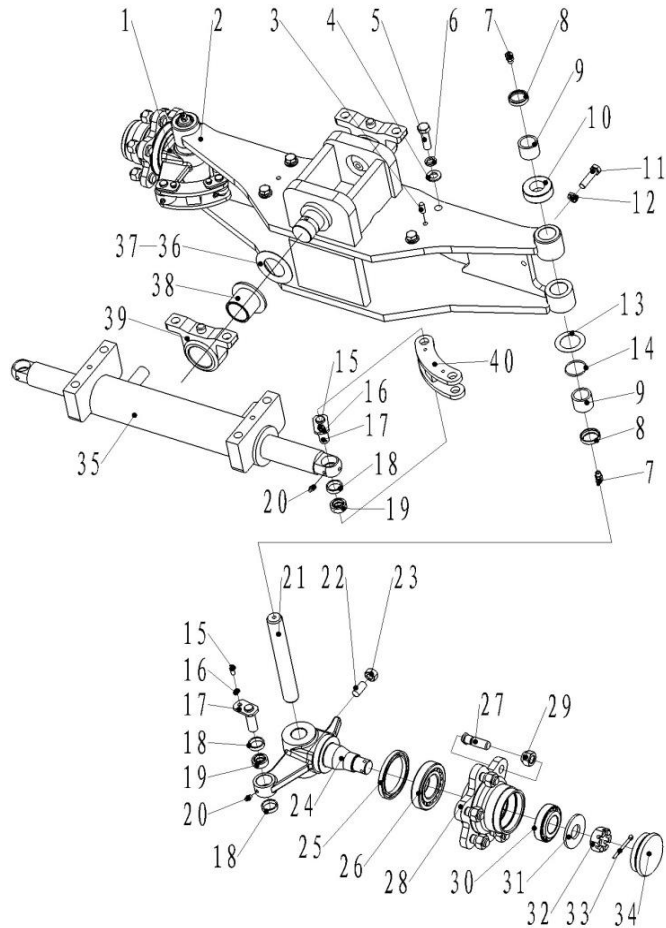

序号	物料号	代号	名称	数量	
Item No.	ID.	Part No.	Description	Q'ty	
24	69137322	H12C4-30301	Right knuckle ass'y	1	
25	69137323	22574-32102	Oil seal $\Phi 64 \times \Phi 82 \times 7$	2	
26	69137324	Z-30208	Tapered roller bearing 30208	2	
27	69137325	Z01A2-10200	Bolt	12	
28	69026111	24234-32221	Hub	2	
29	69130891	23654-34051B	Nut	12	
30	69137326	Z-30206	Tapered roller bearing 30206	2	
31	69137327	G15X4-32111	Washer $\Phi 25 \times \Phi 58 \times 4$	2	
32	69137328	24234-32311	Cotter nut M24×2	2	
33	69137329	B3010-05040	Cotter pin 5×40	2	
34	69137330	22194-32361N	Wheel hub cover	2	
35	69137331	Z01A3-24000	Steering cylinder	1	
36	69137332	23458-32501	Adjusting shim set $\Phi 76 \times \Phi 43 \times 0.5$	2	
37	69055693	23458-52031	Adjusting shim set $\Phi 76 \times \Phi 43 \times 1$	2	
38	69137333	Z01A1-20210	Bushing	2	
39	69137334	Z01A1-20209	Rear axle bearing	2	
40	69137335	HRH12C4302B	Connecting rod	2	

图17/Fig. 17

## 2.0-2.5T转向桥/ STEERING AXLE

FBA20/25-JZ

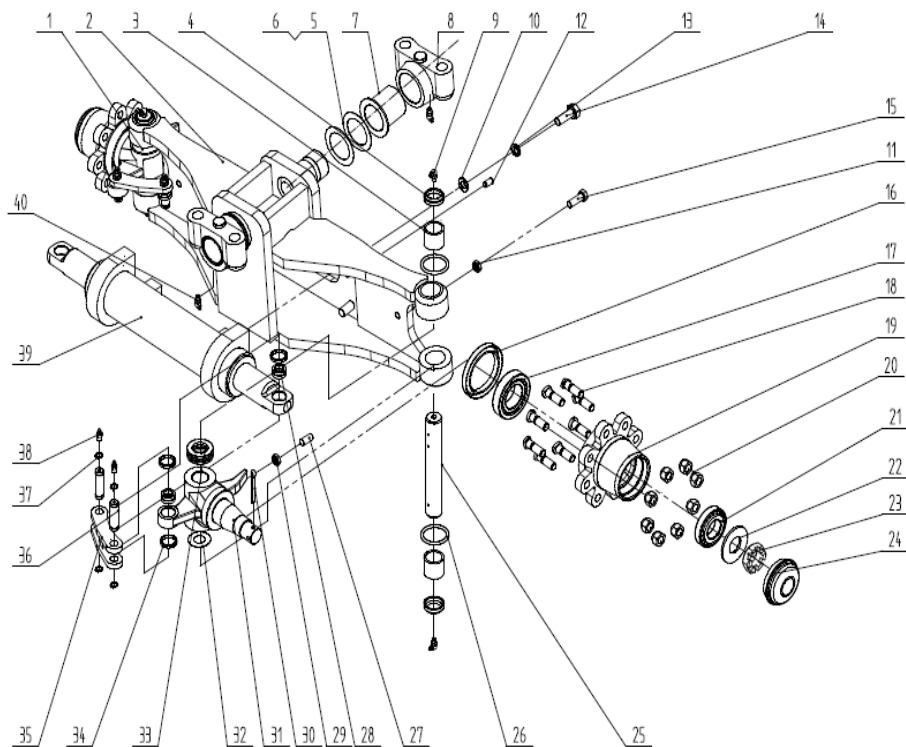

序号	物料号	代号	名称	数量
Item No.	ID.	Part No.	Description	Q'ty
1	69058090	A73E4-30401	Left knuckle ass'y	1
2	69137336	Z02A1-20200	Steering axle ass'y	1
3	69135304	Z-943/32	Needle bearing Φ32×Φ40×32	4
4	69003338	23654-32081	Oil seal Φ32×Φ40×7	4
5	69089525	A21B4-32291	Adjusting shim setΦ53×Φ76×0.5	4
6	69089524	A21B4-32301	Adjusting shim setΦ53×Φ76×2	4
7	69137337	Z03K1-010205	Bushing	2
8	69137338	Z02A1-20210	Rear axle bracket	4
9	69135303	Q701B90	Grease nipple Z1/8	6
10	69135291	B5313-00014	Washer 14	4
11	69135289	B4133-00012B	Nut M12	2
12	69130896	B3130-10020	Cylindrical pin 10×20	2
13	69135292	B5050-00014B	Washer 14	4
14	69137339	B0330-14040B	Bolt M14×40	4
15	69136332	B0330-12035B	Bolt M12×35	2
16	69136414	Z6301-07523	Oil seal Φ75×Φ100×10	2
17	69136400	Z-32209	Tapered roller bearing 32209	2
18	69135298	23654-32041B	Bolt	16
19	69030253	A73J4-32151	Hub	2
20	69130891	23654-34051B	Nut	16
21	69135301	Z-30207	Tapered roller bearing 30207	2
22	69092923	G27Z4-30711	Washer Φ31×Φ62×4	2
23	69005337	A21B4-32311	Cotter nut M30×2	2

图17/Fig. 17

## 2.0-2.5T转向桥/ STEERING AXLE

FBA20/25-JZ

序号	物料号	代号	名称	数量
----	-----	----	----	----

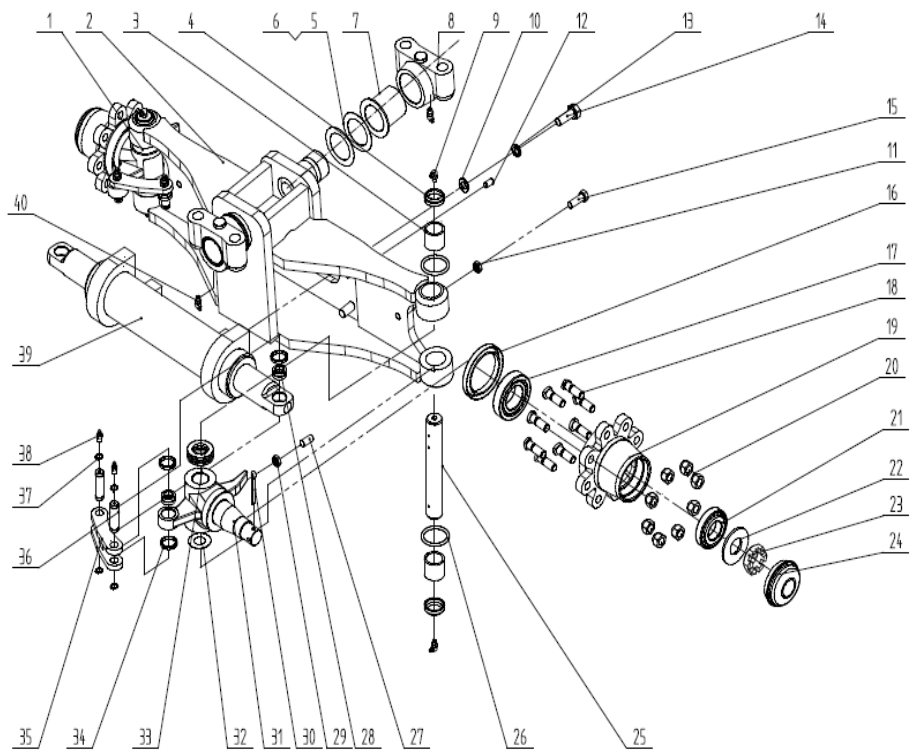

Item No.	ID.	Part No.	Description	Q' ty
24	69135299	1218-10200	Wheel hub cover	2
25	69136337	A73J4-32111	Master pin	2
26	69135305	23654-32161	O-ring 31.8×4.8	2
27	69135297	B8050-12030B	Bolt M12×30	2
28	69135312	Z-GE16ES	Oscillating knuckle bearing GE16ES	4
29	69136406	B4333-00012B	Nut M12	2
30	69130894	B3010-6P350	Cotter pin 6.3×50	2
31	69058089	A73E4-30301	Right knuckle ass'y	1
32	69135306	22214-30321	Adjusting shim set Φ32.5×Φ65×0.2	2
33	69136402	Z-198906	Bearing 198906	2
34	69135314	H24C4-12003	Bushing	6
35	69137340	A73E4-32001B	Connecting rod	2
36	69137341	A73J4-32022B	Link pin	4
37	69136415	58903	Axis circlip	8
38	69135313	Q700B06	Grease fitting M6	4
39	69094024	Z02A3-24000	Steering cylinder ass'y	1
40	69137384	Q701B45-2	Grease nipple ZBT33001.1-88	2

图18/Fig. 18 3.0T转向桥/ STEERING AXLE

FBA30/35-JZ
-------------

序号	物料号	代号	名称	数量	备注
Item No.	ID.	Part No.	Description	Q' ty	Remark
1	69130896	B3130-10020	Cylindrical pin 10×20	2	
2	69135292	B5050-00014B	Washer 14	4	

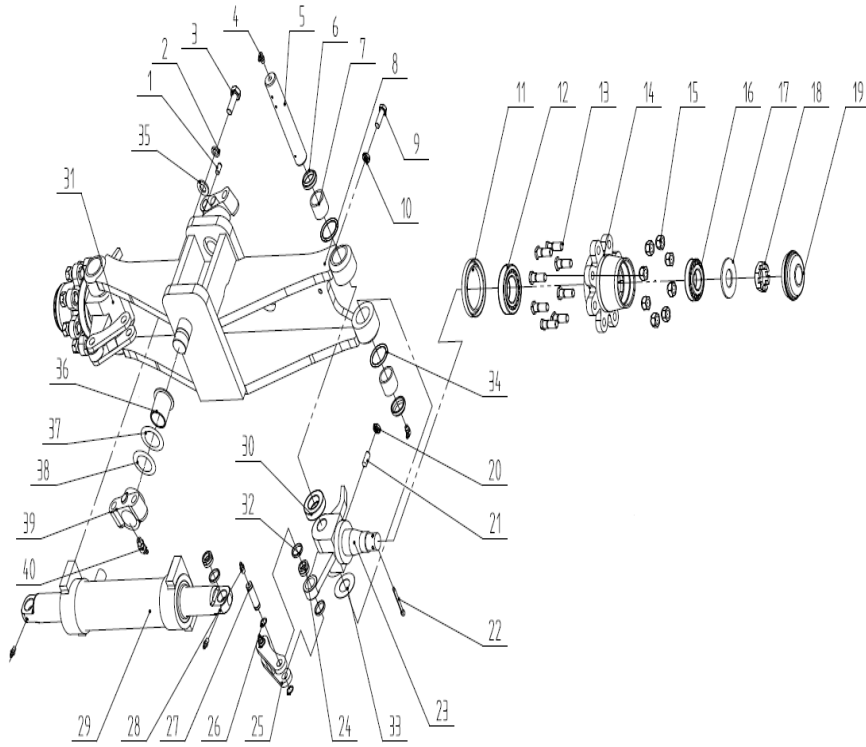

3	69135293	B0330-14045B	Bolt M14×45	4	
4	69135303	Q701B90	Grease fitting Z1/8	6	
5	69136337	A73J4-32111	Master pin	2	
6	69003338	23654-32081	Oil seal Φ32×Φ40×7	4	
7	69135304	Z-943/32	Needle bearing Φ32×Φ40×32	4	
8	69136378	Z03A2-20200	Steering axle ass'y	1	
9	69136332	B0330-12035B	Bolt M12×35	2	
10	69136406	B4333-00012B	Nut M12	2	
11	69136414	Z6301-07523	Oil seal Φ75×Φ100×10	2	
12	69136400	Z-32209	Tapered roller bearing 32209	2	
13	69135298	23654-32041B	Bolt	16	
14	69030253	A73J4-32151	Hub	2	
15	69130891	23654-34051B	Nut	16	
16	69135301	Z-30207	Tapered roller bearing 30207	2	
17	69092923	G27Z4-30711	Washer Φ31×Φ62×4	2	
18	69005337	A21B4-32311	Cotter nut M30×2	2	
19	69135299	1218-10200	Wheel hub cover	2	
20	69136406	B4333-00012B	Nut M12	2	
21	69135297	B8050-12030B	Bolt M12×30	2	
22	69130894	B3010-6P350	Cotter pin 6.3×50	2	
23	69003535	A73J4-30302	Right knuckle ass'y	1	

图18/Fig. 18 3. 0T转向桥/ STEERING AXLE

FBA30/35-JZ

序号	物料号	代号	名称	数量	备注
Item No.	ID.	Part No.	Description	Q'ty	Remark
24	69135312	Z-GE16ES	Oscillating knuckle bearing GE16ES	4	
25	69136405	A73J4-32081BX	Connecting rod	2	
26	69136415	58903	Axis circlip	8	
27	69136401	A73J4-32022	Link pin	4	
28	69135313	Q700B06	Grease fitting M6	6	

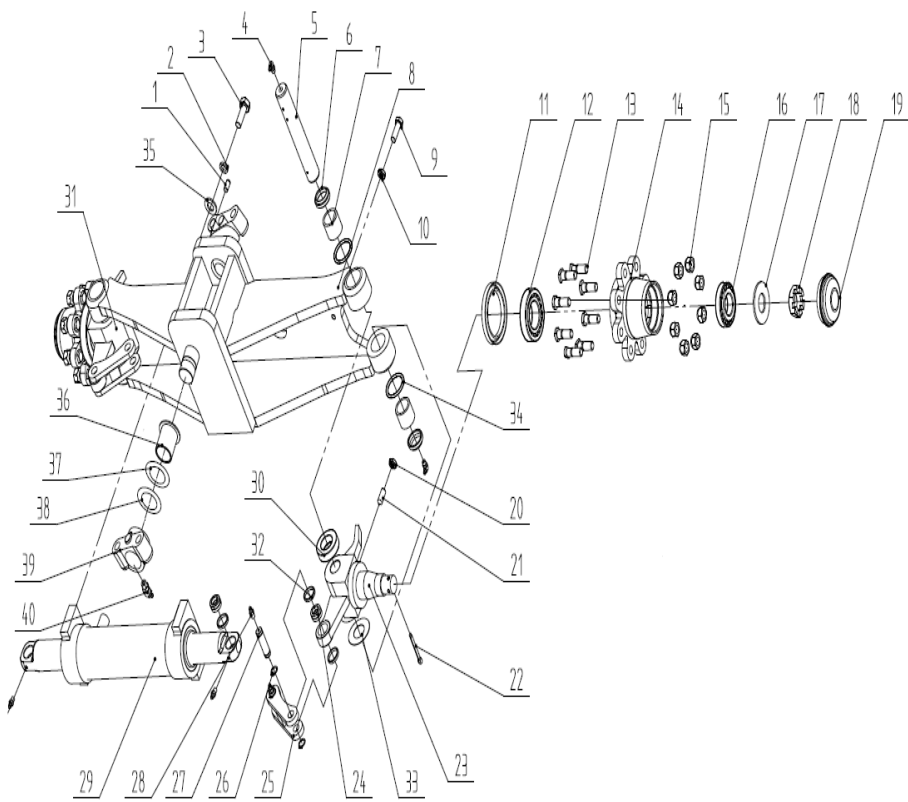

29	69136408	A21B4-30401KP	Steering cylinder	1	
30	69136402	Z-198906	Bearing 198906	2	
31	69005025	A73J4-30402	Left knuckle ass'y	1	
32	69135314	H24C4-12003	Bushing	6	
33	69135306	22214-30321	Adjusting shim set	2	
34	69135305	23654-32161	O-ring 31.8×4.8	2	
35	69135291	B5313-00014	Washer 14	4	
36	69137343	Z03K1-10205	Bushing	2	
37	69089525	A21B4-32291	Adjusting shim set Φ53×Φ76×0.5	2	
38	69089524	A21B4-32301	Adjusting shim set Φ53×Φ76×2	4	
39	69137338	Z02A1-20210	Rear axle bracket	2	
40	69137383	Q701B45-1	Grease fitting	2	

图19/Fig. 19 2. 5T转向桥(林德)/ STEERING AXLE

FBA20/25-JZ

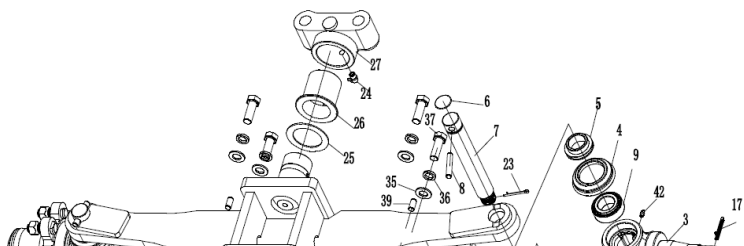

序号	物料号	代号	名称	数量	备注
Item No.	ID.	Part No.	Description	Q'ty	Remark
1	69138527	A25743-01100A	Steering axle ass'y	1	
2	69138528	Z25LDD-0300C-A (AH)	Steering cylinder	1	
3	69138529	A25743-01001A	Right knuckle	1	
4	69138530	ZZ3050LD-1004	Upper dust cover	2	
5	69138531	ZZ3050LD-1003	Upper support sleeve	2	
6	69136443	GB/T1235-1976	O-ring Φ30×Φ2.5	2	
7	69138532	ZZ305LD-1001	Master pin	2	
8	69136338	Z30LDD-0130 (AH)	pin	2	

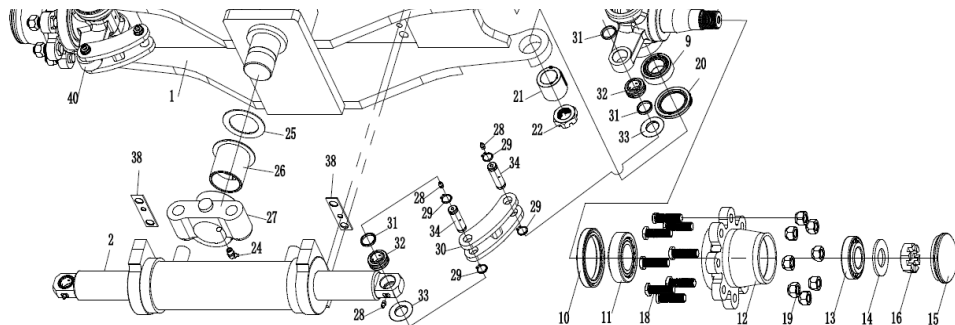

9	69026294	GB/T297-32206	Tapered roller bearing 32206	4	
10	69138533	GB/T 13871-75*100*12	Seal ring 75×100×12	2	
	69136363	GB297-94-01	Tapered roller bearing 32209	2	
12	69136371	Z25LDD-0501 (AH)	Hub	2	
13	69136168	GB/T297	Tapered roller bearing 32207	2	
14	69007049	GB/T97.1-AJ30	Washer 30	2	
15	69005336	A21B4-32231	Wheel hub cover	2	
16	69005337	A21B4-32311	Nut M30×2	2	
17	69138536	GB/T 91-6.3×45	Cotter pin 3.2×45	2	
18	69135298	23654-32041B	Bolt	16	
19	69130891	23654-34051B	Nut	16	
20	69138538	A25743-01003A	Oil seal	2	
21	69138539	ZZ3050LD-1002	Lower support sleeve	2	
22	69138540	ZZ3050LD-1007	Nut	2	
23	69138541	GB/T 91-3.2×45	Cotter pin 3.2×45	2	

图19/Fig. 19

2. 5T转向桥(林德)/ STEERING AXLE

FBA20/25-JZ

序号	物料号	代号	名称	数量	备注
Item No.	ID.	Part No.	Description	Q'ty	Remark
24	69138542	JB/T 7940.2-1995	Oil cup	2	
25	69073446	Z30LS-30021	Adjusting shim set	4	
26	69138543	Z03A2-20202	Bushing	2	
27	69138544	Z03A2-20201	Bearing seat	2	
28	69138545	JB/T 7940.1- M6*1	Grease fitting	6	
29	69138546	GB/T 894.1-16	Ring	8	
30	69136398	Z25LDD-0312 (AH)	Connecting rod	2	
31	69135314	H24C4-12003	Bushing	6	
32	69000585	H24C4-32061	Knuckle bearing GE16ES	4	
33	69136251	A21B4-32281	Adjusting shim set	4	
34	69136398	Z25LDD-0312 (AH)	Link pin	4	

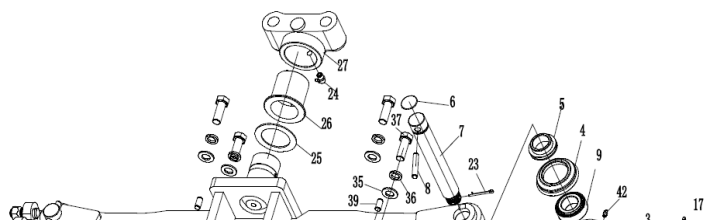

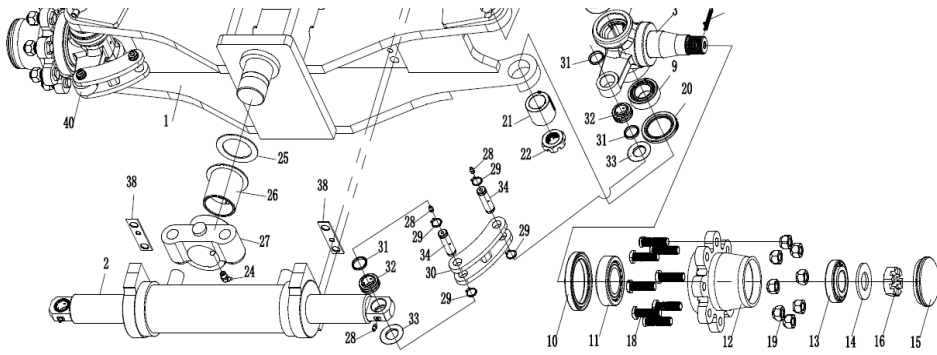

35	69138548	GB/T95-14	Washer 14	4	
36	69005111	GB/T93-14	Washer 14	4	
37	69138549	GB/T5782-M14*45	Bolt M14×45	4	
38	69135306	22214-30321	Adjusting shim set	4	
39	69138550	GB/T 119-10*20	Cylindrical pin 10×20	2	
40	69138551	A25743-01002A	Left knuckle	1	

图20/ Fig. 20 转向油缸/ STEERING CYLINDER

FBA15/18/20/25/30/35-JZ

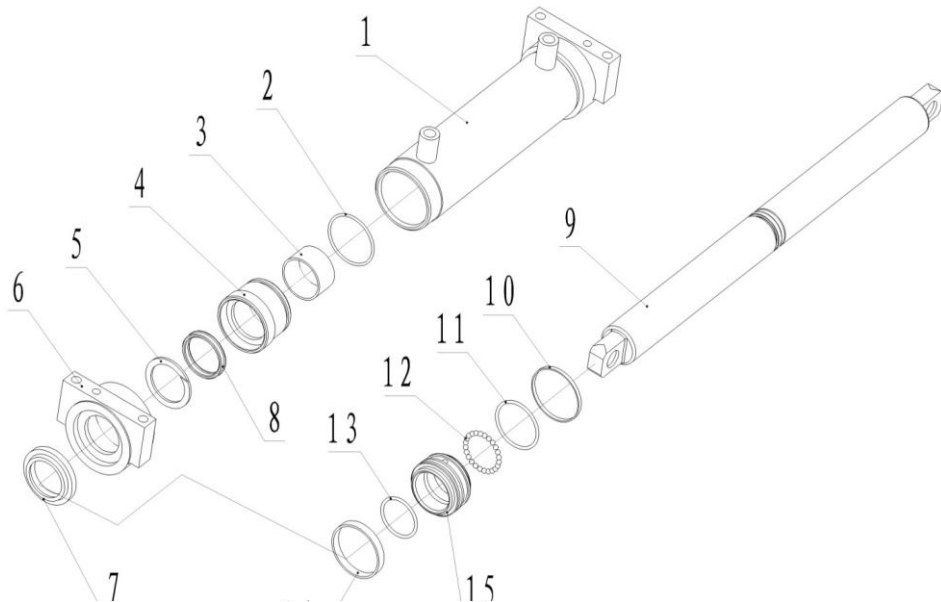

序号 Item No.	物料号 ID.	代号 Part No.	名称 Description	数量 Q'ty	备注 Remark
1	69137345	A21B4-30501KP	Cylinder body	1	
2	69137346	C0 0208B1	O-ring D64.4×3.1	2	
3	69137347	Z2114-05030	Bushing bearing 5030	2	
4	69137348	Z02A3-24002	Shaft installing	2	
5	69137349	24328-52211	Stop 50×65×3	2	
6	69137350	A21B4-32151	Cylinder cover	2	
7	69137351	24329-45581	Dustproof seal 50×72×8/11	2	
8	69137352	FU0630F0	Gasket ring 50×65×9	2	
9	69136724	H24C4-52153A	Piston rod	1	
10	69136217	H24C4-52171	Pivot ring	1	
11	69137353	C0 7284A0	P-ring 60×3.55	1	
12	69136156	Z1505-00060	Steel ball Φ6	25	
13	69137354	Z6053-05003	O-ring D50×3.5	1	
14	69129765	H24C4-53001S	Pivot ring 70×10×2.5	1	









图22/Fig. 22

护顶架及安装/ OVERHEAD GUARD ASS'Y

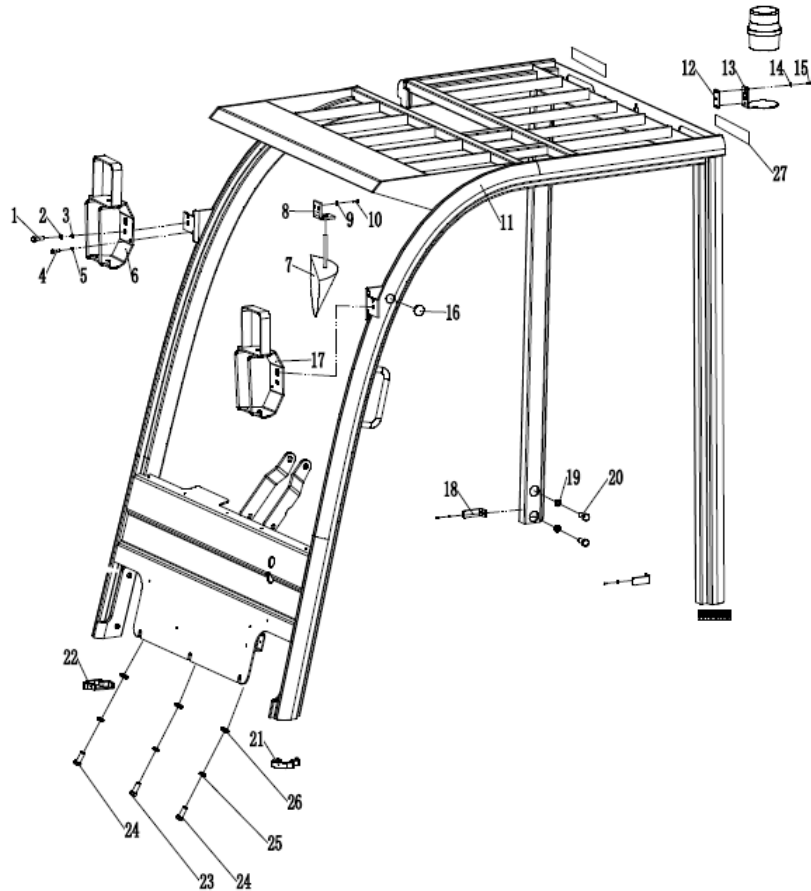
FBA15/18/20/25/30/35-JZ



序号	物料号	代号	名称	数量	备注
Item No.	ID.	Part No.	Description	Q'ty	Remark
1	69000123	GB/T5783-M10*20-8.8J	Bolt M10×20	2	
2	69000053	GB/T93-10	Washer 10	2	
3	69000103	GB/T6170-M10-8J	Nut M10	2	
4	69000190	GB/T5783-M6*16-8.8J	Bolt M6×16	2	
5	69000060	GB/T93-6	Washer 6	2	
6	69060042	A30451-03000A	Right lamp holder	1	
7	69005400	A15Q51-00001	Rearview mirror	1	
8	69036498	A30451-00002A	Rearview mirror bracket	1	
9	69000062	GB/T93-8	Washer8	2	
10	69000309	GB/T5783-M8*16-8.8J	Bolt M8×16	2	
11	69101705	A15751-01000-Black	Top shelf-Black	1	FBA15/18-JZ
-	69101717	A25751-01000-Black	Top shelf-Black	1	FBA20/25-JZ
-	69101728	A30751-01000-Black	Top shelf-Black	1	FBA30/35-JZ
12	69071523	M30351-00003	Gasket	1	
13	69086990	30351M-00002A	Warning lamp holder	1	
14	69000060	GB/T93-6	Washer 6	2	
15	69000189	GB/T5783-M6*12-8.8J	Bolt M6×12	2	
16	69023129	30351M-00001	Rubber stopper	2	
17	69060041	A30451-02000A	The left lamp holder	1	
18	69103420	M2575100002-Black	Fixed plate-Black	2	



图23/Fig. 23

手制动操纵/ HAND BRAKE CONTROL

FBA15/18/20/25/30/35-JZ

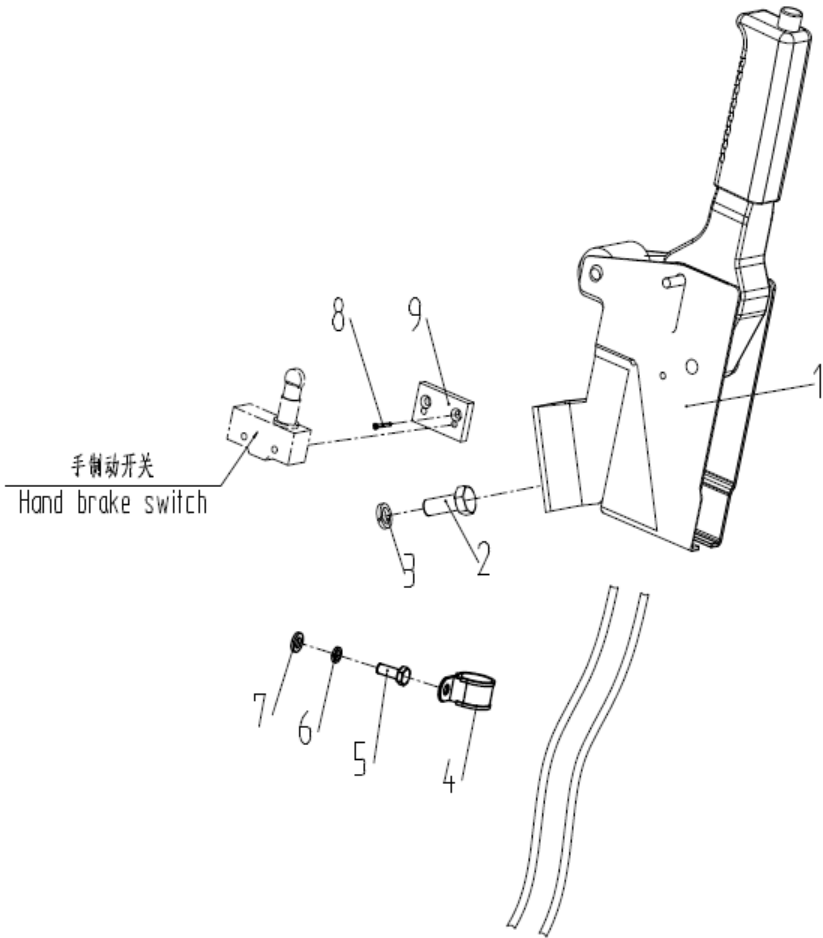

序号	物料号	代号	名称	数量	备注
Item No.	ID.	Part No.	Description	Q'ty	Remark
1	69063242	A25755-01000	Hand braking	1	2019.07.01以前
2	69000125	GB/T5783-M10*25-8.8J	Hexagon bolt M10×25	2	
3	69000053	GB/T93-10	Washer 10	2	
4	69004345	M2575500001	Cable clamp	1	
5	69000190	GB/T5783-M6*16-8.8J	Bolt M6×16	1	
6	69000060	GB/T93-6	Washer 6	1	
7	69000258	GB/T97.1-6	Washer 6	1	
8	69000160	GB/T5786-M14*1.5*45-8.8J	Bolt M4×10	2	
9	69101769	A25755-00001-L-Black	Hand brake plate-Black	1	

图23/Fig. 23

手制动操纵/ HAND BRAKE CONTROL

FBA15/18/20/25/30/35-JZ

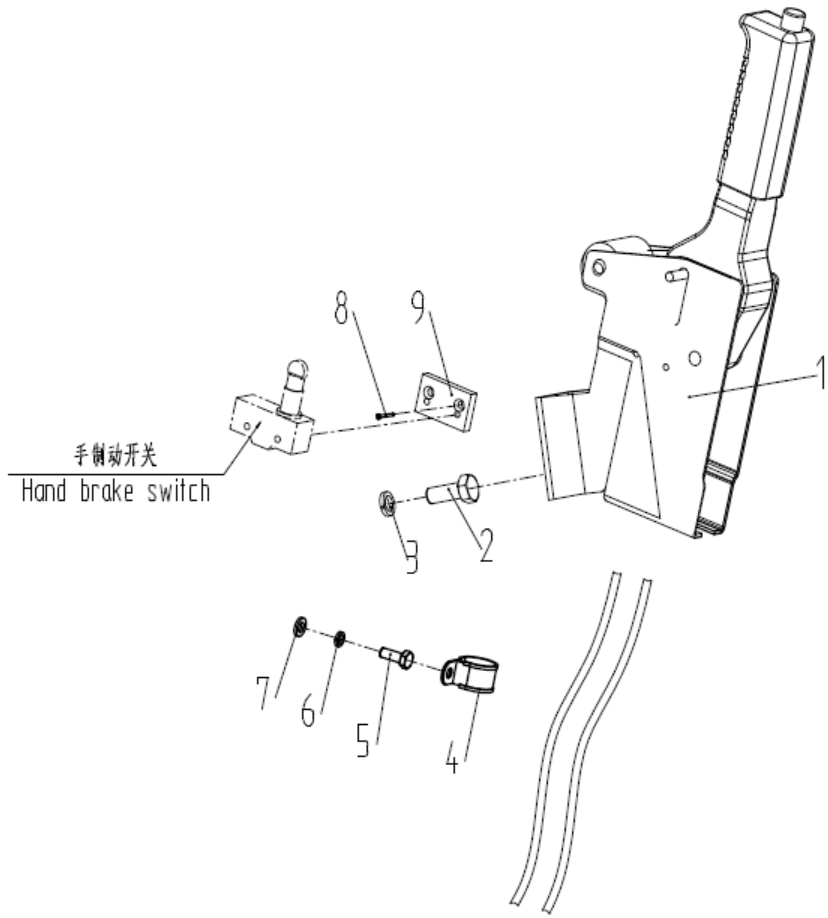

序号	物料号	代号	名称	数量	备注
Item No.	ID.	Part No.	Description	Q' ty	Remark
1	69096550	A25755-01000L	Hand braking	1	2019.07.01以后
2	69000125	GB/T5783-M10*25-8.8J	Hexagon bolt M10×25	2	
3	69000053	GB/T93-10	Washer 10	2	
4	69004345	M2575500001	Cable clamp	1	
5	69000190	GB/T5783-M6*16-8.8J	Bolt M6×16	1	
6	69000060	GB/T93-6	Washer 6	1	
7	69000258	GB/T97.1-6	Washer 6	1	
8	69000160	GB/T5786-M14*1.5*45-8.8J	Bolt M4×10	2	
9	69101769	A25755-00001-L-Black	Hand brake plate-Black	1	

图24/Fig. 24 脚制动操纵/ FOOT BRAKE CONTROL

FBA20/25/30/35-JZ

序号	物料号	代号	名称	数量	备注
Item No.	ID.	Part No.	Description	Q' ty	Remark
1	69064656	A25757-01000	Brake tube left	1	

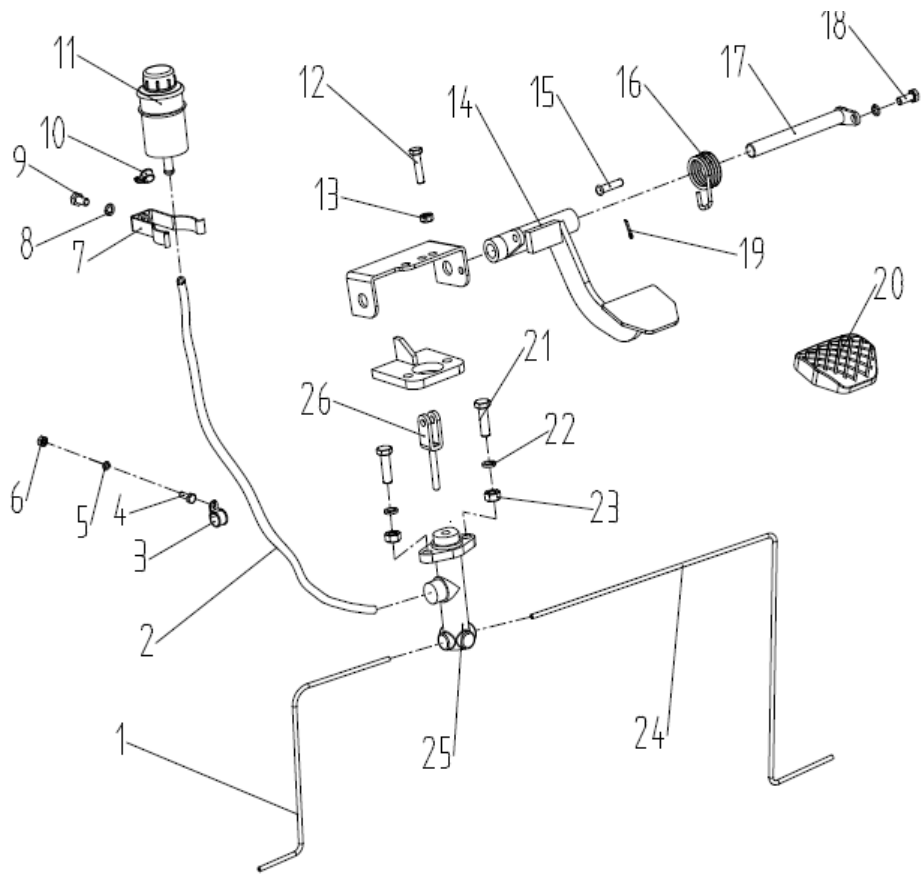

2	69131067	M2575700001	Flexible brake hose	1	用69020483剪
3	69065125	GMS-DJRX	Pipe clamp 9.5	1	自2020.03.09停用
4	69000190	GB/T5783-M6*16-8.8J	Bolt M6×16	1	自2020.03.09停用
5	69000060	GB/T93-6	Washer 6	1	自2020.03.09停用
6	69000111	GB/T6170-M6-8J	Nut M6	1	自2020.03.09停用
7	69001973	M3035405000	Oil storage tank	1	
8	69000062	GB/T93-8	Washer 8	2	
9	69000309	GB/T5783-M8*16-8.8J	Bolt M8×16	1	
10	69000052	JB/T8870-10-16	Hoop 10-16	2	
11	69001972	M3035401000	Oil tank	1	
12	69000311	GB/T5783-M8*35-8.8J	Bolt M8×35	1	
13	69000111	GB/T6170-M8-8J	Nut M8	1	
14	69087925	A25757-03000	Foot pedal	1	
15	69041330	GB/T882-Φ8*28	Pin B8×28	1	
16	69022738	45757-01001	Torsional spring	1	
17	69055606	45757-01300	Pin shaft	1	
18	69000198	GB/T5783-M8*20-8.8J	Bolt M8×20	1	
19	69020760	GB/T91-2*25	Cotter pin 2×25	1	
20	69086401	A25757-00001	Pedal pad	1	
21	69000130	GB/T5783-M10*35-8.8J	Bolt M10×35	2	
22	69000053	GB/T93-10	Washer 10	2	
23	69000103	GB/T6170-M10-8J	Nut 10	2	

图24/Fig. 24

脚制动操纵/ FOOT BRAKE CONTROL

FBA20/25/30/35-JZ

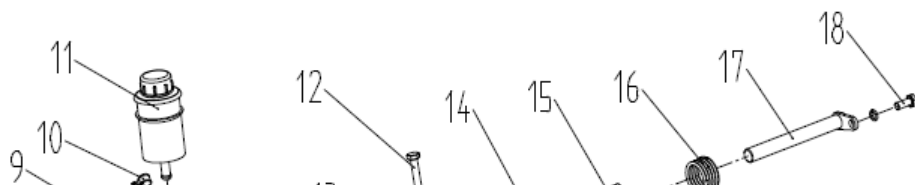

序号 Item No.	物料号 ID.	代号 Part No.	名称 Description	数量 Q'ty	备注 Remark
24	69064658	A25757-02000	Brake tube right	1	
25	69021885	M3035402300	Brake pump	1	
26	69025272	45757-01400	Handspike	1	





图25/ Fig. 25 脚制动操纵 / FOOT BRAKE CONTROL

FBA15/18-JZ

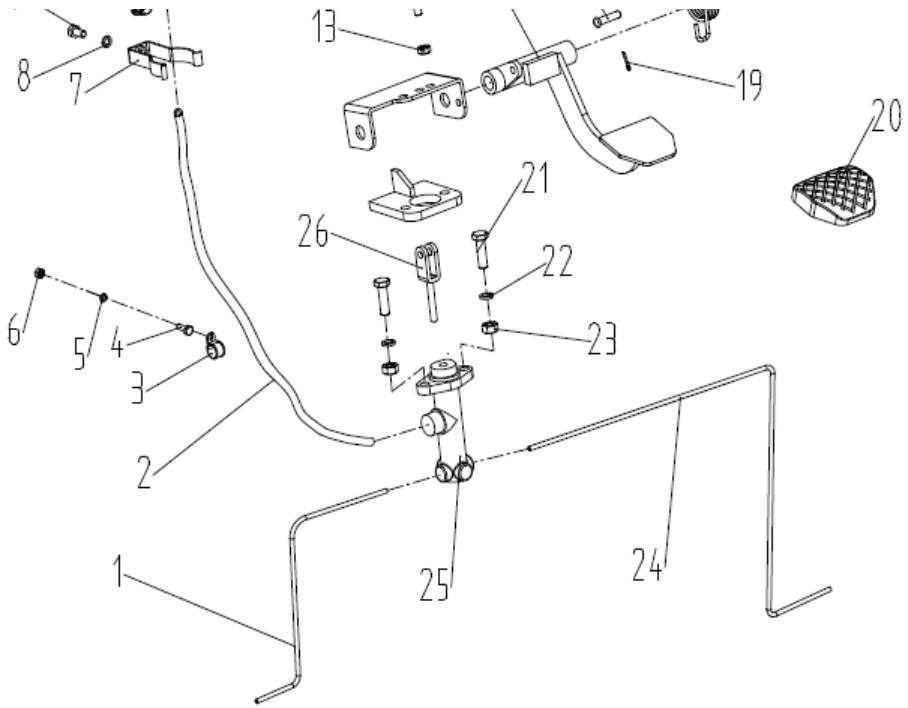
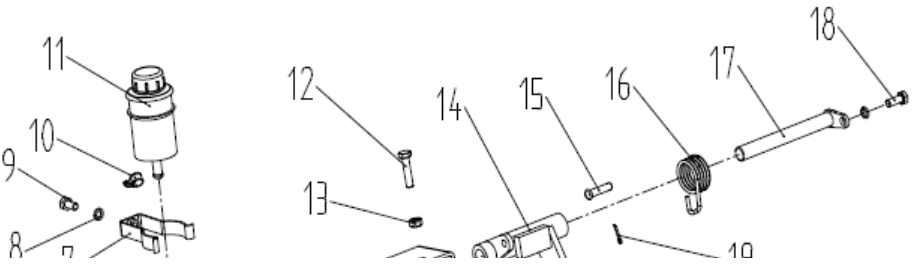

序号 Item No.	物料号 ID.	代号 Part No.	名称 Description	数量 Q'ty	备注 Remark
1	69067414	A15757-01000	Brake tube left	1	
2	69131067	M2575700001	Flexible brake hose	1	用69020483剪
3	69065125	GMS-DJRX	Pipe clamp 9.5	1	自2020.03.09停用
4	69000190	GB/T5783-M6*16-8.8J	Bolt M6×16	1	自2020.03.09停用
5	69000060	GB/T93-6	Washer 6	1	自2020.03.09停用
6	69000111	GB/T6170-M6-8J	Nut M6	1	自2020.03.09停用
7	69001973	M3035405000	Oil storage tank	1	







图26/Fig. 26 车架/ CHASSIS BODY

FBA15/18/20/25/30/35-JZ

序号	物料号	代号	名称	数量	备注
Item No.	ID.	Part No.	Description	Q' ty	Remark
1	69101736	A35761-00000A-MRed	Frame-Mred	1	FBA35-JZ
-	69101729	A30761-00000-MRed	Frame-Mred	1	FBA30-JZ
-	69101718	A25761-00000-1-MRed	Frame-Mred	1	FBA20/25-JZ
-	69101706	A15761-00000-MRed	Frame-Mred	1	FBA15/18-JZ

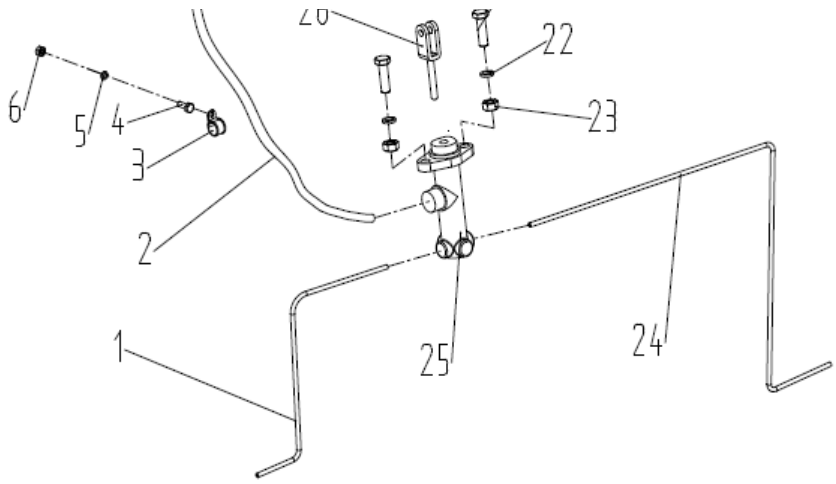
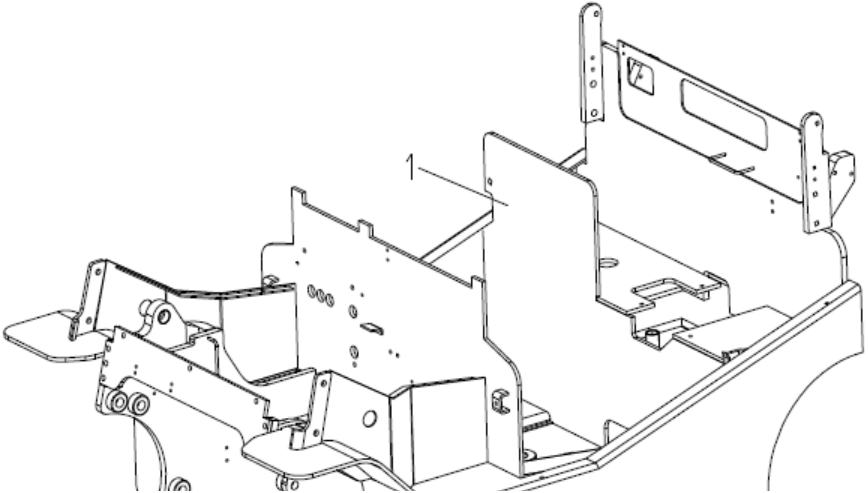







图27/ Fig. 27 平衡重/ COUNTER WEIGHT

FBA20/25/30/35-JZ

序号 Item No.	物料号 ID.	代号 Part No.	名称 Description	数量 Q'ty	备注 Remark
1	69023464	JB/T7274.4-1994	Star shaped handle M8×16	2	
2	69064705	A25763-01000	Electronic control board	1	
3	69059259	M30350-00002Z	Weatherstrip	2	用69059259剪
4	69000076	GB/T825-M20	Bolt M20	2	取消
5	69000198	GB/T5783-M8*20-8.8J	Bolt M8×20	2	
6	69000062	GB/T93-8	Washer 8	2	
7	69000259	GB/T97.1-8	Washer 8	2	
8	69015140	M3036300006-1mm	Adjusting washer-1mm	2-4	
	69015141	M3036300006-2mm	Adjusting washer-2mm	2-4	
9	69101738	A35763-00001A-Mred	Counter weight-MRed	1	FBA35-JZ
-	69101730	A30763-00001-Mred	Counter weight-MRed	1	FBA30-JZ
-	69101719	A25763-00001-Mred	Counter weight-MRed	1	FBA25-JZ
-	69101716	A20763-00001-Mred	Counter weight-MRed	1	FBA20-JZ
10	69005115	M3036300004	Flat washer	1	
11	69000058	GB/T93-30	Washer 30	1	
12	69005958	GB/T5782-M30*150-8.8J	Bolt M30×150	1	FBA20/25/30-JZ

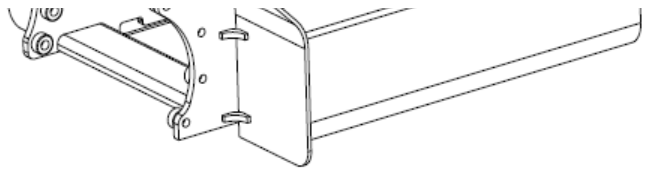
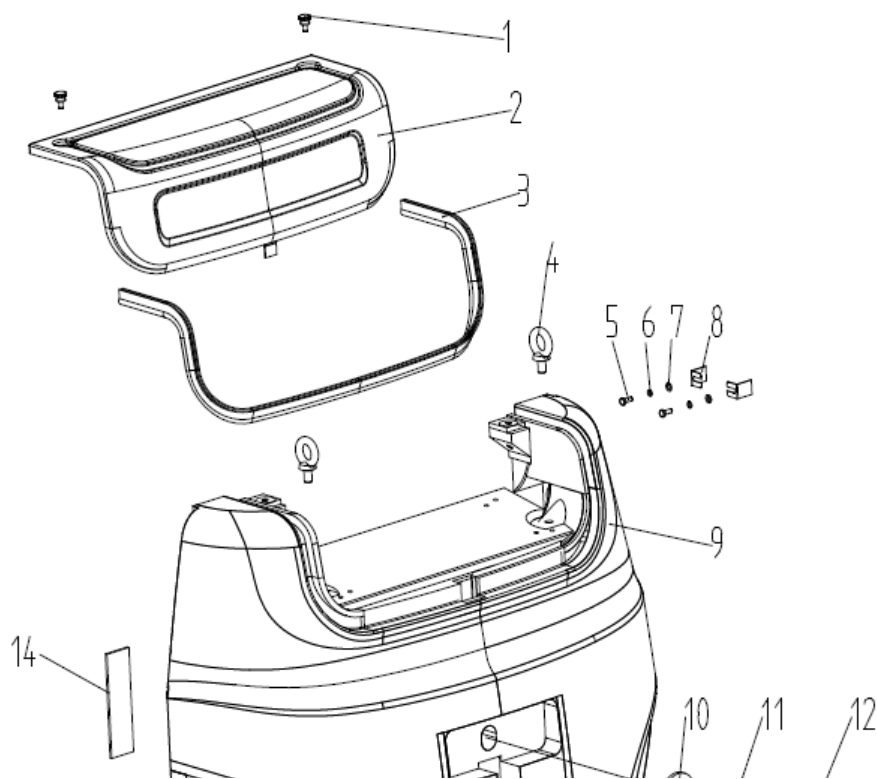
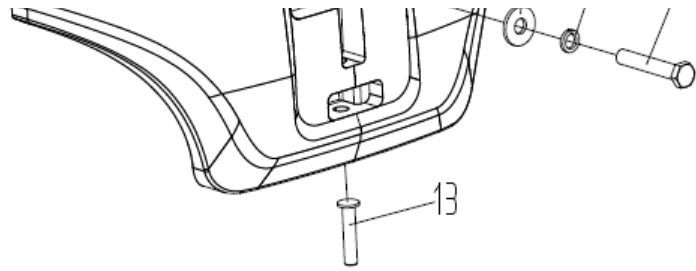



-	69004277	GB/T5782-M30*220-8.8J	Bolt M30×220	1	FBA35-JZ
13	69000266	M2576300004	Traction pin	1	
14	69064709	A25763-00003	Seal strip	2	用69017790剪

图27/Fig. 27

平衡重/ COUNTER WEIGHT

FBA15/18-JZ

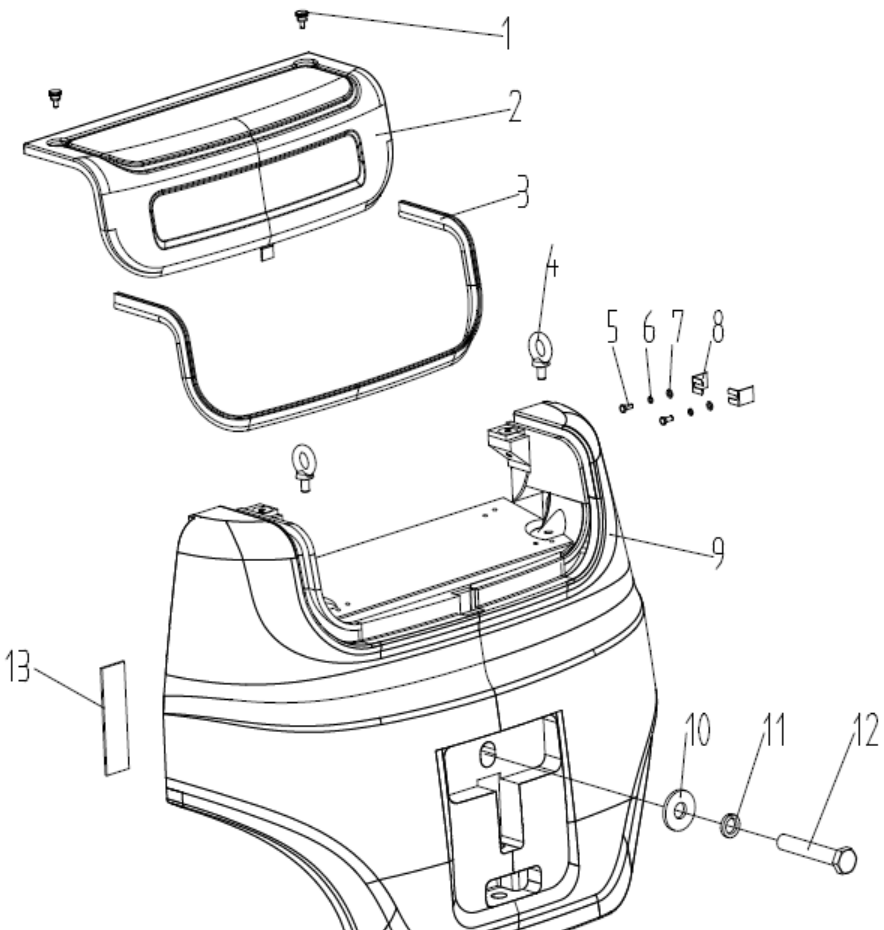

序号	物料号	代号	名称	数量	备注
Item No.	ID.	Part No.	Description	Q' ty	Remark
1	69023464	JB/T7274.4-1994	Star shaped handle M8×16	2	
2	69064705	A25763-01000	Electronic control board	1	
3	69059259	M30350-00002Z	Weatherstrip	2	用69059259剪
4	69002089	GB/T825-M16	Bolt M16	2	取消
5	69000198	GB/T5783-M8*20-8.8J	Bolt M8×20	4	
6	69000062	GB/T93-8	Washer 8	4	
7	69000259	GB/T97.1-8	Washer 8	4	
8	69015140	M3036300006-1mm	Adjusting washer-1mm	2-4	
	69015141	M3036300006-2mm	Adjusting washer-2mm	2-4	
9	69101707	A15763-00001-MRed	Counter weight-Mred	1	FBA15-JZ
-	69108230	A18763-00001-Mred	Counter weight-Mred	1	FBA18-JZ
10	69005115	M3036300004	Flat washer	1	
11	69000058	GB/T93-30	Washer 30	1	
12	69005957	GB/T5782-M30*180-8.8J	Bolt M30×180	1	FBA15/18-JZ 20191018停用
-	69003061	GB/T5782-M30*120-8.8J	Bolt M30×150	1	FBA15/18-JZ 20191018开始使用
13	69064709	A25763-00003	Seal strip	2	用69017790剪



图28/Fig. 28

仪表架及机罩安装/ DISPLAY BRACKET AND HOOD INSTALLATION

FBA15/18/20/25/30/35-JZ

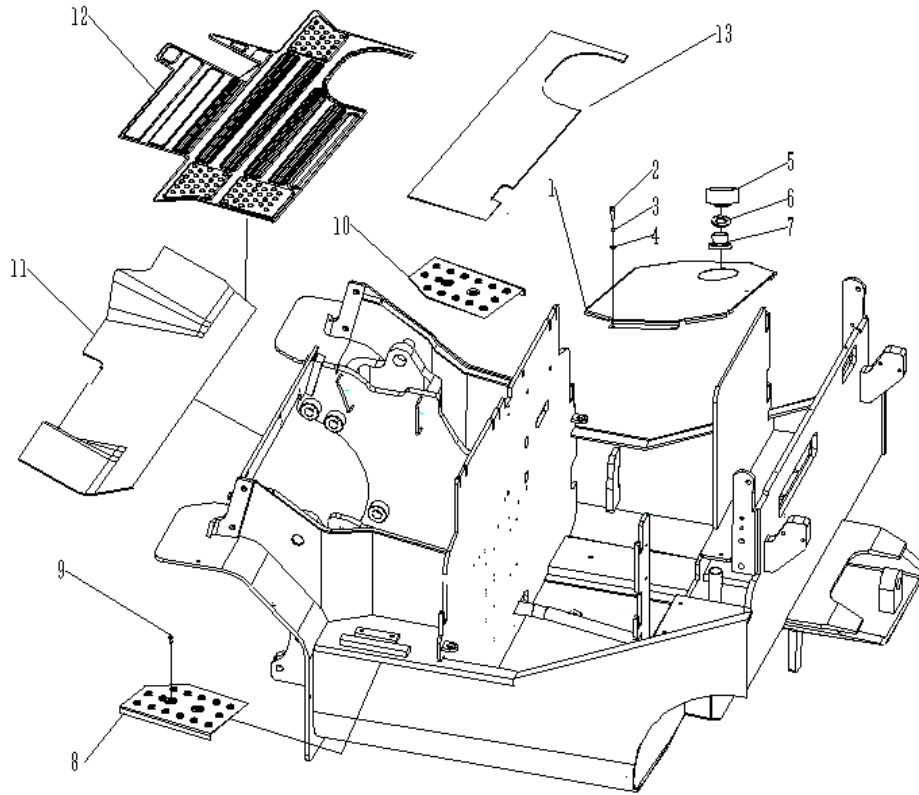

序号	物料号	代号	名称	数量	备注
Item No.	ID.	Part No.	Description	Q'ty	Remark
1	69067453	A30764-00001	Shield	1	FBA30/35-JZ
30	69000189	GB/T5783-M6*12-8.8J	Bolt M6×12	4	
3	69000060	GB/T93-6	Washer 6	4	
2	69000258	GB/T97.1-6	Washer 6	4	
5	69064749	A25764-00011	Cup	1	
6	69000357	JB/T982-20	Washer 20	1	
7	69064790	A25764-00012	Bolt	1	
8	69064980	A25764-00016	Left anti synovial membrane	1	FBA20/25/30/35-JZ
-	69133200	A15764-00003A	Left anti synovial membrane	1	FBA15/18-JZ 20190709
9	69017609	GB/T70.3-M8*16-10.9J	Bolt M8×16	4	
10	69064772	A25764-00008	Right synovial membrane	1	FBA20/25/30/35-JZ
-	69133201	A15764-00004A	Right synovial membrane	1	FBA15/18-JZ 20190709
11	69086323	A25764-01000-1	Front floor board	1	
12	69064740	A25764-00007	Rubber floor	1	FBA20/25/30/35-JZ
-	69064755	A15764-00001	Rubber floor	1	FBA15/18-JZ
13	69086324	A25764-05000-2	Rear floor board	1	FBA20/25/30/35-JZ
-	69086322	A15764-01000-1	Rear floor board	1	FBA15/18-JZ

图28/Fig. 28

仪表架及机罩安装/ DISPLAY BRACKET AND HOOD INSTALLATION

FBA15/18/20/25/30/35-JZ

序号	物料号	代号	名称	数量	备注
----	-----	----	----	----	----

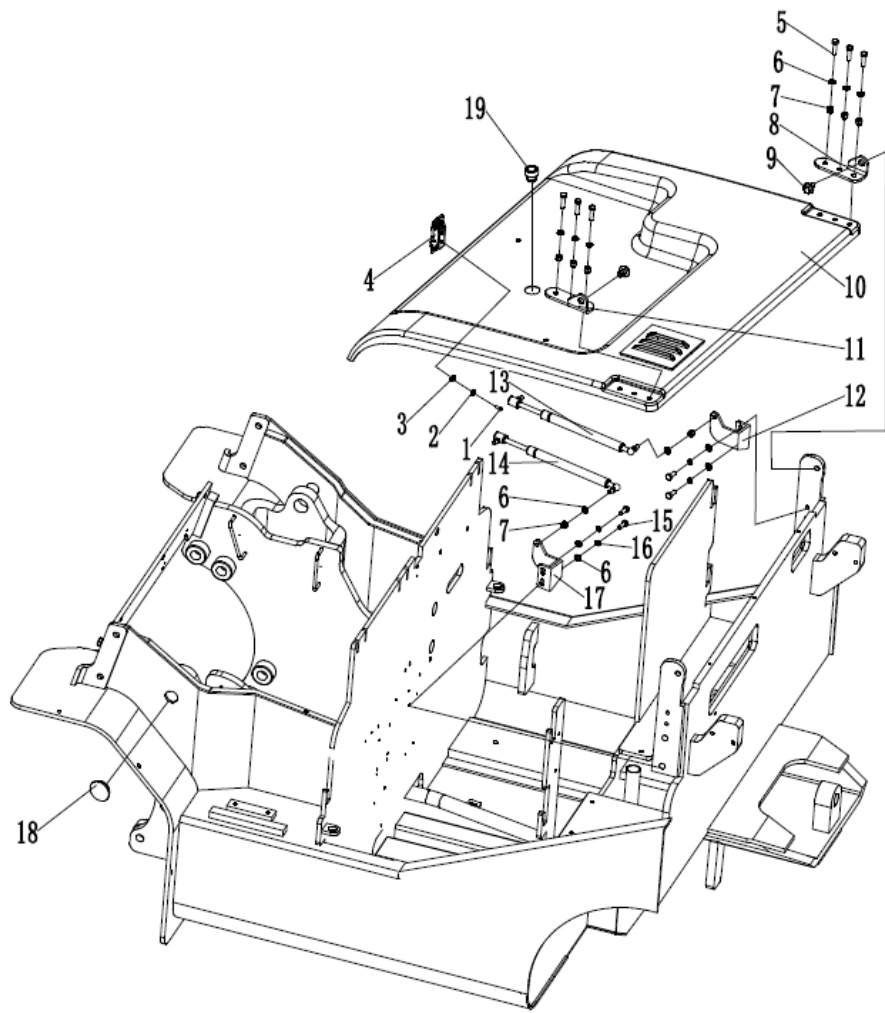

Item No.	ID.	Part No.	Description	Q' ty	Remark
1	69007977	GB/T818-M5*12-4. 8J	Bolt M5×12	2	
2	69000257	GB/T97. 1-5	Washer 5	2	
3	69000059	GB/T93-5	Washer 5	2	
4	69001716	M3036410000	Latch	1	
5	69000200	GB/T5783-M8*25-8. 8J	Bolt M8×25	6	
6	69000259	GB/T97. 1-8	Washer 8	12	
7	69000292	GB/T889. 1-M8-8J	Nut M8	8	
8	69001714	M2576400010	Lower cover	1	
9	69003537	M2576400012	Bolt	2	
10	69064979	A30764-02000	Cell cover	1	FBA30/35-JZ 20181215停用
-	69119075	A30764-02000A	Cell cover	1	FBA30/35-JZ 20181215开始使用
-	69064744	A25764-03000	Cell cover	1	FBA20/25-JZ 20181215停用
-	69119074	A25764-03000A	Cell cover	1	FBA20/25-JZ 20181215开始使用
-	69064757	A15764-02000	Cell cover	1	FBA15/18-JZ 20190806停用
-	69134514	A15764-02000B	Cell cover	1	FBA15/18-JZ 20190806开始使用
11	69001713	M2576400009	Left hinge	1	
12	69044007	M2576400008	Bracket	1	
13	69019026	M3076407000	Gas spring	1	FBA30/35-JZ 2190806停用
-	69134530	M3076407000A	Gas spring	1	FBA30/35-JZ 20190806开始使用
-	69003359	M2576406000	Gas spring	1	FBA20/25-JZ 2190806停用
-	69134526	M2576406000A	Gas spring	1	FBA20/25-JZ 2190806开始使用
-	69001780	M1576407000	Gas spring	1	FBA15/18-JZ 2190806停用
-	69134524	M1576407000A	Gas spring	1	FBA15/18-JZ 2190806开始使用

图28/ Fig. 28

仪表架及机罩安装/ DISPLAY BRACKET AND HOOD INSTALLATION

FBA15/18/20/25/30/35-JZ

序号	物料号	代号	名称	数量	备注
Item No.	ID.	Part No.	Description	Q' ty	Remark
14	69087412	A30764-04000	Gas spring	1	FBA30/35-JZ 20190806停用
-	69134529	A30764-04000A	Gas spring	1	FBA30/35-JZ 20190806开始使用

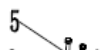

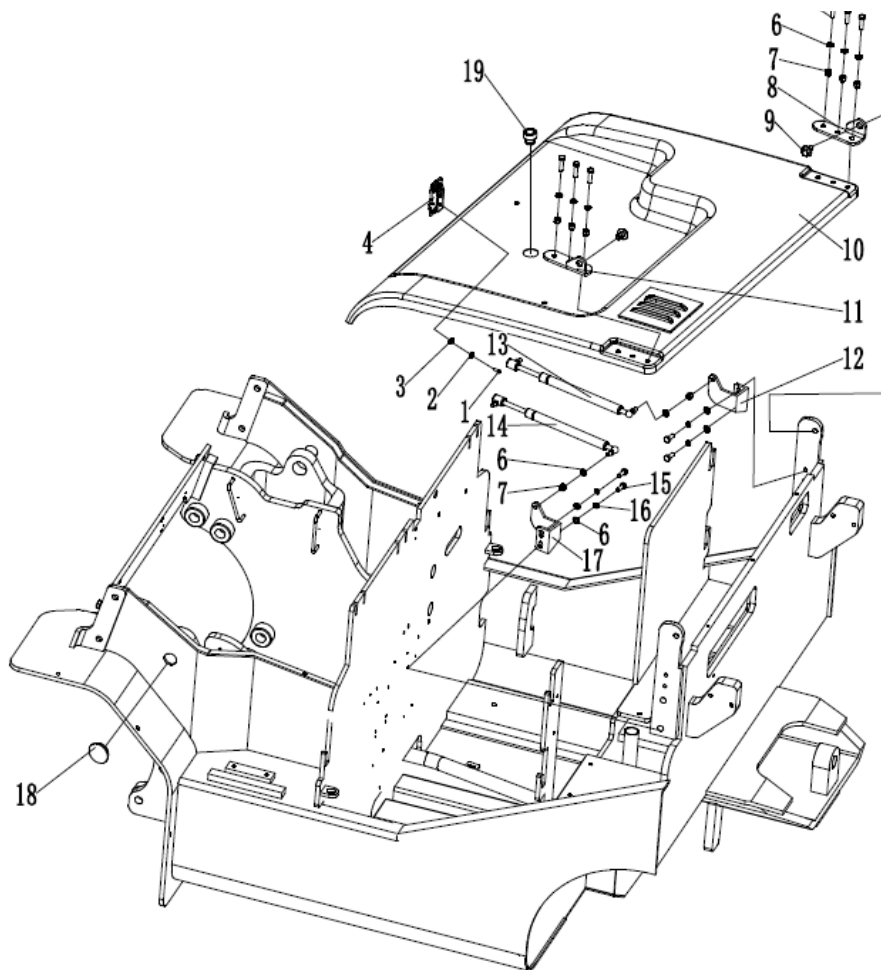

-	69087413	A25764-06000	Gas spring	1	FBA20/25-JZ 20190806停用
-	69134525	A25764-06000A	Gas spring	1	FBA20/25-JZ 20190806开始使用
-	69087414	A15764-05000	Gas spring	1	FBA15/18-JZ 20190806停用
-	69134523	A15764-05000A	Gas spring	1	FBA15/18-JZ 20190806开始使用
15	69000198	GB/T5783-M8*20-8. 8J	Bolt M8×20	4	
16	69000062	GB/T93-8	Washer 8	4	
17	69001790	M2576400007	Bracket	1	
18	69001764	M3036400007	Rubber stopper	2	
19	69121327	A25764-00018	Rubber stopper	1	

图28/Fig. 28 仪表架及机罩安装/ DISPLAY BRACKET AND HOOD INSTALLATION

FBA15/18/20/25/30/35-JZ

序号 Item No.	物料号 ID.	代号 Part No.	名称 Description	数量 Q'ty	备注 Remark
1	69001692	MS1676400005	Rubber pad	3	FBA15/18-JZ 20190806停用
2	69101733	A30764-03000-MRed	Left plate-MRed	1	FBA30/35-JZ
-	69101724	A25764-04000-Mred	Left plate-MRed	1	FBA20/25-JZ
-	69101712	A15764-04000-Mred	Left plate-MRed	1	FBA15/18-JZ
3	69101732	A30764-01000-Mred	Right side plate-Mred	1	FBA30/35-JZ



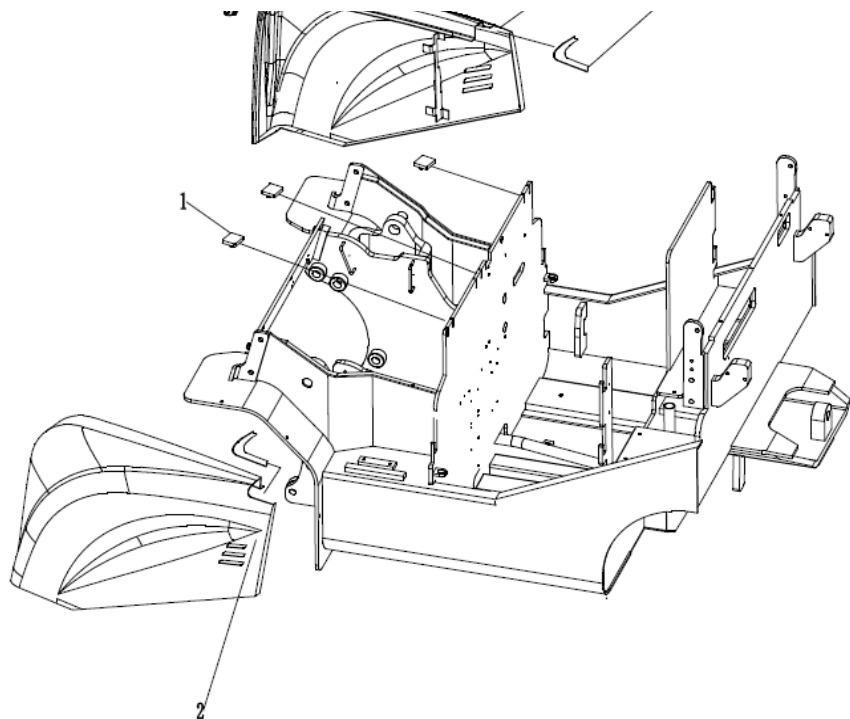

-	69101723	A25764-02000-Mred	Right side plate-Mred	1	FBA20/25-JZ
-	69101711	A15764-03000-Mred	Right side plate-Mred	1	FBA15/18-JZ
4	69023464	JB/T7274. 4-1994	Star shaped handle M8×16	2	
5	69140726	A25764-00020	Sealing strip	2	

图29/Fig. 29 座椅及安装/ SEAT ASS'Y

FBA15/18/20/25/30/35-JZ



序号	物料号	代号	名称	数量	
Item No.	ID.	Part No.	Description	Q' ty	
1	69018852	M2576801000-Y2	Seat	1	
2	69000203	GB/T5783-M8*30-8. 8J	Bolt M8×30	4	
3	69001890	M2576800001	Seat rubber pad	4	
4	69000259	GB/T97. 1-8	Washer 8	4	
5	69000292	GB/T889. 1-M8-8J	Nut M8	4	





图30/Fig. 30 多路阀换向操纵（二联） / MULTI-WAY VALVE CONTROL (TWO-THROW)

FBA15/18/20/25/30/35-JZ

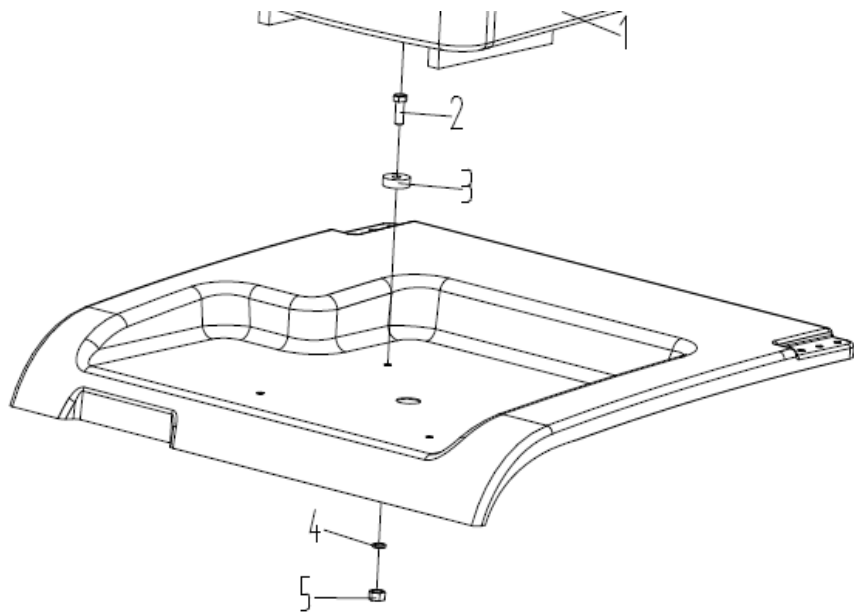
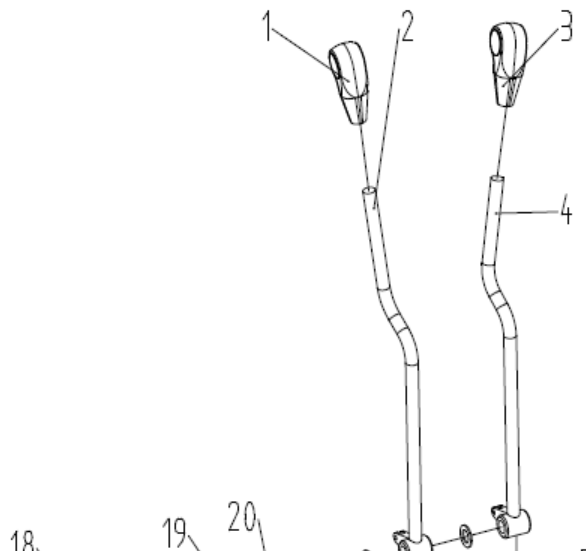

序号	物料号	代号	名称	数量	
Item No.	ID.	Part No.	Description	Q' ty	
1	69010624	M2577400005	Tilt handle	1	
2	69078510	A25774-04000-L	Multi valve control lever II	1	
3	69010625	M2577400004	Lift handle	1	
4	69078509	A25774-03000-L	Multi valve control lever I	1	
5	69003105	M2577400002	Connecting rod	4	
6	69001522	M2577400008	Sheath	4	
7	69039526	GB/T882-Φ6*18	Pin shaft Φ6×18	8	
8	69000088	GB/T91-2*12	Cotter pin 2×12	8	
9	69039526	GB/T882-Φ6*18	Bolt M6×16	2	
10	69064793	A25774-01000	Multi valve cover	1	
11	69000189	GB/T5783-M6*12-8.8J	Bolt M6×12	5	

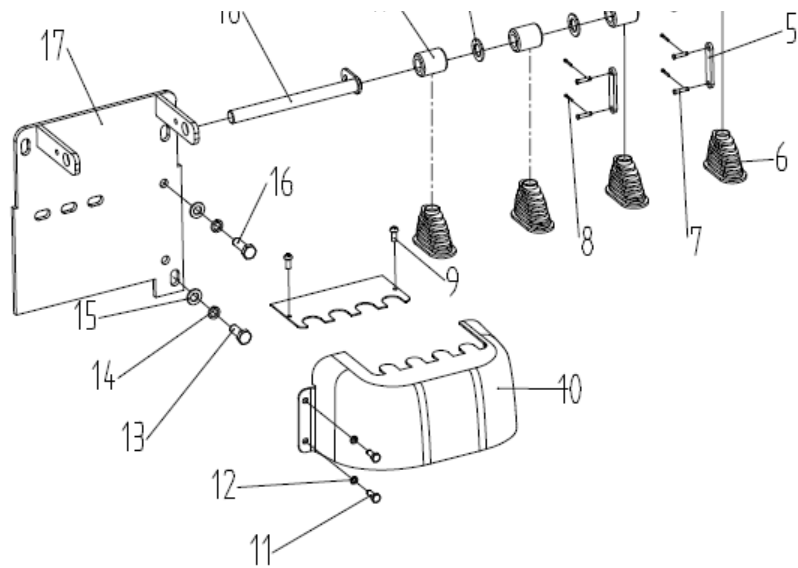



12	69000060	GB/T93-6	Washer 6	5	
13	69000123	GB/T5783-M10*20-8.8J	Bolt M10×20	3	
14	69000250	GB/T97.1-10	Washer 10	6	
15	69000053	GB/T93-10	Washer 10	6	
16	69000116	GB/T5786-M10*1.25*30-8.8J	Bolt M10×1.25×30	3	
17	69064811	A25774-02000	Seat	1	
18	69001621	M2577403000	Pin shaft	1	
19	69006760	M2577400001	Handle sleeve	1	
20	69001625	M2577400003 (1MM)	Bushing-1mm	按需	
-	69011790	M2577400003 (2MM)	Bushing-2mm	按需	
-	69011791	M2577400003 (3MM)	Bushing-3mm	按需	

图31/Fig. 31

多路阀换向操纵（三联） / MULTI-WAY VALVE CONTROL (THREE-THROW)

FBA15/18/20/25/30/35-JZ

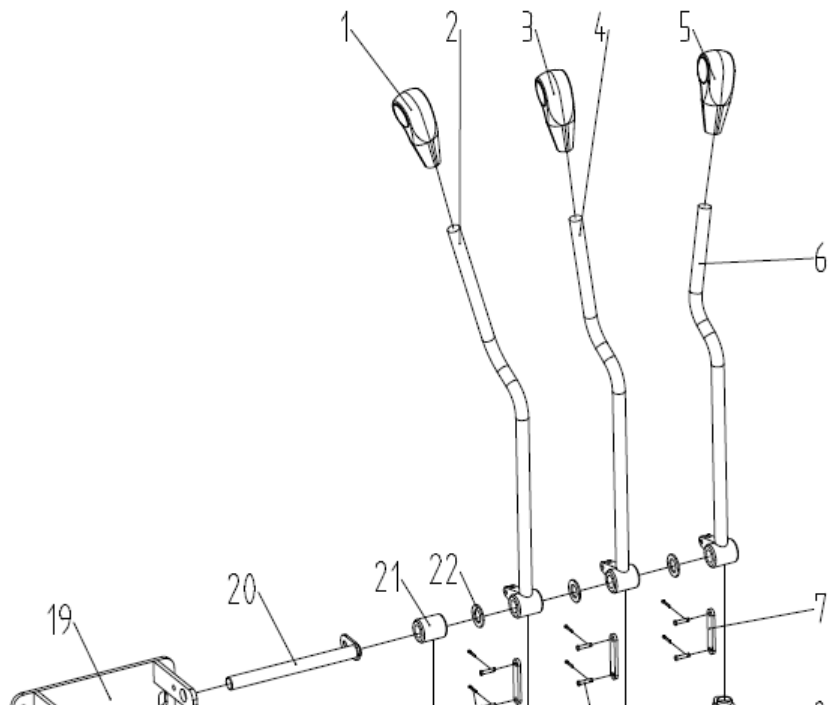

序号	物料号	代号	名称	数量	备注
Item No.	ID.	Part No.	Description	Q'ty	Remark
1	69088905	M2577400006	Handle	1	
2	69078511	A25774-05000-L	Multi valve control lever III	1	
3	69010624	M2577400005	Tilt handle	1	
4	69078510	A25774-04000-L	Multi valve control lever II	1	
5	69010625	M2577400004	Lift handle	1	
6	69078509	A25774-03000-L	Multi valve control lever I	1	
7	69003105	M2577400002	Connecting rod	4	
8	69001522	M2577400008	Sheath	4	
9	69039526	GB/T882-Φ6*18	Pin Φ6×18	8	
10	69000088	GB/T91-2*12	Pin 2×12	8	
11	69011317	GB/T818-M6*16-4.8J	Bolt M6×16	2	
12	69064793	A25774-01000	Multi valve cover	1	
13	69000189	GB/T5783-M6*12-8.8J	Bolt M6×12	5	
14	69000060	GB/T93-6	Washer 6	5	





图32/Fig. 32

多路阀换向操纵（四联） / MULTI-WAY VALVE CONTROL (FOUR-THROW)

FBA15/18/20/25/30/35-JZ



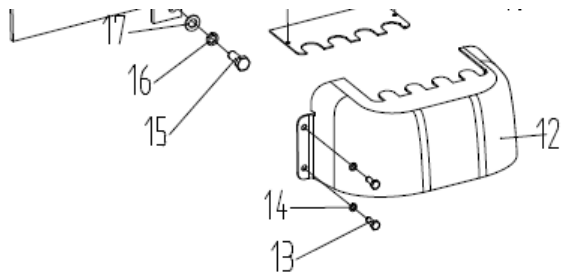
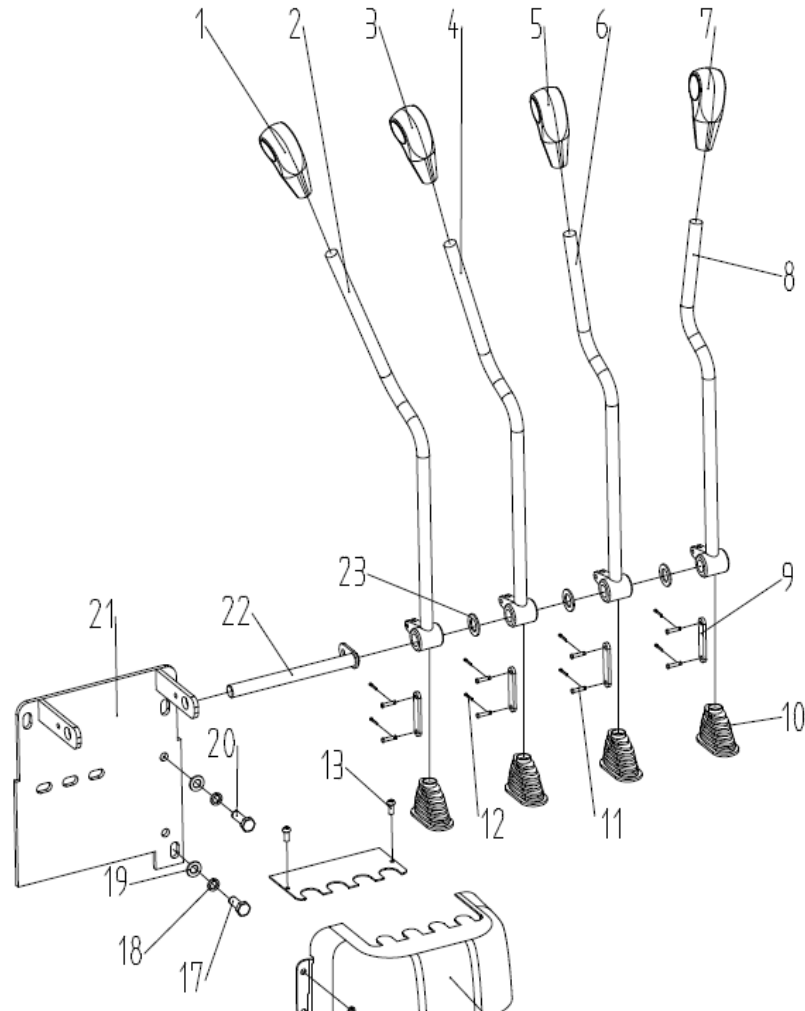

序号	物料号	代号	名称	数量	备注
Item No.	ID.	Part No.	Description	Q'ty	Remark
1	69011190	M2577400007	Unlabelled handle	1	
2	69078512	A25774-06000-L	Multi valve control lever IV	1	
3	69088905	M2577400006	Handle	1	
4	69078511	A25774-05000-L	Multi valve control lever III	1	
5	69010624	M2577400005	Tilt handle	1	
6	69078510	A25774-04000-L	Multi valve control lever II	1	
7	69010625	M2577400004	Lift handle	1	
8	69078509	A25774-03000-L	Multi valve control lever I	1	
9	69003105	M2577400002	Connecting rod	4	
10	69001522	M2577400008	Sheath	4	
11	69039526	GB/T882-Φ6*18	Pin Φ6×18	8	
12	69000088	GB/T91-2*12	Pin 2×12	8	
13	69011317	GB/T818-M6*16-4. 8J	Bolt M6×16	2	
14	69064793	A25774-01000	Multi valve cover	1	
15	69000189	GB/T5783-M6*12-8. 8J	Bolt M6×12	5	
16	69000060	GB/T93-6	Washer 6	5	
17	69000123	GB/T5783-M10*20-8. 8J	Bolt M10×20	3	
18	69000250	GB/T97. 1-10	Washer 10	6	
19	69000053	GB/T93-10	Washer 10	6	
20	69000116	GB/T5786-M10*1. 25*30-8. 8J	Bolt M10×1. 25×30	3	



图33/ Fig. 33

## 液压系统/ HYDRAULIC SYSTEM

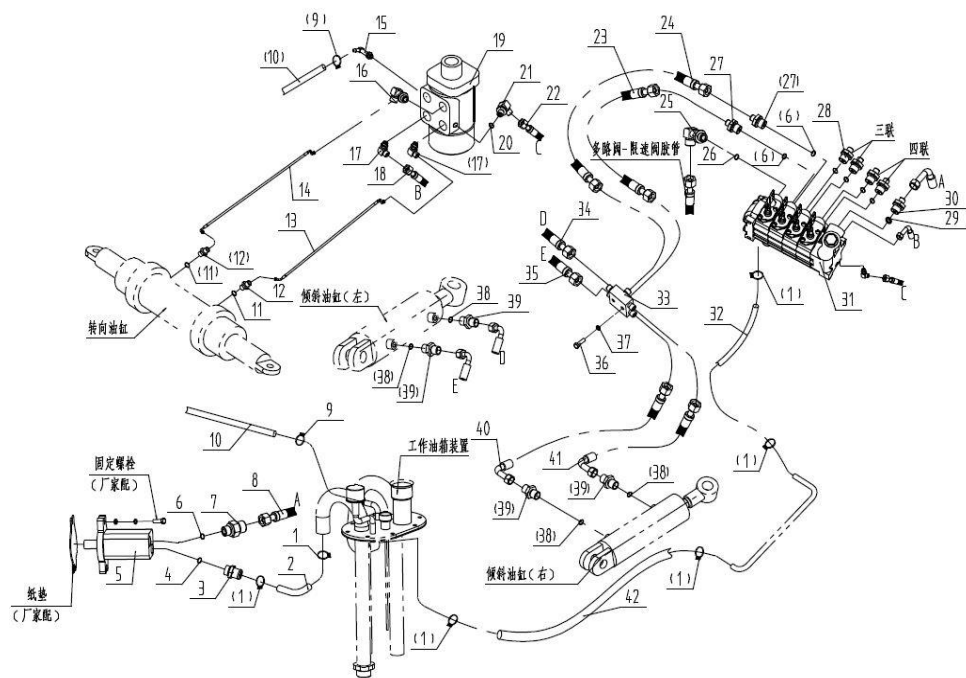
FBA15/18/20/25/30/35-JZ



序号	物料号	代号	名称	数量	备注
Item No.	ID	Part No.	Description	Q' ty	Remark
A	N/A	-	Hydraulic system	1	FBA15/18/20/25/30/35-JZ
1	69036889	JB/T8870-32-50	Hoop $\phi$ 32-50	6	
2	69064765	A25776-00001	Pump suction pipe	1	
3	69001280	M3037600005	Pump inlet joint	1	
4	69124133	GB1235-35*3.5-G	O-ring 35 $\times$ 3.5	1	
5	69002524	M1577601000-1	Gear pump	1	FBA15/18-JZ
-	69002525	M2577602000	Gear pump	1	FBA20/25/30/35-JZ
6	69124131	GB1235-22*2.4-G	O-ring 22 $\times$ 2.4	4	
7	69001421	M2577600003	Pump out oil joint		FBA15/18/20/25-JZ
-	69001278	M3037600004	Pump out oil joint	1	FBA30/35-JZ
8	69064760	A15776-00002	Oil inlet hose	1	FBA15/18-JZ
-	69064769	A25776-00002	Oil inlet hose	1	FBA20/25-JZ
-	69064792	A30776-00001	Oil inlet hose	1	FBA30/35-JZ
9	69022337	JB/T8870-20-32	Hoop $\phi$ 20-32	2	
10	69064847	A25776-00003	Steering gear return oil hose	1	FBA15/18/20/25-JZ
-	69127168	A30776-00002	Steering gear return oil hose	1	FBA30/35-JZ
11	69124124	GB1235-18*2.4-G	O-ring 18 $\times$ 2.4	2	
12	69003280	M3037600003	Steering cylinder joint	2	
13	69121317	A15776-00003A	Steering cylinder tubing I	1	FBA15/18-JZ
-	69121318	A25776-00004A	Steering cylinder tubing I	1	FBA20/25-JZ
-	69121324	A30776-00003A	Steering cylinder tubing I	1	FBA30/35-JZ
14	69121318	A25776-00004A	Steering cylinder tubing II	1	FBA15/18-JZ
-	69121319	A25776-00005A	Steering cylinder tubing II	1	FBA20/25-JZ

图33/ Fig. 33

## 液压系统/ HYDRAULIC SYSTEM

FBA15/18/20/25/30/35-JZ

序号	物料号	代号	名称	数量	备注
Item No.	ID	Part No.	Description	Q' ty	Remark

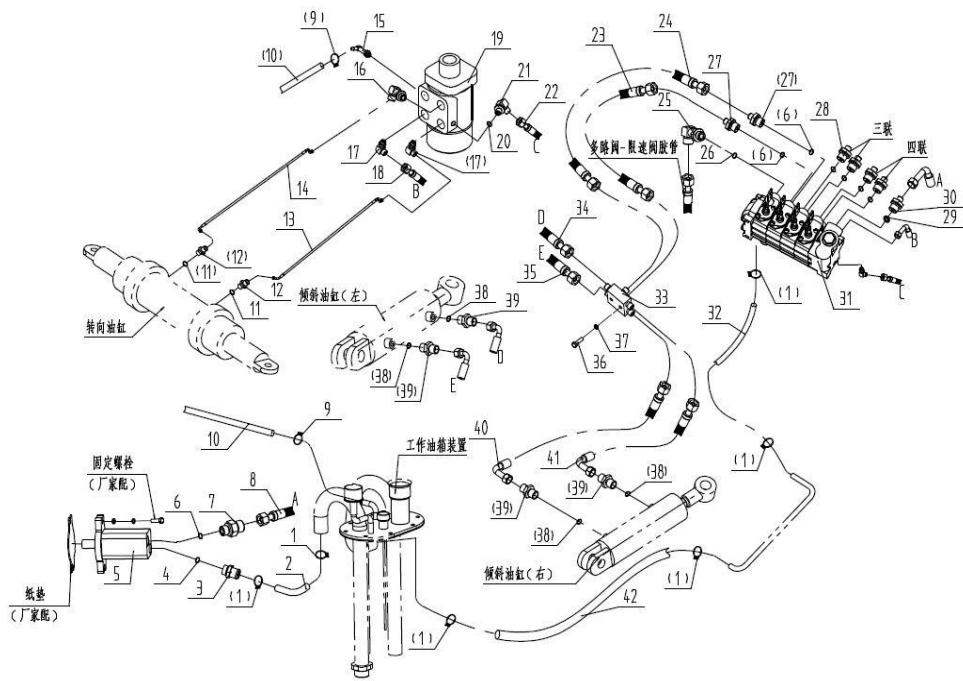

-	69121325	A30776-00004A	Steering cylinder tubing II	1	FBA30/35-JZ
15	69064778	A25776-01000	Steering gear return oil joint	1	
16	69064780	A25776-02000	Steering gear joint I	1	
17	69064781	A25776-03000	Steering gear joint II	2	
18	69064784	A25776-00006	Steering gear oil hose	1	
19	69093995	A15776-01000	Steering gear	1	FBA15/18-JZ (2019.7.22前)
-	69131541	U15776-01000	Steering gear	1	FBA15/18-JZ (2019.7.22后)
-	69093995	A15776-01000	Steering gear	1	FBA20/25-JZ (2019.7.22前)
-	69133062	A15776-01000A	Steering gear	1	FBA20/25-JZ (2019.7.22后)
-	69093993	25D76X-05000	Steering gear	1	FBA30/35-JZ (2019.7.22前)
-	69133063	25D76X-05000A	Steering gear	1	FBA30/35-JZ (2019.7.22后)
20	69023775	GB/T3452.1-8.5*2.65	O-ring 8.5×2.65	2	
21	69035500	25D76X-06000	Load sensing joint	2	
22	69064767	A15776-00005	Load sensing tube	1	FBA15/18-JZ
-	69064787	A25776-00007	Load sensing tube	1	FBA20/25/30/35-JZ
23	69064788	A25776-00008	Six way valve-Multi-way valve hose I	1	
24	69064789	A25776-00009	Six way valve-Multi-way valve hose II	1	
25	69003278	M3037601000	Multi valve lift cylinder connection	1	
26	69124142	GB/T3452.1-17*2.65-G	O-ring 17×2.65	1	
27	69001303	M3037600012	Multi valve and inclined cylinder joint	2	
28	69001504	M3037600021	Steering gear joint	2	三联
-	69001504	M3037600021	Steering gear joint	4	四联
29	69022457	GB/T1235-24*2.4	O-ring 24×2.4	1	

图33/Fig. 33

液压系统/ HYDRAULIC SYSTEM

FBA15/18/20/25/30/35-JZ	序号	物料号	代号	名称	数量	备注
	Item No.	ID	Part No.	Description	Q'ty	Remark
	30	69016767	30388-00003	Three way-three-way connector	1	FBA15/18/20/25-JZ
	-	69024858	45776-13000	Multi valve lift cylinder connection	1	FBA30/35-JZ
	31	69065480	A15776-02001	Multi-way valve	1	FBA15/18-JZ (二联)

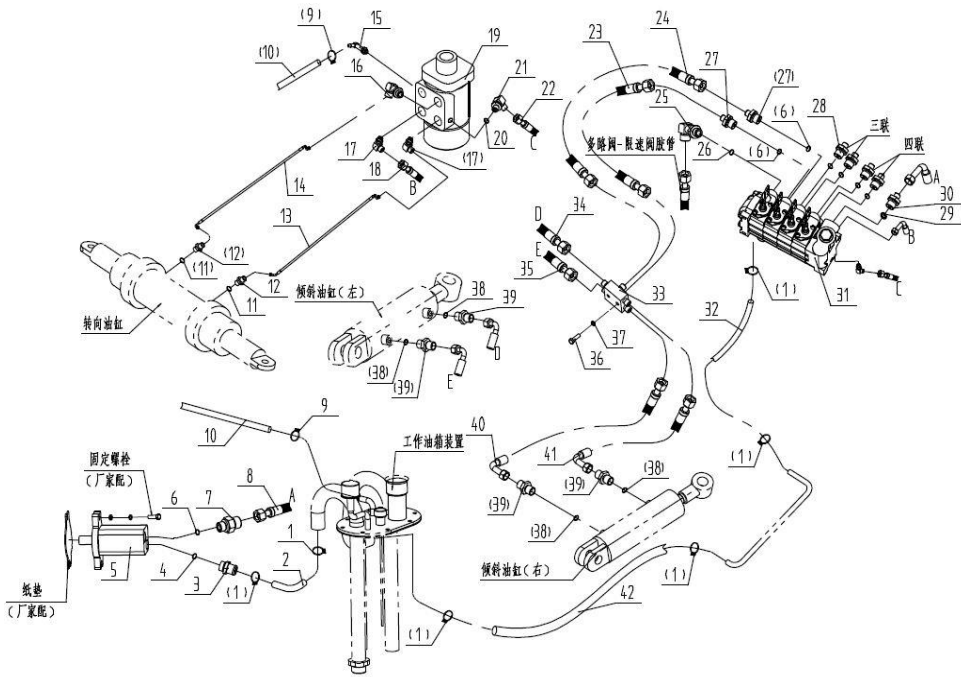

-	69065490	A15776-02002	Multi-way valve	1	FBA15/18-JZ (三联)
-	69065491	A15776-02003	Multi-way valve	1	FBA15/18-JZ (四联)
-	69064816	A25776-04001	Multi-way valve	1	FBA20/25/30/35-JZ (二联)
-	69064818	A25776-04002	Multiple unit valve	1	FBA20/25/30/35-JZ (三联)
-	69064819	A25776-04003	Multiple unit valve	1	FBA20/25/30/35-JZ (四联)
32	69064774	A15776-00006	Oil return line I	1	FBA15/18-JZ
-	69064802	A25776-00010	Oil return line I	1	FBA20/25/30/35-JZ
33	69001438	M2577601000	Six-way valve	1	
34	69064803	A15776-00009	Tilt tube I	1	FBA15/18-JZ
-	69121320	A25776-00011A	Tilt tube I	1	FBA20/25/30/35-JZ
35	69064805	A15776-00010	Tilt tube II	1	FBA15/18-JZ
-	69121321	A25776-00012A	Tilt tube II	1	FBA20/25/30/35-JZ
36	69000194	GB/T5783-M6*25-8.8J	Bolt M6×25	2	
37	69000060	GB/T93-6	Washer	2	
38	69123707	GB1235-11.2*2.4-G	O-ring 11.2×2.4	4	
39	69064806	A25776-00013	Tilt cylinder joint	4	
40	69121322	A25776-00014A	Tilt cylinder hose III	1	
41	69121323	A25776-00015A	Tilt cylinder hose IV	1	
42	69064770	A15776-00007	Oil return line II	1	FBA15/18-JZ
-	69064810	A25776-00016	Oil return line II	1	FBA20/25/30/35-JZ

图34/Fig. 34 工作油箱及安装/ FUEL TANK ASS'Y

FBA15/18/20/25/30-JZ					
序号	物料号	代号	名称	数量	备注
Item No.	ID.	Part No.	Description	Q'ty	Remark
A	69107885	A15775-01000-1	Oil tank ASS'Y	1	FBA15/18-JZ
B	69107884	A25775-01000-1	Oil tank ASS'Y	1	FBA20/25/30/35-JZ
1	69000085	GB/T96.1-8	Washer 8	1	
2	69138772	A25775-01002A	Magnet	1	

FBA15/18/20/25/30-JZ					
序号	物料号	代号	名称	数量	备注
Item No.	ID.	Part No.	Description	Q'ty	Remark
A	69107885	A15775-01000-1	Oil tank ASS'Y	1	FBA15/18-JZ
B	69107884	A25775-01000-1	Oil tank ASS'Y	1	FBA20/25/30/35-JZ
1	69000085	GB/T96.1-8	Washer 8	1	
2	69138772	A25775-01002A	Magnet	1	



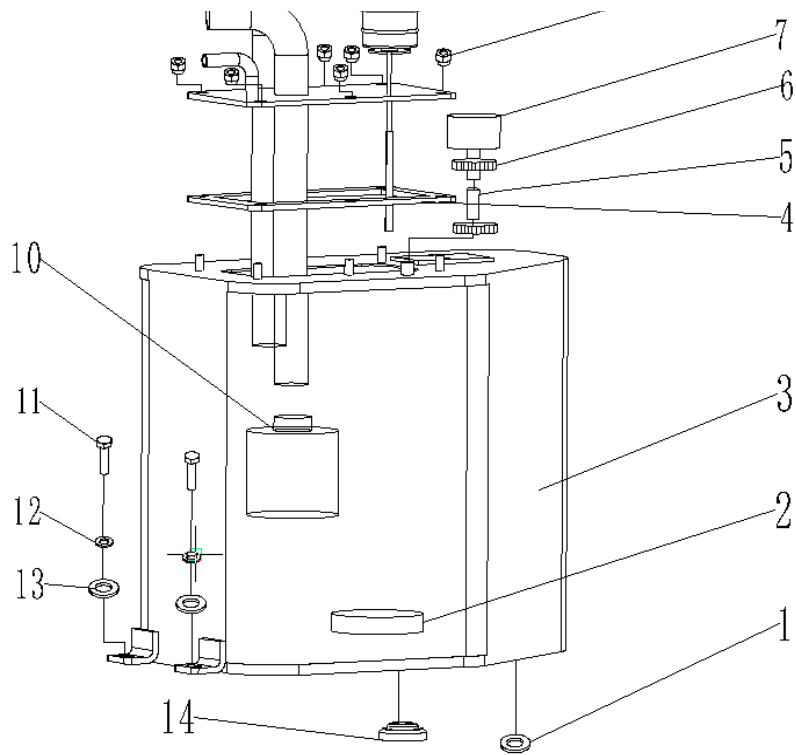

3	69138774	A15775-01100A	Oil tank	1	
-	69138775	A25775-01100A	Oil tank	1	
4	69138776	A25775-01004A	Gasket	1	
5	69127357	MS1677500002	Respirator hose	1	
6	69000052	JB/T8870-10-16	Hoop $\phi$ 10-16	2	
7	69097475	M2577500003A	Respirator	1	
8	69000111	GB/T6170-M8-8J	Nut M8	6	
9	69138778	A25775-01005A	Fuel tank cover	1	
10	69138773	A25775-01003A	Filter core	1	
11	69135248	GB/T5783-2000-M8*16	Bolt M8×16	3	
12	69000062	GB/T93-8	Washer 8	3	
13	69000259	GB/T97.1-8	Washer 8	3	
14	69138771	A25775-01001A	Drain plug	1	

图35/FIG. 35

货叉/FORK

FBA15/18-JZ



序号	物料号	代号	名称	数量	备注
Item No.	ID.	Part No.	Description	Q'ty	Remark
01	N/A	M1538003000	Fork ass'y	2	
02	69141827	M1538003001	Positioning pin	2	
03	69141828	M1538003002	Spring	2	
04	69136810	M3038003103	Handle	2	







图35FIG. 35 货叉/FORK

FBA15/18-JZ

货叉选用表 Fork optional parts

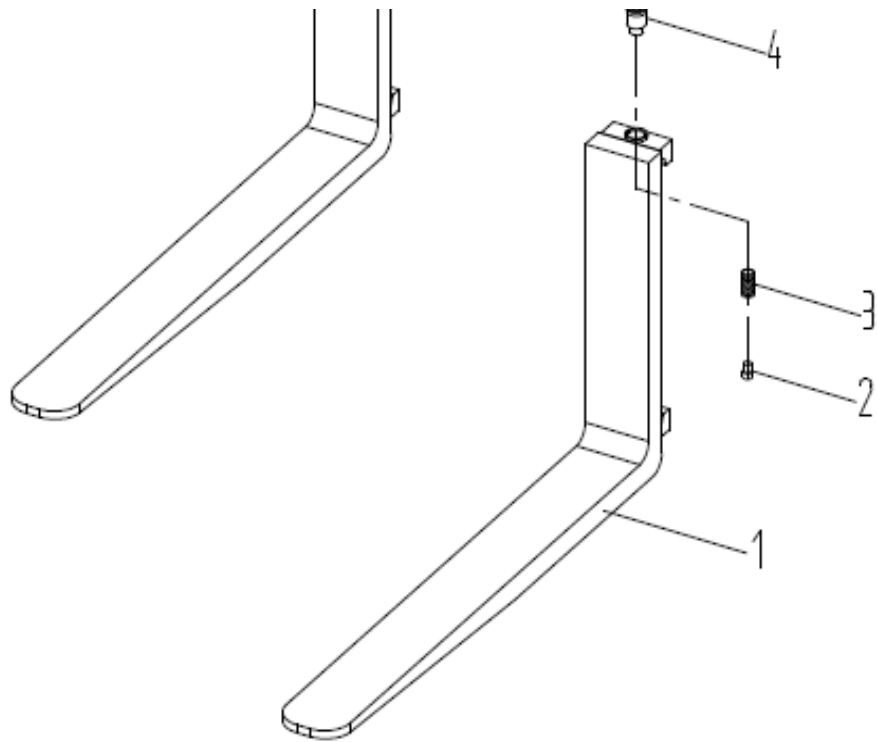
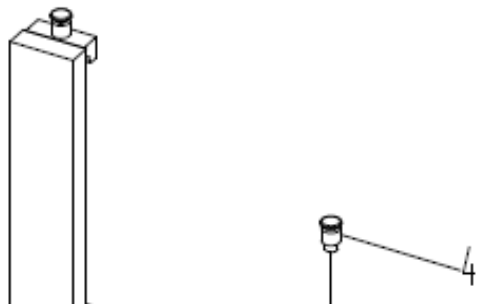
长度 LENGTH	物料号 ID.	货叉代号 PART NO. 1.5-1.8t	备注 Remark
920	69110608	M15380-HC-35*920-Black	标准
1070	69110617	M15380-HC-35*1070-Black	
1220	69110614	M15380-HC-35*1220-Black	
1370	69110631	M15380-HC-32*1370-Black	
1520	69110612	M15380-HC-35*1520-Black	
1670	69110611	M15380-HC-35*1670-Black	
1820	69110610	M15380-HC-35*1820-Black	

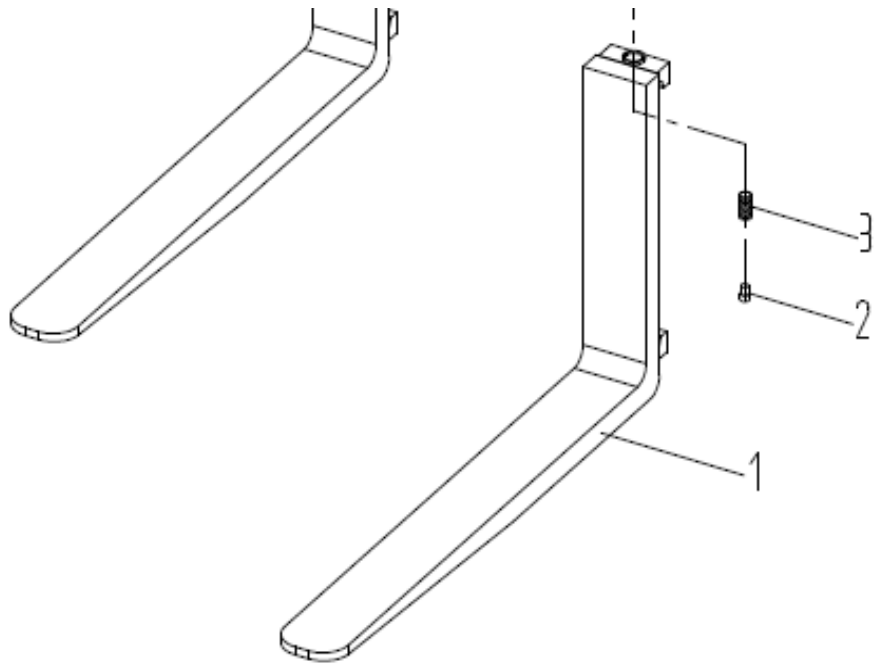



1970	69110609	M15380-HC-35*1970-Black		
2120	69110623	M15380-HC-35*2120-Black		
2300	69110621	M15380-HC-35*2300-Black		
2440	69110620	M15380-HC-35*2440-Black		

图36/FIG. 36

货叉/FORK

FBA20/25/30/35-JZ

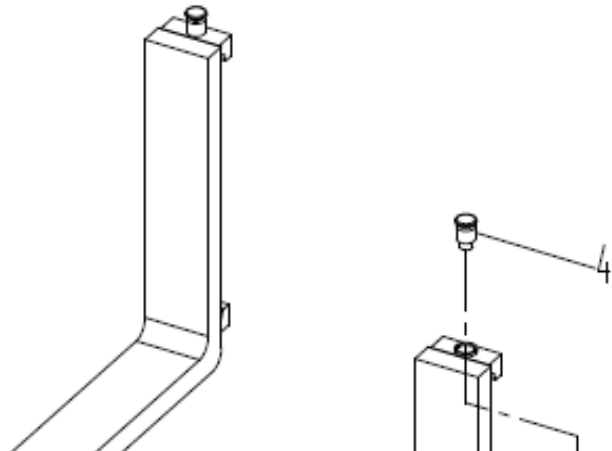

序号	物料号	代号	名称	数量	备注
Item No.	ID.	Part No.	Description	Q' ty	Remark
01	69136260	M2038003000	Fork ass'y	2	FBA20/25-JZ
-	N/A	M3038003000	Fork ass'y	2	FBA30-JZ
-	N/A	M3538002000	Fork ass'y	2	FBA35-JZ
02	69022108	M3038003101	Positioning pin	2	
03	69136807	M2038003102	Spring	2	FBA20/25-JZ
-	69136808	M3038003102	Spring	2	FBA30-JZ
-	69136809	M3538002102	Spring	2	FBA35-JZ
04	69136810	M3038003103	Handle	2	

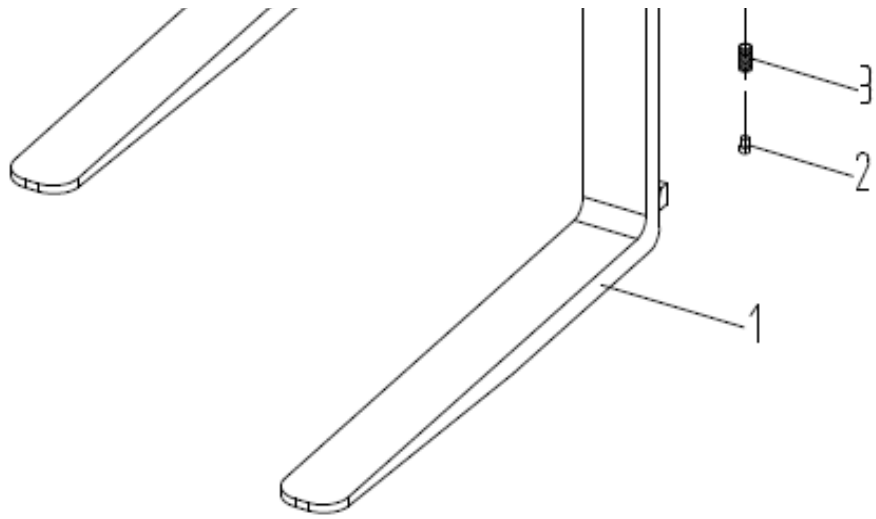

-					

图36/FIG. 36

货叉/FORK

FBA20/25/30/35-JZ

货叉选用表 Fork optional parts

长度LE NGTH	物料号	货叉代号 PART NO.		备注 Remark
	ID.	2t	ID.	
1070	69110782	M20380-HC-100*1070-Black	691106093	
1220	69110779	M20380-HC-100*1220-Black	69110648	
1370	69110778	M20380-HC-100*1370-Black	69110646	
1520	69110777	M20380-HC-100*1520-Black	69110645	
1670	69110776	M20380-HC-100*1670-Black	69110643	
1820	69110775	M20380-HC-100*1820-Black	69110642	
1970	69110774	M20380-HC-100*1970-Black	69110641	
2120	69110771	M20380-HC-100*2120-Black	69110639	
2300	69110769	M20380-HC-100*2300-Black	69110637	
2440	69110768	M20380-HC-100*2440-Black	69110636	







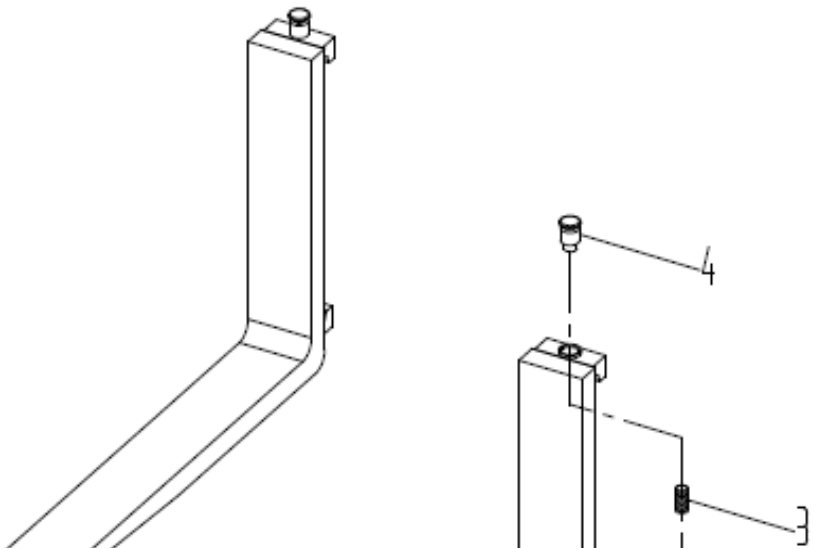

图39/FIG. 39

货叉架(三级全自由)/LIFT BRACKET (FULL FREE 3 STAGE MAST)

FBA15/18-JZ

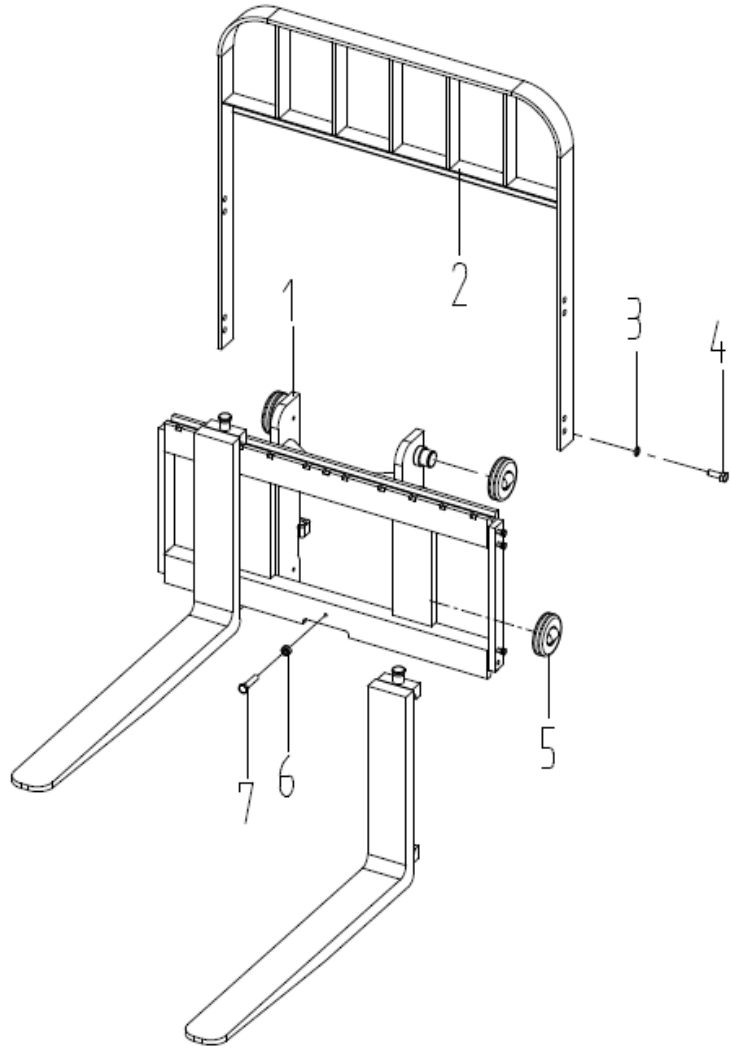

序号	物料号	代号	名称	数量	备注
Item No.	ID.	Part No.	Description	Q'ty	Remark
01	69116365	A15784-02000-Black	Fork carriage	1	
02	69112178	M1538002000-Black	Backrest	1	
03	69005111	GB/T93-14	Washer 14	8	
04	69000159	GB/T5786-M14*1.5*30-8.8J	Bolt M14×1.5×30	8	
05	69007470	15S02-02005	Combination roller 760211AT	4	140槽钢用
-	69085543	15S02-02005A	Combination roller 760211N3T	4	14C槽钢用
06	69000103	GB/T6170-M10-8J	Nut M10	1	
07	69000128	GB/T5783-M10*30-8.8J	Bolt M10×30	1	

图40/FIG. 40

货叉架(基本)/LIFT BRACKET (NORMAL MAST)

FBA20/25/30/35-JZ

序号	物料号	代号	名称	数量	备注
----	-----	----	----	----	----

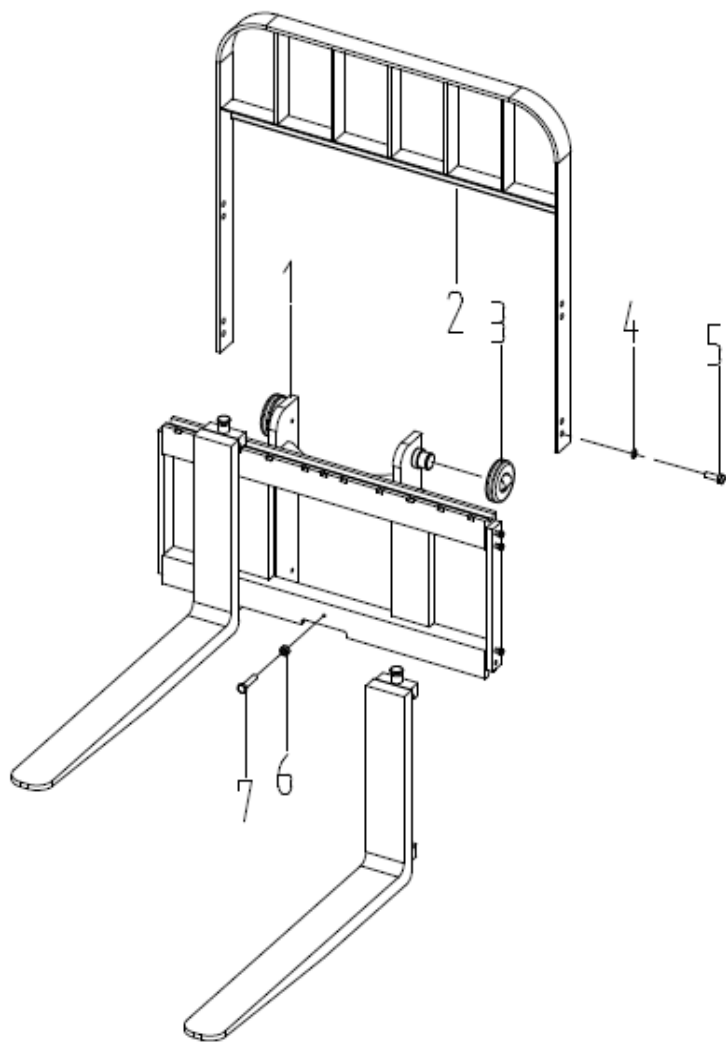

Item No.	ID.	Part No.	Description	Q'ty	Remark
01	69106967	A25780-02000-Black	Fork carriage	1	FBA20/25-JZ
-	69116361	A30780-02000-Black	Fork carriage	1	FBA30-JZ
-	69116358	A35780-01000-Black	Fork carriage	1	FBA35-JZ
02	69106077	20380A-02000-Black	Backrest	1	FBA20/25-JZ
-	69105746	30380A-02000-Black	Backrest	1	FBA30/35-JZ
03	69020211	A25780-06000	Combination roller 760211K1T	6	FBA20/25-JZ
-	69021690	M3038007000	Combination roller 760311NT	6	FBA30/35-JZ
04	69005111	GB/T93-14	Washer 14	8	
05	69000159	GB/T5786-M14*1.5*30-8.8J	Bolt M14×1.5×30	8	
06	69000103	GB/T6170-M10-8J	Nut M10	1	
07	69000128	GB/T5783-M10*30-8.8J	Bolt M10×30	1	

图41/FIG. 41 货叉架(二级全自由)/LIFT BRACKET (FULL FREE 2 STAGE MAST)

FBA20/25/30/35-JZ



序号	物料号	代号	名称	数量	备注
Item No.	ID.	Part No.	Description	Q'ty	Remark
01	69116363	A25782-02000-Black	Fork carriage	1	FBA20/25-JZ
-	69116360	A30782-02000-Black	Fork carriage	1	FBA30-JZ



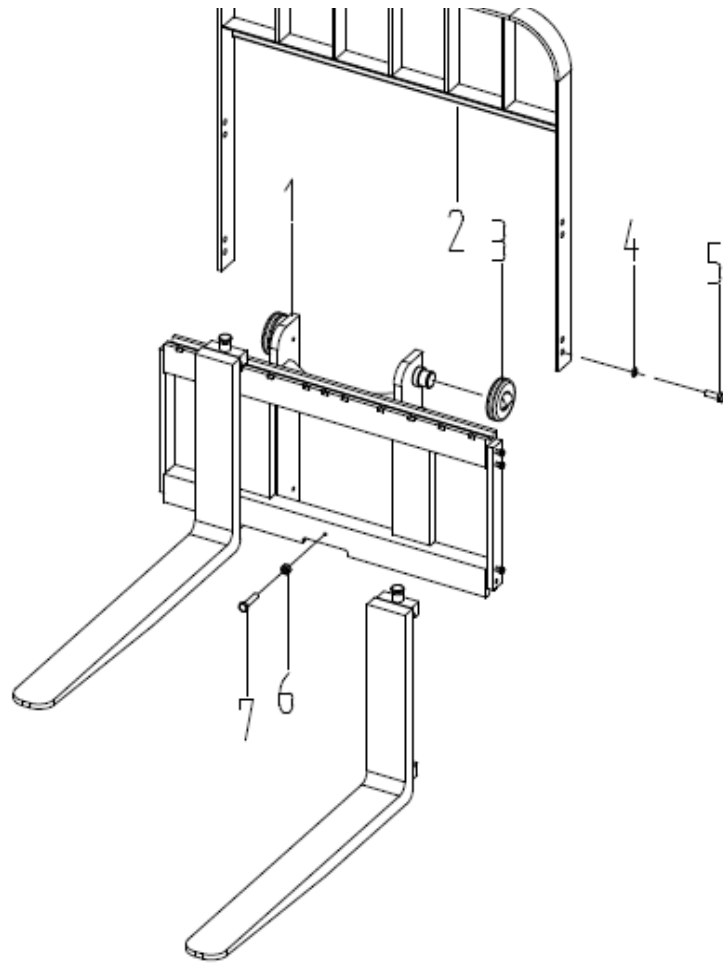

-	69116357	A35782-04000-Black	Fork carriage	1	FBA35-JZ
02	69106077	20380A-02000-Black	Backrest	1	FBA20/25-JZ
-	69105746	30380A-02000-Black	Backrest	1	FBA30/35-JZ
03	69020211	A25780-06000	Combination roller 760211KIT	6	FBA20/25-JZ
-	69021690	M3038007000	Combination roller 760311NT	6	FBA30/35-JZ
04	69005111	GB/T93-14	Washer 14	8	
05	69000159	GB/T5786-M14*1.5*30-8.8J	Bolt M14×1.5×30	8	
06	69000103	GB/T6170-M10-8J	Nut M10	1	
07	69000128	GB/T5783-M10*30-8.8J	Bolt M10×30	1	

图42/FIG. 42 货叉架(三级全自由)/LIFT BRACKET (FULL FREE 3 STAGE MAST)

FBA20/25/30/35-JZ

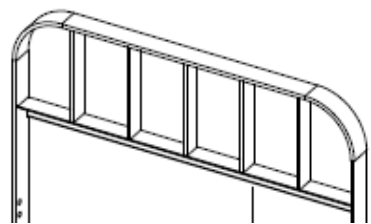

序号 Item No.	物料号 ID.	代号 Part No.	名称 Description	数量 Q'ty	备注 Remark
01	69116362	A25784-02000-Black	Fork carriage	1	FBA20/25-JZ
-	69116359	A30784-02000-Black	Fork carriage	1	FBA30-JZ
-	69116356	A35784-02000-Black	Fork carriage	1	FBA35-JZ
02	69106077	20380A-02000-Black	Backrest	1	FBA20/25-JZ
-	69105746	30380A-02000-Black	Backrest	1	FBA30/35-JZ

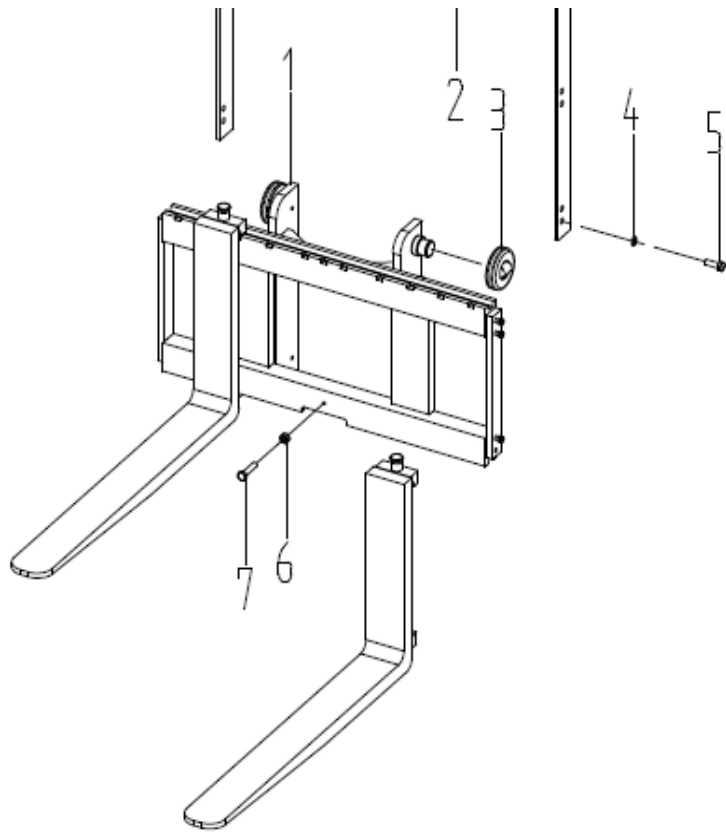

03	69020211	A25780-06000	Combination roller 760211KIT	6	FBA20/25-JZ
-	69021690	M3038007000	Combination roller 760311NT	6	FBA30/35-JZ
04	69005111	GB/T93-14	Washer 14	8	
05	69000159	GB/T5786-M14*1.5*30-8.8J	Bolt M14×1.5×30	8	
06	69000103	GB/T6170-M10-8J	Nut M10	1	
07	69000128	GB/T5783-M10*30-8.8J	Bolt M10×30	1	

图43/FIG. 43 门架(基本型) / MAST(NORMAL MAST)

FBA15/18-JZ

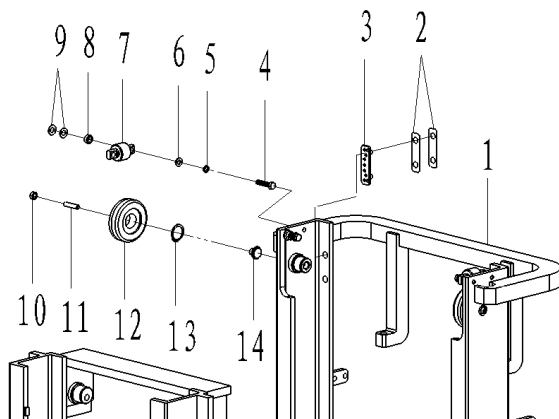

序号	物料号	代号	名称	数量	备注
Item No.	ID.	Part No.	Description	Q'ty	Remark
1	N/A	A15780-02000	Outer mast ass'y	1	140槽钢
-	N/A	A15780-02000A	Outer mast ass'y	1	14C槽钢
2	69009498	M3038000004/0.5	Adjusting shim set	AR	
3	69020280	M1538000003	Slipper	2	140槽钢用
-	69085545	M1538000003A	Slipper	2	14C槽钢用
4	69024917	GB/T5786-M10*1.25*45-8.8J	Bolt M10×1.25×45	4	
5	69000053	GB/T93-10	Washer 10	4	
6	69000250	GB/T97.1-10	Washer 10	4	

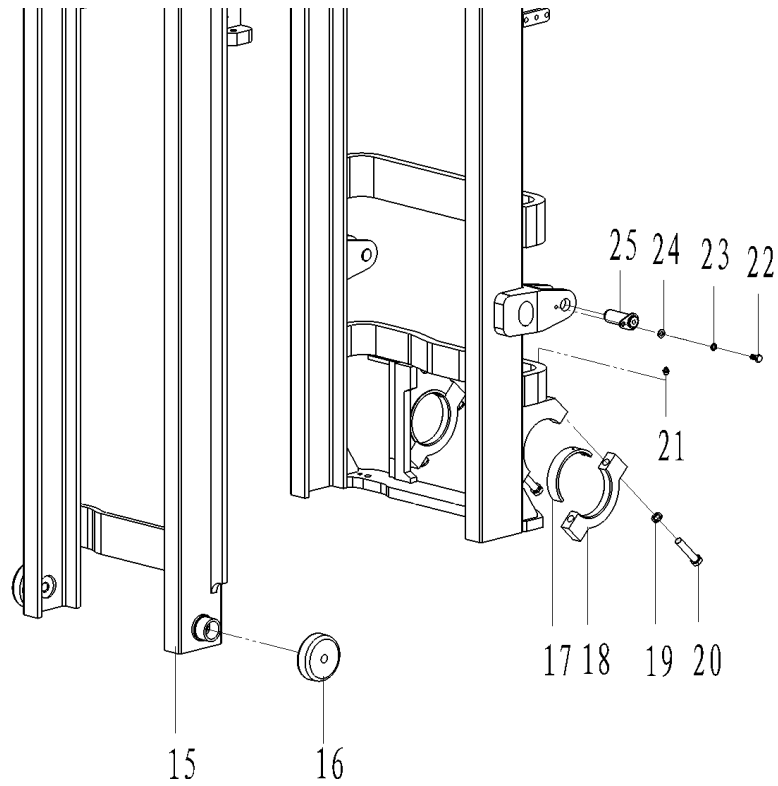

7	69005548	M1538012000	Side roller CN-2	2	
8	69068137	M3038000012/18	Washer	4	
9	69012066	M3038000006/0.5	Adjusting shim set II	4组	
10	69011485	GB/T6171-M10*1-8J	Nut M10×1	2	
11	69021681	GB/T79-M10*1*45	Screw M10×1×45	2	
12	69005550	M1538011000	Roller 180707K	2	
13	69005095	GB/T894.1-Φ35	Snap spring 35	2	
14	69012654	M3038000010	Adjusting shim	2	
15	N/A	M1538007000	Inner mast ass'y	1	140槽钢
-	N/A	M1538007000	Inner mast ass'y	1	14C槽钢
16	69007470	15S02-02005	Combination roller 760211AT	2	140槽钢用
-	69085543	15S02-02005A	Combination roller 760211N3T	2	14C槽钢用
17	69009371	M1538000002	Bearing liner	2	
18	69009487	M1538000001	Bearing cap	2	
19	69005111	GB/T93-14	Washer 14	4	
20	69003602	GB/T5785-M14*1.5*80-8.8J	Bolt M14×1.5×80	4	
21	69003941	JB/T7940.1-M10*1	Nipple M10×1	2	

图43/FIG. 43

门架(基本型) / MAST(NORMAL MAST)

FBA15/18-JZ

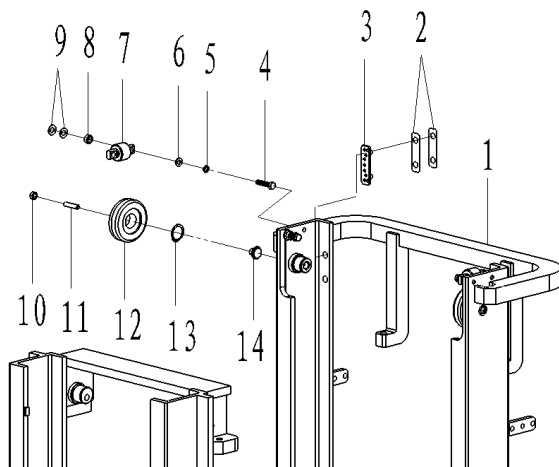

序号	物料号	代号	名称	数量	备注
Item No.	ID.	Part No.	Description	Q'ty	Remark
22	69000123	GB/T5783-M10*20-8.8J	Bolt M10×20	2	
23	69000053	GB/T93-10	Washer 10	2	
24	69000250	GB/T97.1-10	Washer 10	2	
25	69070207	A25780-07000	Pin shaft	2	





图43/FIG. 43 门架(基本型) / MAST (NORMAL MAST)

FBA15/18-JZ

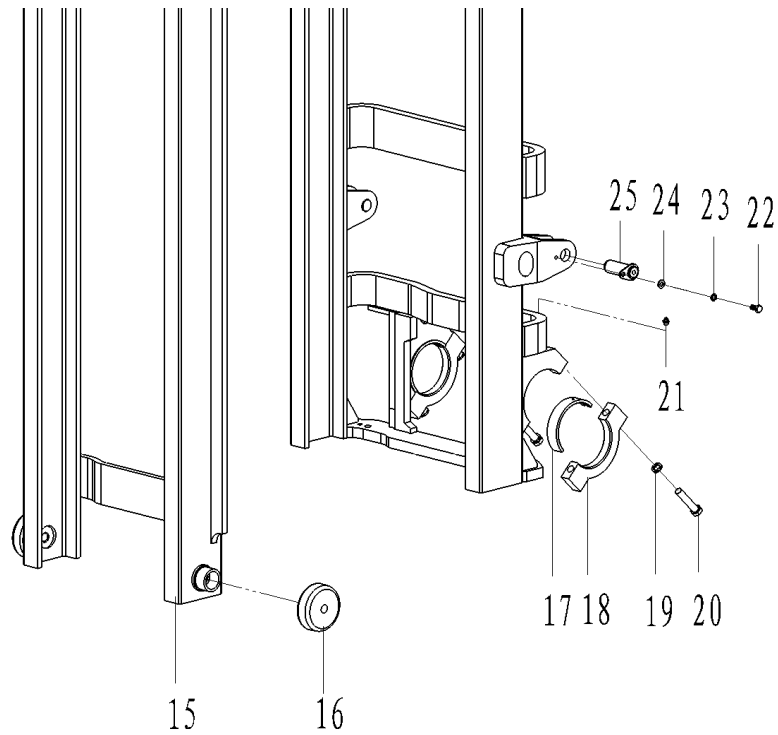
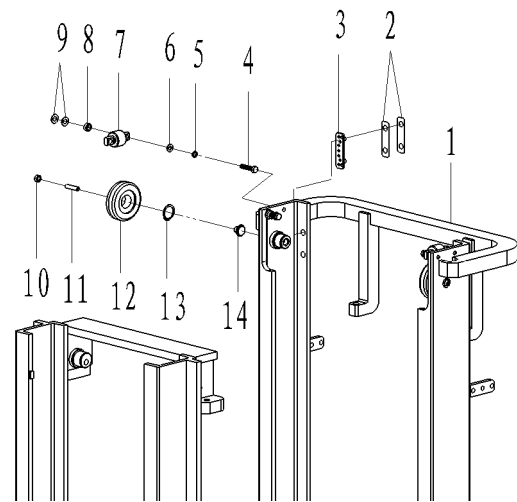

门架选用表(140槽钢) Mast Optional Parts

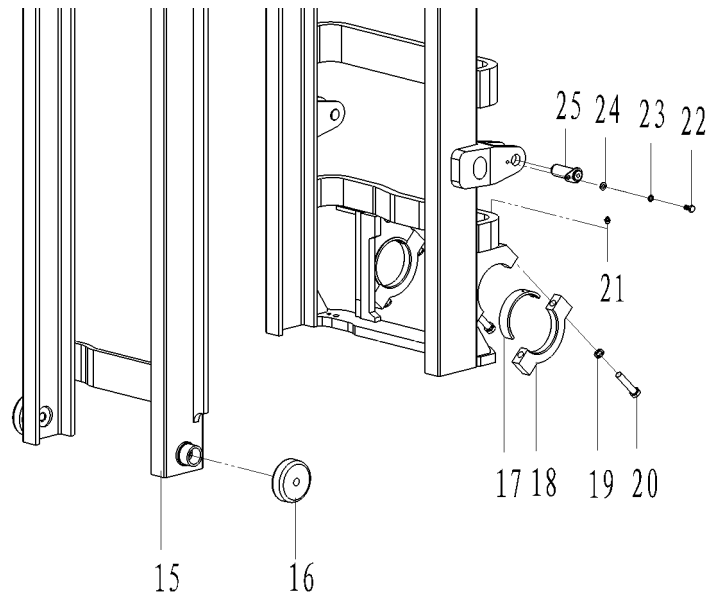
起升高度 Lifting Height	物料号	外门架总成 Outer mast	物料号	备注 Remark
	ID.		ID.	
3000	69102117	A15780-02000A-3.0M-Black	69102028	
3300	69102118	A15780-02000A-3.3M-Black	69102029	
3500	69102119	A15780-02000A-3.5M-Black	69102030	
3700	69102120	A15780-02000A-3.7M-Black	69102031	
4000	69102121	A15780-02000A-4.0M-Black	69102032	
4250	69102122	A15780-02000A-4.25M-Black	69102034	
4500	69102123	A15780-02000A-4.5M-Black	69102035	
4750	69102124	A15780-02000A-4.75M-Black	69102036	
5000	69102125	A15780-02000A-5.0M-Black	69109001	



5500	69102126	A15780-02000A-5.5M-Black	69102038	
6000	69102127	A15780-02000A-6.0M-Black	69102039	

图43/FIG. 43

门架(基本型) / MAST (NORMAL MAST)

FBA15/18-JZ

门架选用表(14C槽钢) Mast Optional Parts

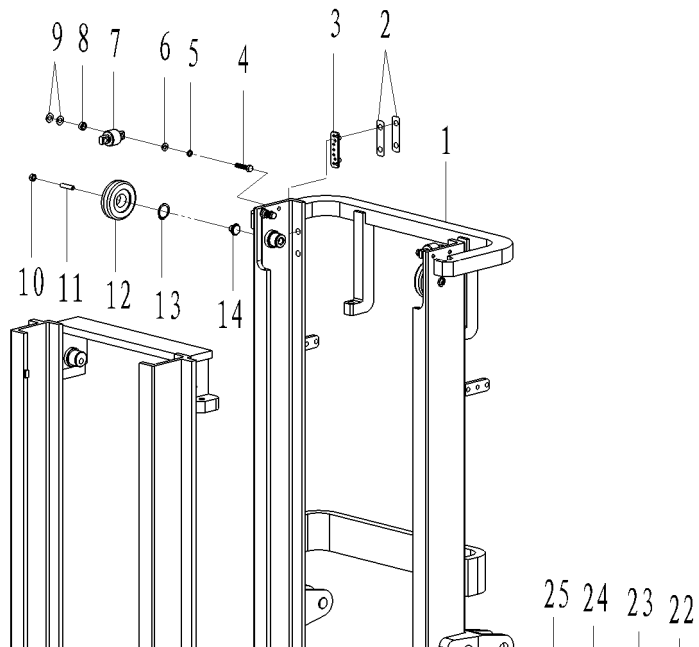

起升高度 Lifting Height	物料号	外门架总成 Outer mast	物料号	备注 Remark
	ID.		ID.	
3000	69102117	A15780-02000A-3.0M-Black	69102028	
3300	69102118	A15780-02000A-3.3M-Black	69102029	
3500	69102119	A15780-02000A-3.5M-Black	69102030	
3700	69102120	A15780-02000A-3.7M-Black	69102031	
4000	69102121	A15780-02000A-4.0M-Black	69102032	
4500	69102123	A15780-02000A-4.5M-Black	69102035	
5000	69102125	A15780-02000A-5.0M-Black	69109001	
5500	69102126	A15780-02000A-5.5M-Black	69102038	
6000	69102127	A15780-02000A-6.0M-Black	69102039	





图44/FIG. 44

门架(二级全自由)/MAST(FULL FREE 2-STAGE MAST)

FBA15/18-JZ

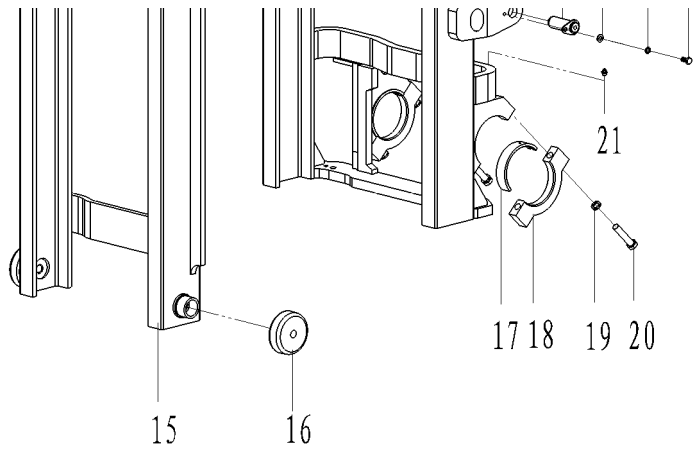
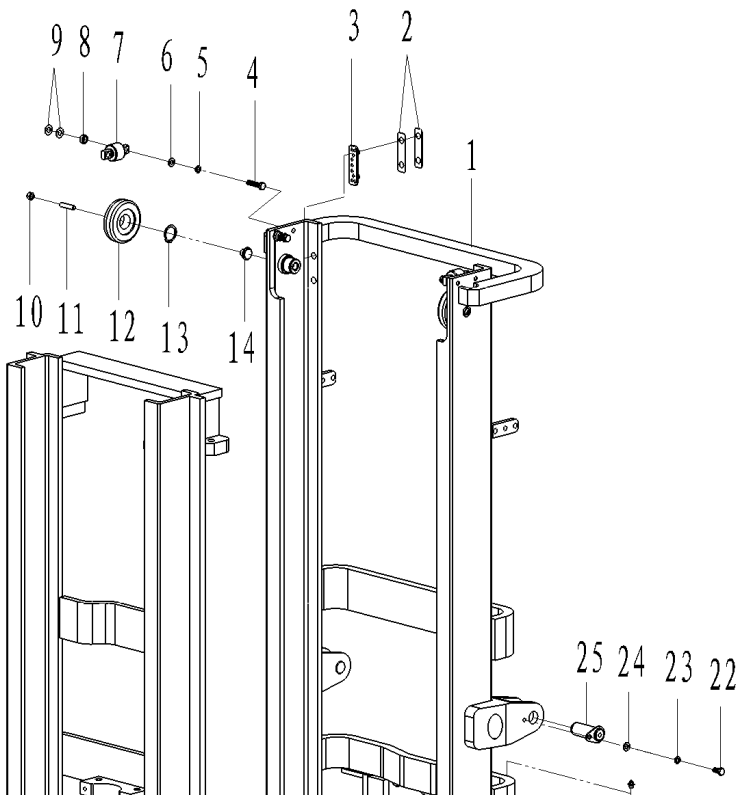

序号	物料号	代号	名称	数量	备注
Item No.	ID.	Part No.	Description	Q'ty	Remark
1	N/A	A15782-02000	Outer mast ass'y	1	140槽钢
-	N/A	A15782-02000A	Outer mast ass'y	1	14C槽钢
2	69009498	M3038000004/0.5	Adjusting shim set	AR	
3	69020280	M1538000003	Slipper	2	140槽钢用
-	69085545	M1538000003A	Slipper	2	14C槽钢用
4	69024917	GB/T5786-M10*1.25*45-8.8J	Bolt M10×1.25×45	4	
5	69000053	GB/T93-10	Washer 10	4	
6	69000250	GB/T97.1-10	Washer 10	4	
7	69005548	M1538012000	Sider roller CN-2	2	
8	69068137	M3038000012/18	Washer	4	
9	69012066	M3038000006/0.5	Adjusting shim set II	4组	
10	69011485	GB/T6171-M10*1-8J	Nut M10×1	2	
11	69021681	GB/T79-M10*1*45	Bolt M10×1×45	2	
12	69005550	M1538011000	Roller 180707K	2	
13	69005095	GB/T894.1-Φ35	Snap spring35	2	
14	69012654	M3038000010	Adjusting shim	2	











图45/FIG. 45

门架(三级全自由)/MAST(FULL FREE 3-STAGE MAST)

FBA15/18-JZ

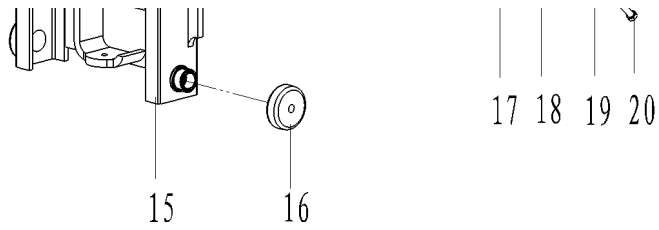
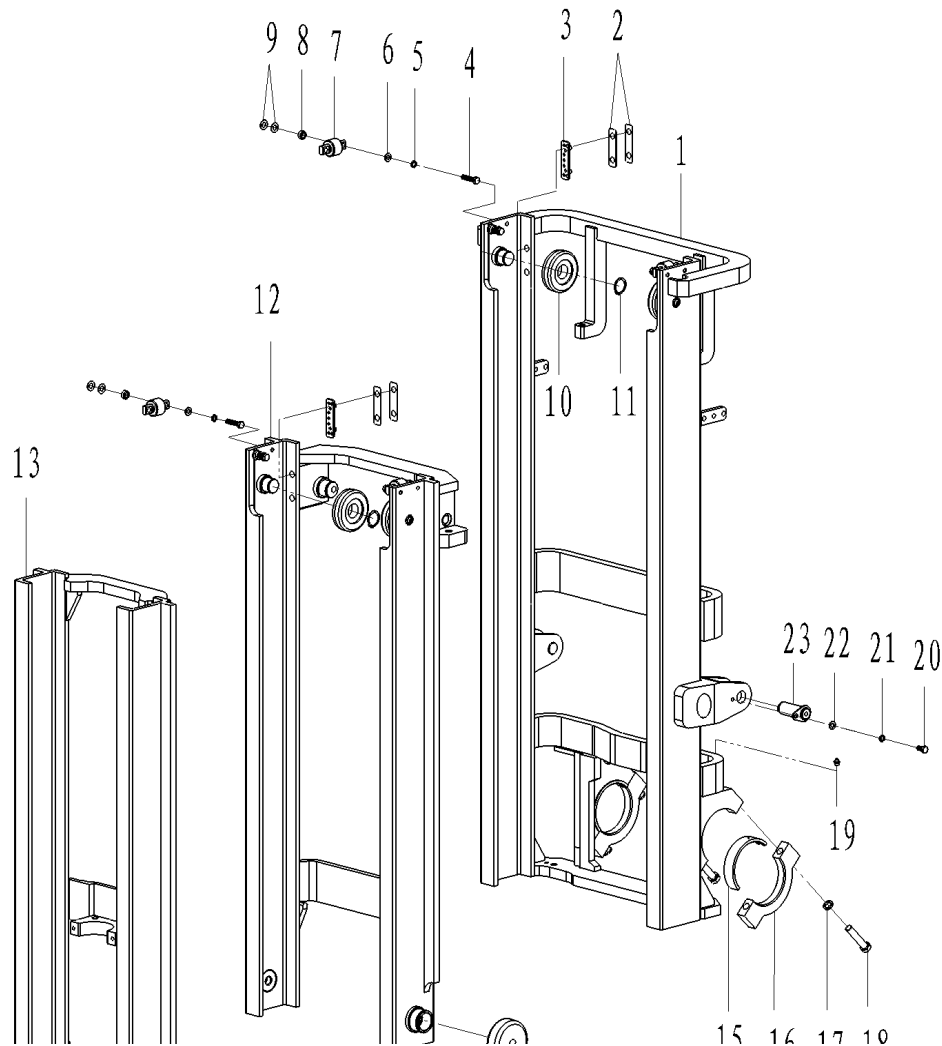

序号 Item No.	物料号 ID.	代号 Part No.	名称 Description	数量 Q' ty	备注 Remark
1	N/A	A15784-03000	Outer mast ass'y	1	140槽钢
-	N/A	A15784-03000A	Outer mast ass'y	1	14C槽钢
2	69009498	M3038000004/0.5	Adjusting shim set	AR	
3	69020280	M1538000003	Slipper	2	140槽钢用
-	69085545	M1538000003A	Slipper	2	14C槽钢用
4	69024917	GB/T5786-M10*1.25*45-8.8J	Bolt M10×1.25×45	8	
5	69000053	GB/T93-10	Washer 10	8	
6	69000250	GB/T97.1-10	Washer 10	8	
7	69005548	M1538012000	Side roller CN-2	4	
8	69068137	M3038000012/18	Washer	8	
9	69012066	M3038000006/0.5	Adjusting shim set II	8组	
10	69005550	M1538011000	Roller 180707K	4	
11	69005095	GB/T894.1-Φ35	Snap spring 35	4	
12	N/A	M15074004000	Middle mast ass'y	1	140槽钢
-	N/A	M15074004000A	Middle mast ass'y	1	14C槽钢
13	N/A	M15074003000	Inner mast ass'y	1	140槽钢
-	N/A	M15074003000A	Inner mast ass'y	1	14C槽钢
14	69007470	15S02-02005	Combination roller 760211AT	4	140槽钢用
-	69085543	15S02-02005A	Combination roller 760211N3T	4	14C槽钢用
15	69009371	M1538000002	Bearing liner	2	
16	69009487	M1538000001	Bearing cap	2	





图45/FIG. 45

门架(三级全自由)/MAST(FULL FREE 3-STAGE MAST)

FBA15/18-JZ

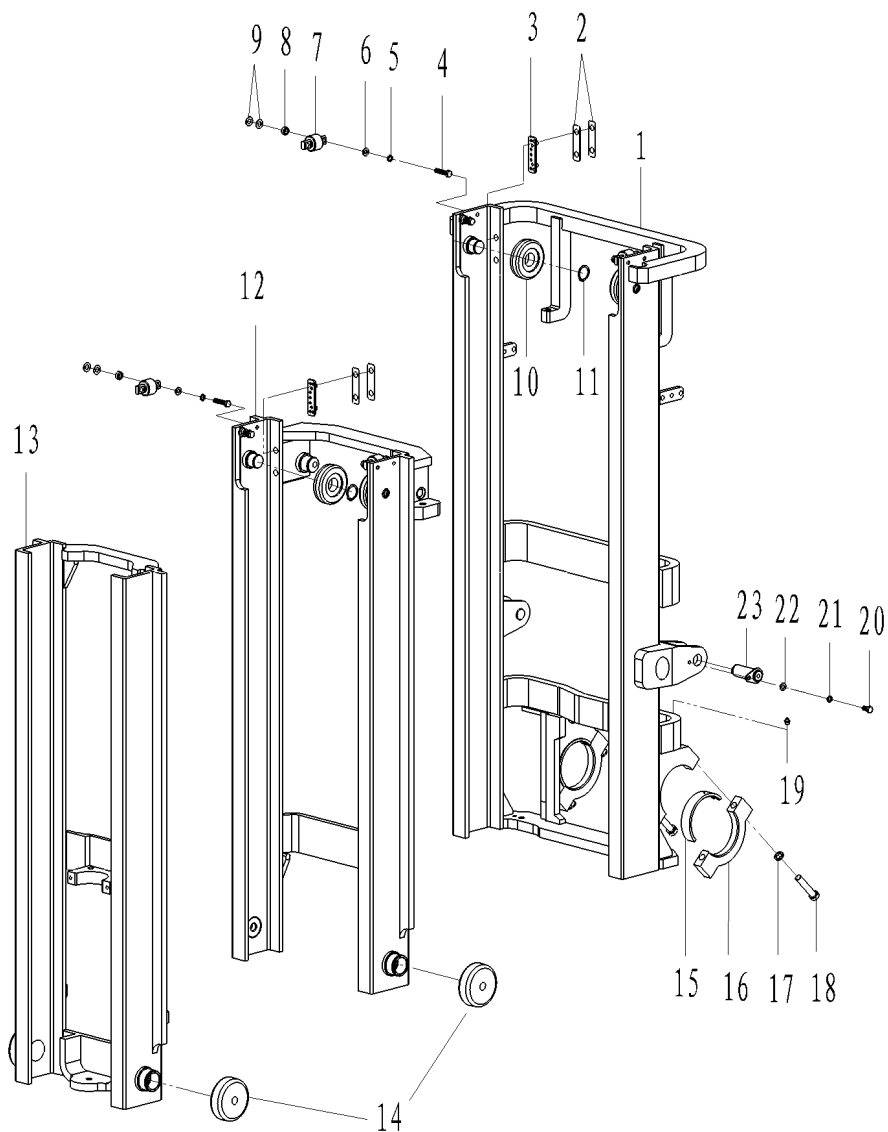

门架选用表(140槽钢) Mast Optional Parts

起升高度 Lifting Height	物料号	内门架总成 Inter mast			
	ID.				
3600	69109473	M15074003000A-3.6M-Black			
4000	69109474	M15074003000A-4.0M-Black			
4350	69109475	M15074003000A-4.35M-Black			
4500	69104353	M15074003000A-4.5M-Black			
4800	69104356	M15074003000A-4.8M-Black			
5000	69104355	M15074003000A-5.0M-Black			
5500	69104357	M15074003000A-5.5M-Black			
6000	69104360	M15074003000A-6.0M-Black			

图46/FIG. 46

门架(基本型)/MAST(NORMAL MAST)

FBA20/25-JZ

序号	物料号	代号	名称	数量	备注
Item No.	ID.	Part No.	Description	Q'ty	Remark

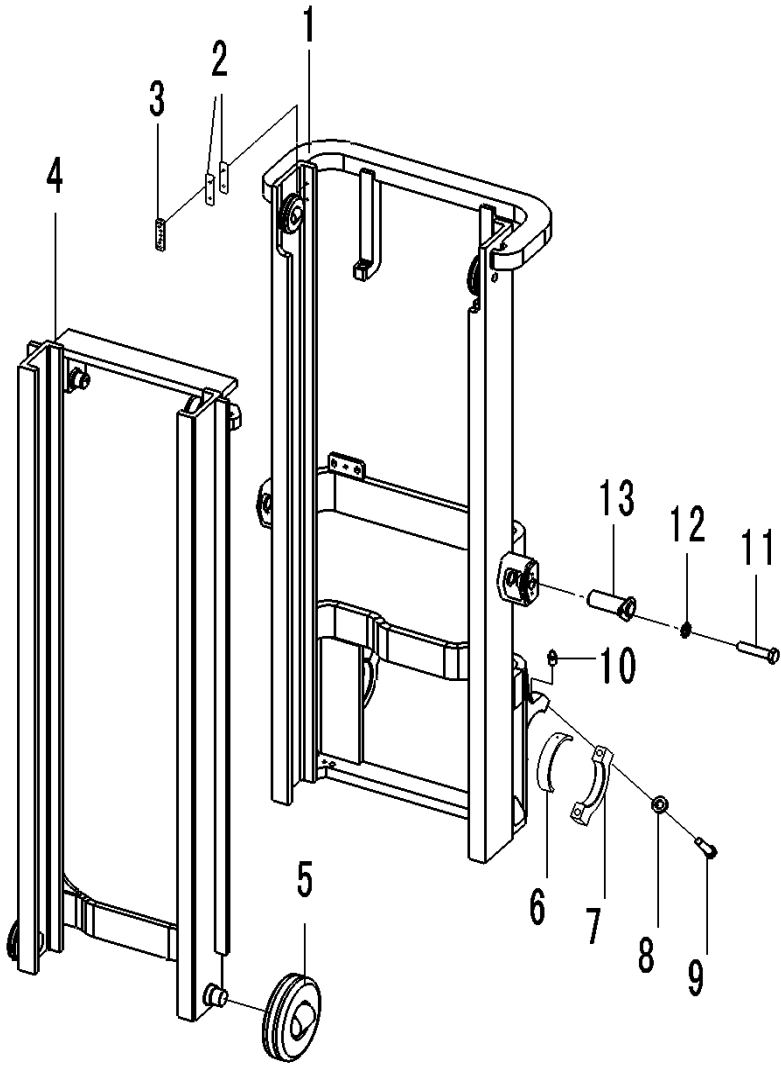

01	N/A	A25780-05000	Outer mast ass'y	1	
02	69009498	M3038000004/0.5	Adjusting washer	2组	
03	69034185	A30480-00001	Slipper	2	
04	N/A	A25780-04000	Inner mast ass'y	1	
05	69020211	A25780-06000	Combination roller 760211K1T	4	
06	69012068	M3038000002	Bearing liner	2	
07	69004874	M3038000001	Bearing cap	2	
08	69000056	GB/T93-16	Washer 16	4	
09	69042802	GB/T5785-M16*1.5*70-8.8J	Bolt M16×1.5×70	4	
10	69003941	JB/T7940.1-M10*1	Nipple M10×1	2	
11	69000123	GB/T5783-M10*20-8.8J	Bolt M10×20	2	
12	69000053	GB/T93-10	Washer 10	2	
13	69070207	A25780-07000	Pin shaft	2	

图46/FIG. 46 门架(基本型)/MAST(NORMAL MAST)

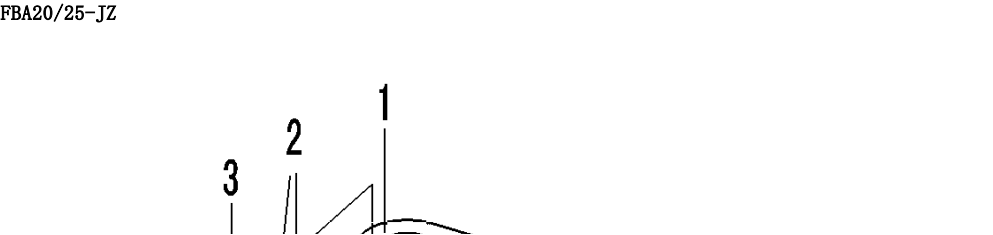

门架选用表 Mast Optional Parts				
起升高度 Lifting Height	物料号	外门架总成 Outer mast	物料号	备注 Remark
	ID.		ID.	
3000	69109008	A25780-05000-3.0M-Black	69116540	
3300	69109009	A25780-05000-3.3M-Black	69116541	

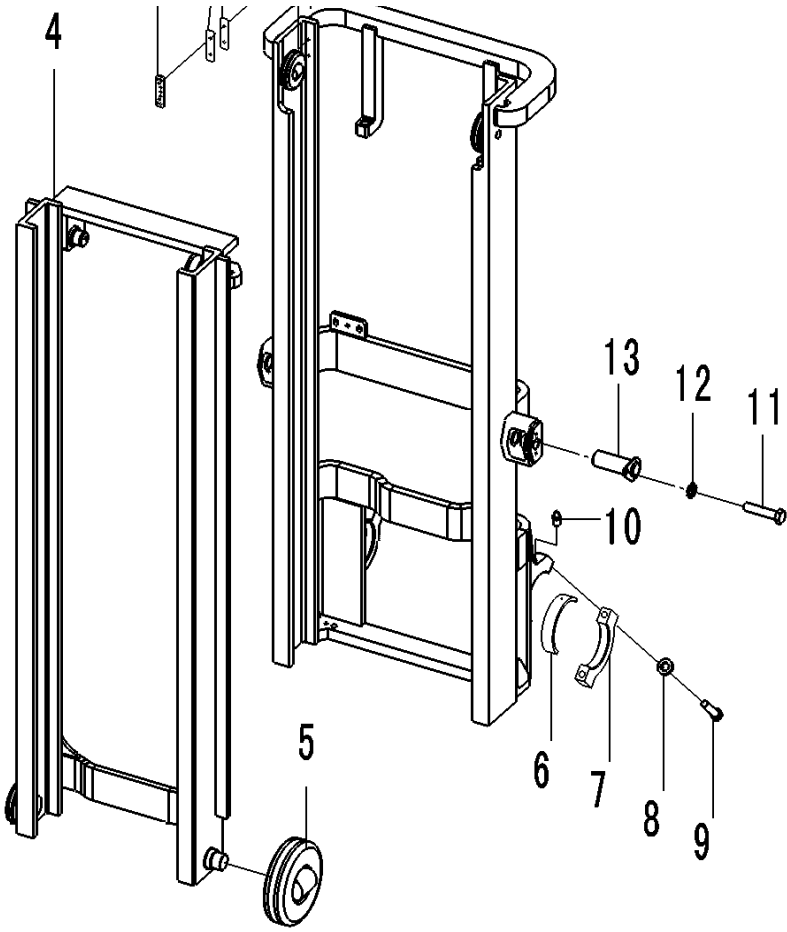

3500	69102155	A25780-05000-3.5M-Black	69116542	
3700	69102156	A25780-05000-3.7M-Black	69116543	
4000	69102157	A25780-05000-4.0M-Black	69116544	
4500	69102158	A25780-05000-4.5M-Black	69116545	
5000	69102159	A25780-05000-5.0M-Black	69116546	
5500	69102160	A25780-05000-5.5M-Black	69116547	
6000	69102161	A25780-05000-6.0M-Black	69116548	

图47/FIG. 47 门架(二级全自由)/MAST(FULL FREE 2-STAGE MAST)

FBA20/25-JZ

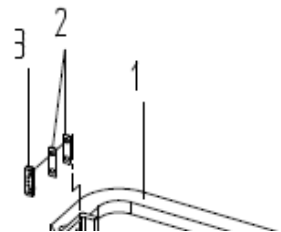

序号	物料号	代号	名称	数量	备注
Item No.	ID.	Part No.	Description	Q'ty	Remark
01	N/A	A25782-04000	Outer mast ass'y	1	
02	69009498	M3038000004/0.5	Adjusting washer	2组	
03	69034185	A30480-00001	Slipper	2	
04	N/A	A25782-03000A	Inner mast ass'y	1	
05	69020211	A25780-06000	Combination roller 760211KIT	4	
06	69012068	M3038000002	Bearing liner	2	

4  
1

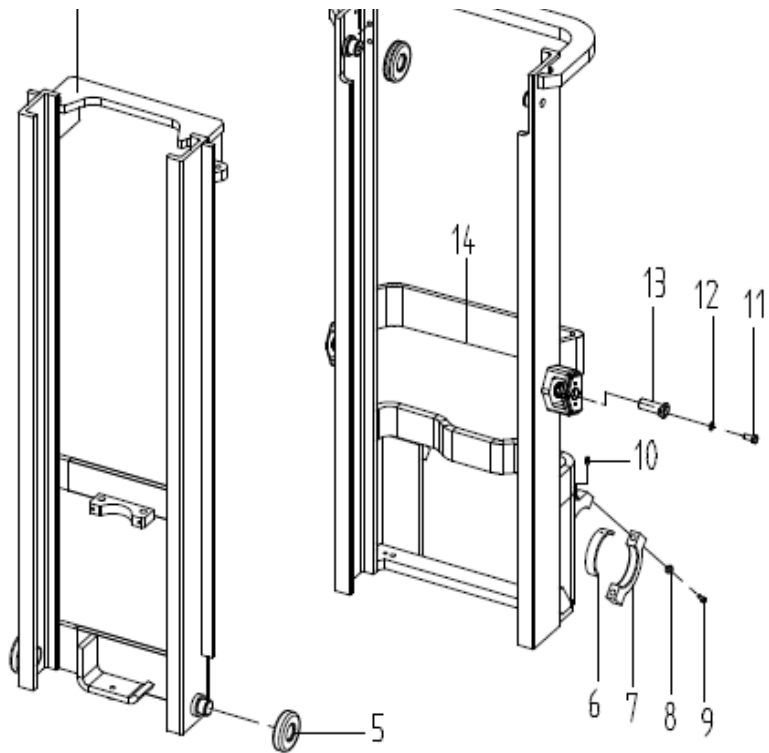

07	69004874	M3038000001	Bearing cap	2	
08	69000056	GB/T93-16	Washer 16	4	
09	69042802	GB/T5785-M16*1.5*70-8.8J	Bolt M16×1.5×70	4	
10	69003941	JB/T7940.1-M10*1	Nipple M10×1	2	
11	69000123	GB/T5783-M10*20-8.8J	Bolt M10×20	2	
12	69000053	GB/T93-10	Washer 10	2	
13	69070207	A25780-07000	Pin shaft	2	

图47/FIG. 47 门架(二级全自由)/MAST(FULL FREE 2-STAGE MAST)

FBA20/25-JZ

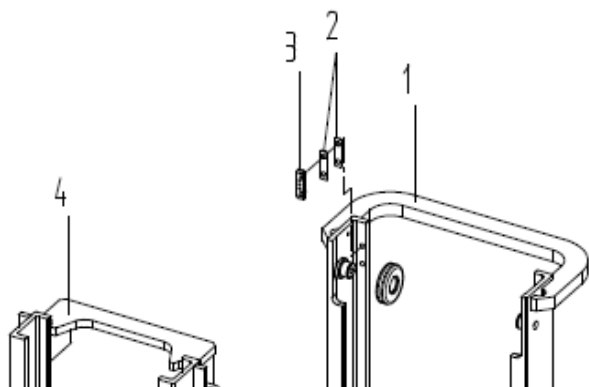

门架选用表 Mast Optional Parts

起升高度 Lifting Height	物料号	外门架总成 Outer mast	内门架总成 Inner mast	备注 Remark
	ID.			
3000	69102164	A25782-04000-3.0M-Black	69101937	
3300	69102165	A25782-04000-3.3M-Black	69101939	
3500	69102166	A25782-04000-3.5M-Black	69101941	
3700	69102167	A25782-04000-3.7M-Black	69101942	
4000	69102168	A25782-04000-4.0M-Black	69101944	
4500	69102169	A25782-04000-4.5M-Black	69101946	
5000	69102170	A25782-04000-5.0M-Black	69101948	
5500	69102171	A25782-04000-5.5M-Black	69101950	

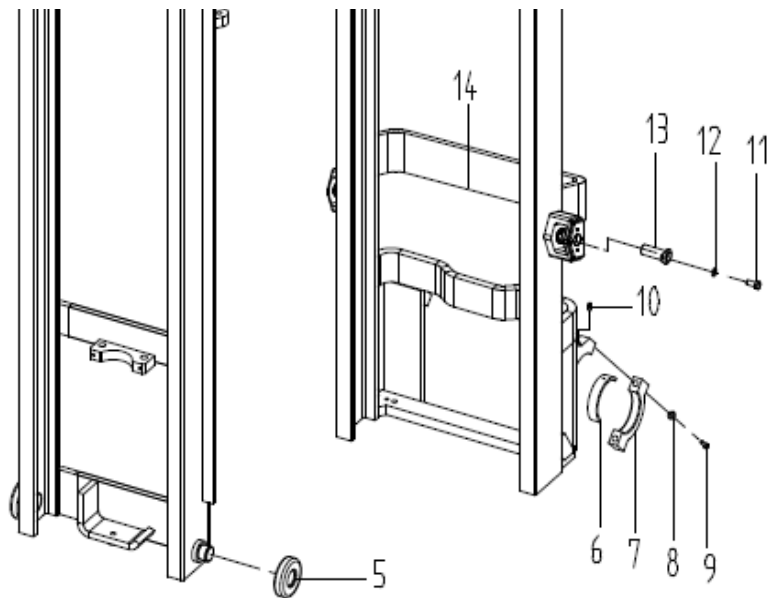

6000	69102172	A25782-04000-6.0M-Black	69101951	

图48/FIG. 48 门架(三级全自由)/MAST(FULL FREE 3-STAGE MAST)

FBA20/25-JZ

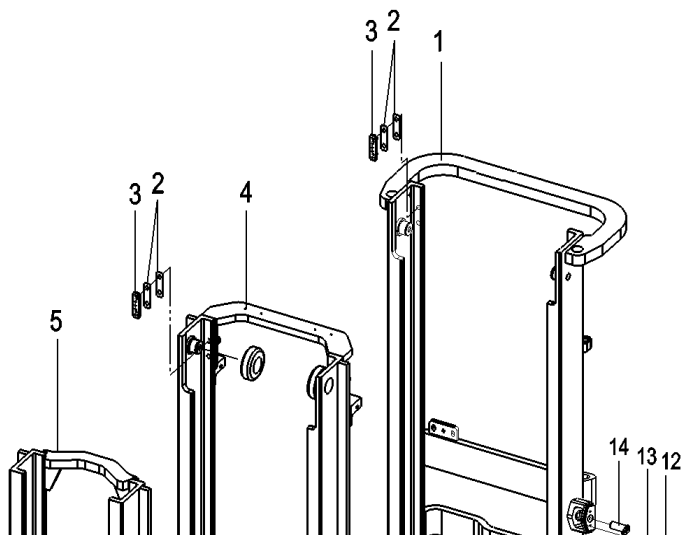

序号 Item No.	物料号 ID.	代号 Part No.	名称 Description	数量 Q'ty	备注 Remark
01	N/A	A25784-05000	Outer mast ass'y	1	
02	69009498	M3038000004/0.5	Adjusting washer	2组	
03	69034185	A30480-00001	Slipper	2	
04	N/A	A25784-04000	Middle mast ass'y	1	
05	N/A	A25784-03000	Inner mast ass'y	1	
06	69020211	A25780-06000	Combination roller 760211KIT	8	
07	69012068	M3038000002	Bearing liner	2	
08	69004874	M3038000001	Bearing cap	2	
09	69000056	GB/T93-16	Washer 16	4	
10	69042802	GB/T5785-M16*1.5*70-8.8J	Bolt M16×1.5×70	4	
11	69003941	JB/T7940.1-M10*1	Nipple M10×1	2	
12	69000123	GB/T5783-M10*20-8.8J	Bolt M10×20	2	



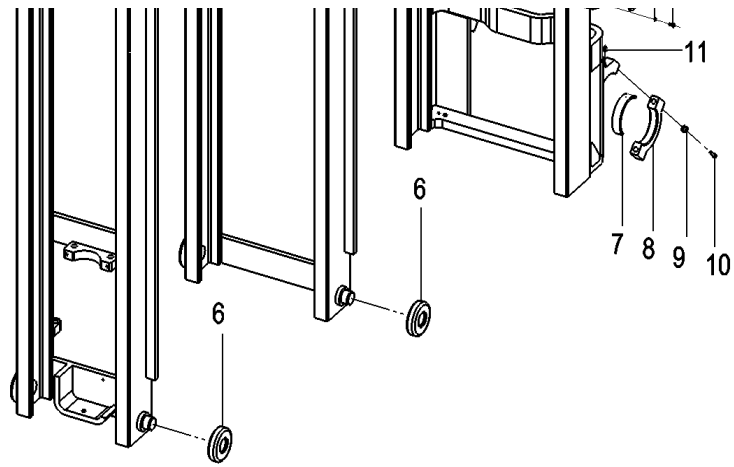

13	69000053	GB/T93-10	Washer 10	2	
14	69070207	A25780-07000	Pin shaft	2	

图48/FIG. 48

门架(三级全自由)/MAST(FULL FREE 3-STAGE MAST)

FBA20/25-JZ

门架选用表 Mast Optional Parts

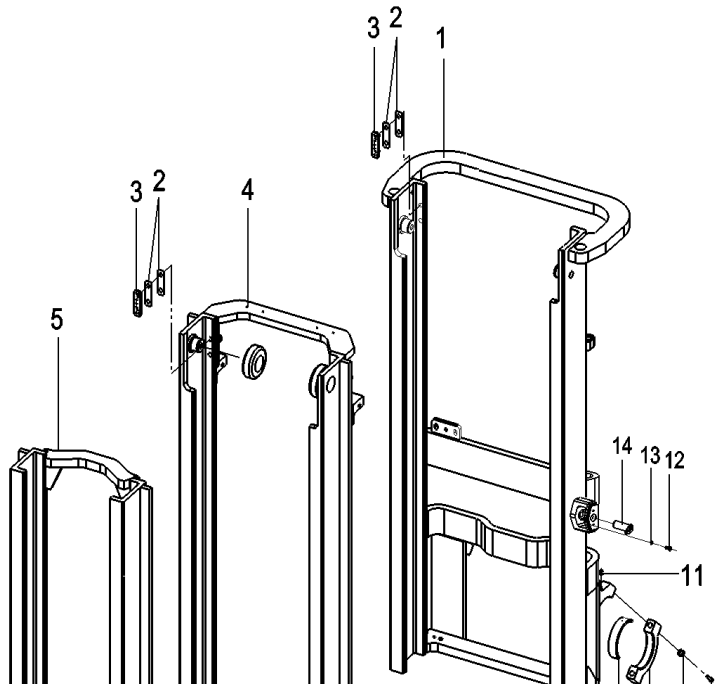

起升高度 Lifting Height	物料号	外门架总成 Outer mast	物料号	备注 Remark
	ID.		ID.	
3600	69102173	A25784-05000-3.6M-Black	69102248	
4000	69102174	A25784-05000-4.0M-Black	69102249	
4350	69102175	A25784-05000-4.35M-Black	69102251	
4500	69102176	A25784-05000-4.5M-Black	69102252	
4800	69102177	A25784-05000-4.8M-Black	69102253	
5000	69102178	A25784-05000-5.0M-Black	69102254	
5500	69102179	A25784-05000-5.5M-Black	69102255	
6000	69102180	A25784-05000-6.0M-Black	69102256	
6500	69102181	A25784-05000-6.5M-Black	69102257	





图49/FIG. 49

门架(基本型)/MAST(NORMAL MAST)

FBA30/35-JZ



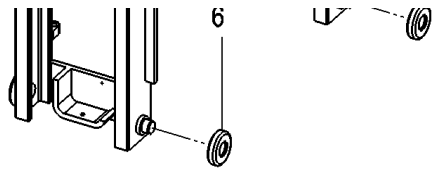
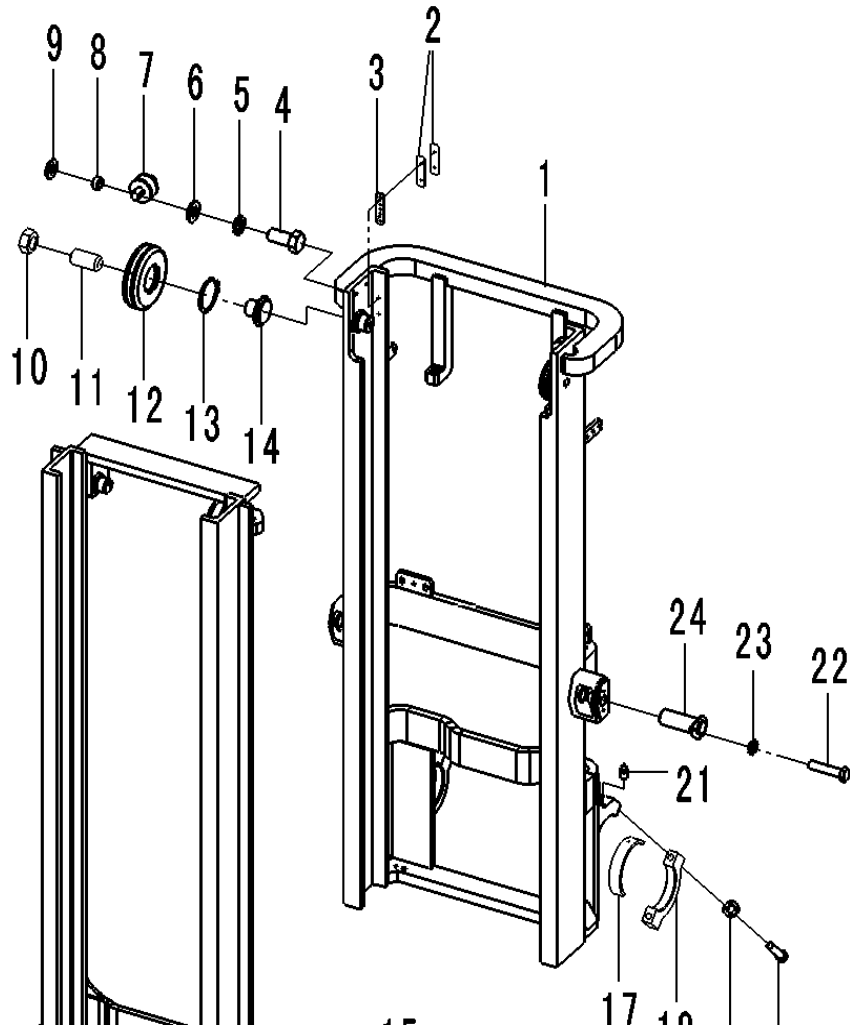

序号	物料号	代号	名称	数量	备注
Item No.	ID.	Part No.	Description	Q' ty	Remark
01	N/A	A30780-05000	Outer mast ass'y	1	FBA30-JZ
-	N/A	A35780-03000	Outer mast ass'y	1	FBA35-JZ
02	69009498	M3038000004/0.5	Adjusting washer	2组	
03	69034185	A30480-00001	Slipper	2	
04	69024917	GB/T5786-M10*1.25*45-8.8J	Bolt M10×1.25×45	4	
05	69000053	GB/T93-10	Washer 10	4	
06	69000250	GB/T97.1-10	Washer 10	4	
07	69021881	M3038010000	Side roller C2-3	2	
08	69068137	M3038000012/18	Washer	4	
09	69012066	M3038000006/0.5	Adjusting washer II	2组	
10	69011485	GB/T6171-M10*1-8J	Nut M10×1	2	
11	69006729	GB/T77-M10*45-12.9J	Bolt M10×45	2	
12	69002362	M3038008000	Roller 130309KT	2	
13	69000071	GB/T894.1-Φ45	Snap ring 45	2	
14	69012654	M3038000010	Adjusting shim	2	
15	N/A	A30780-04000	Inner mast ass'y	1	FBA30-JZ
-	N/A	A35780-02000	Inner mast ass'y	1	FBA35-JZ
16	69021690	M3038007000	Combination roller 760311NT	2	
17	69012068	M3038000002	Bearing liner	2	
18	69004874	M3038000001	Bearing cap	2	
19	69000056	GB/T93-16	Washer 16	4	



图49/FIG. 49

门架(基本型)/MAST(NORMAL MAST)

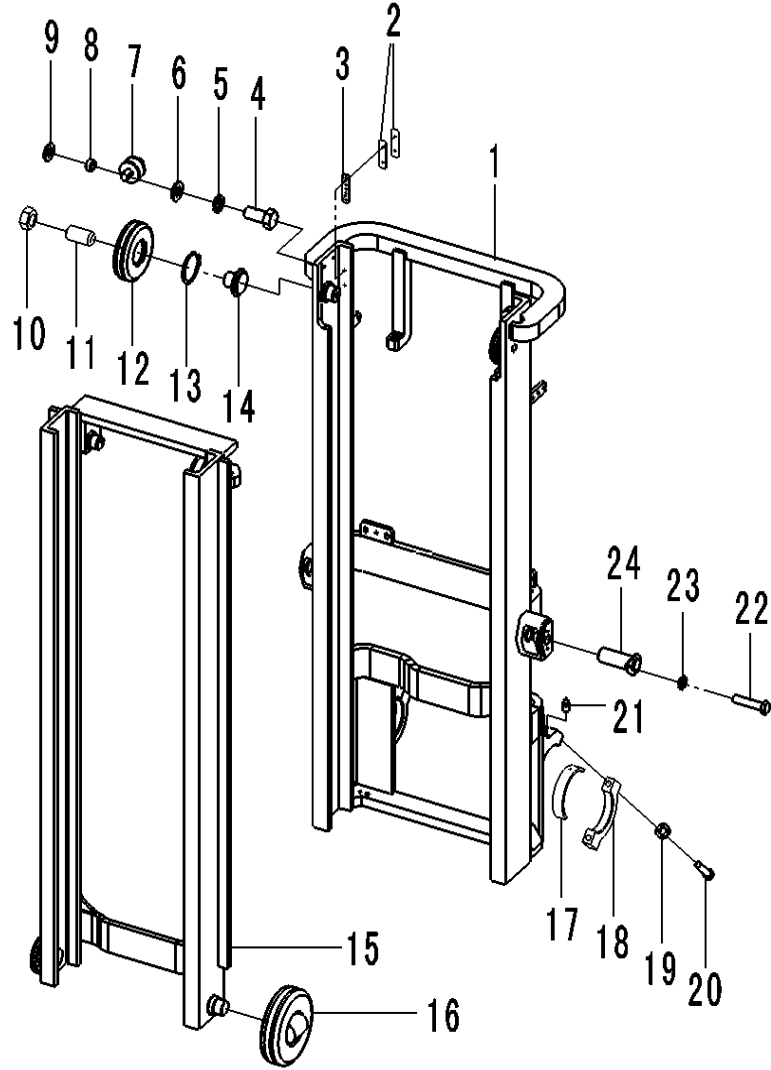
FBA30/35-JZ



门架选用表 Mast Optional Parts

起升高度 Lifting Height	物料号	外门架总成 Outer mast	物料号	备注 Remark
	ID.		ID.	
3000	69109013	A35780-03000-3.0M-Black	69108988	
3300	69102218	A35780-03000-3.3M-Black	69108989	
3500	69102219	A35780-03000-3.5M-Black	69108990	
3700	69102221	A35780-03000-3.7M-Black	69108992	
4000	69102222	A35780-03000-4.0M-Black	69108993	
4500	69102224	A35780-03000-4.5M-Black	69108995	
5000	69102226	A35780-03000-5.0M-Black	69108997	
5500	69102227	A35780-03000-5.5M-Black	69108998	
6000	69102228	A35780-03000-6.0M-Black	69108999	

图50/FIG. 50

门架(二级全自由)/MAST(FULL FREE 2-STAGE MAST)

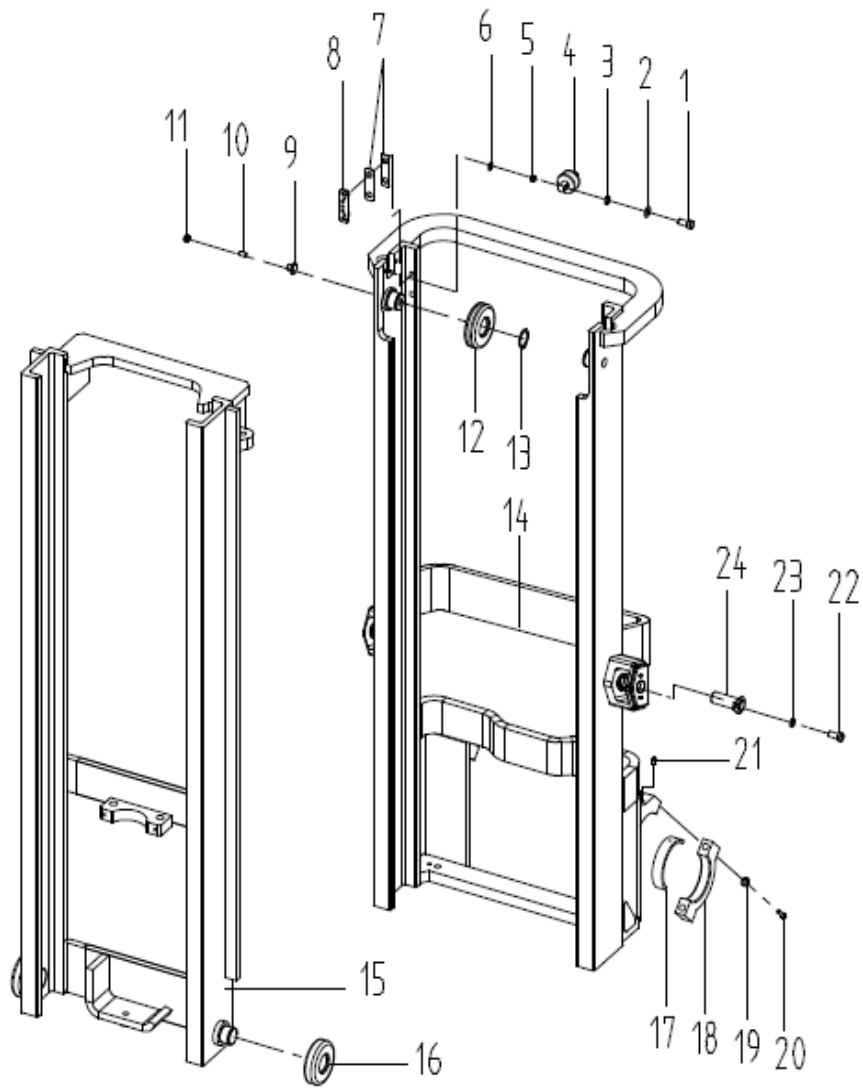

序号	物料号	代号	名称	数量	备注
Item No.	ID.	Part No.	Description	Q'ty	Remark
01	69024917	GB/T5786-M10*1.25*45-8.8J	Bolt M10×1.25×45	4	
02	69000053	GB/T93-10	Washer 10	4	
03	69000250	GB/T97.1-10	Washer 10	4	
04	69021881	M3038010000	Side roller C2-3	2	
05	69068137	M3038000012/18	Washer	4	
06	69012066	M3038000006/0.5	Adjusting washer II	2组	
07	69009498	M3038000004/0.5	Adjusting washer	2组	
08	69034185	A30480-00001	Slipper	2	
09	69012654	M3038000010	Adjusting shim	2	
10	69011485	GB/T6171-M10*1-8J	Nut M10×1	2	
11	69006729	GB/T77-M10*45-12.9J	Bolt M10×45	2	
12	69002362	M3038008000	Roller 130309KT	2	
13	69000071	GB/T894.1-Φ45	Snap ring 45	2	
14	N/A	A30782-04000	Outer mast ass'y	1	FBA30-JZ
-	N/A	A35782-02000	Outer mast ass'y	1	FBA35-JZ
15	N/A	A30782-03000	Inner mast ass'y	1	FBA30-JZ
-	N/A	A35782-03000	Inner mast ass'y	1	FBA35-JZ
16	69021690	M3038007000	Combination roller 760311NT	2	
17	69012068	M3038000002	Bearing liner	2	
18	69004874	M3038000001	Bearing cap	2	
19	69000056	GB/T93-16	Washer 16	4	
20	69042802	GB/T5785-M16*1.5*70-8.8J	Bolt M16×1.5×70	4	
21	69003941	JB/T7940.1-M10*1	Nipple M10×1	2	
22	69000123	GB/T5783-M10*20-8.8J	Bolt M10×20	2	
23	69000053	GB/T93-10	Washer 10	2	
24	69070207	A25780-07000	Pin shaft	2	

图50/FIG. 50

门架(二级全自由)/MAST(FULL FREE 2-STAGE MAST)



图50/FIG. 50

门架(二级全自由)/MAST(FULL FREE 2-STAGE MAST)

7 6 5 4 3 2 1

门架选用表 Mast Optional Parts

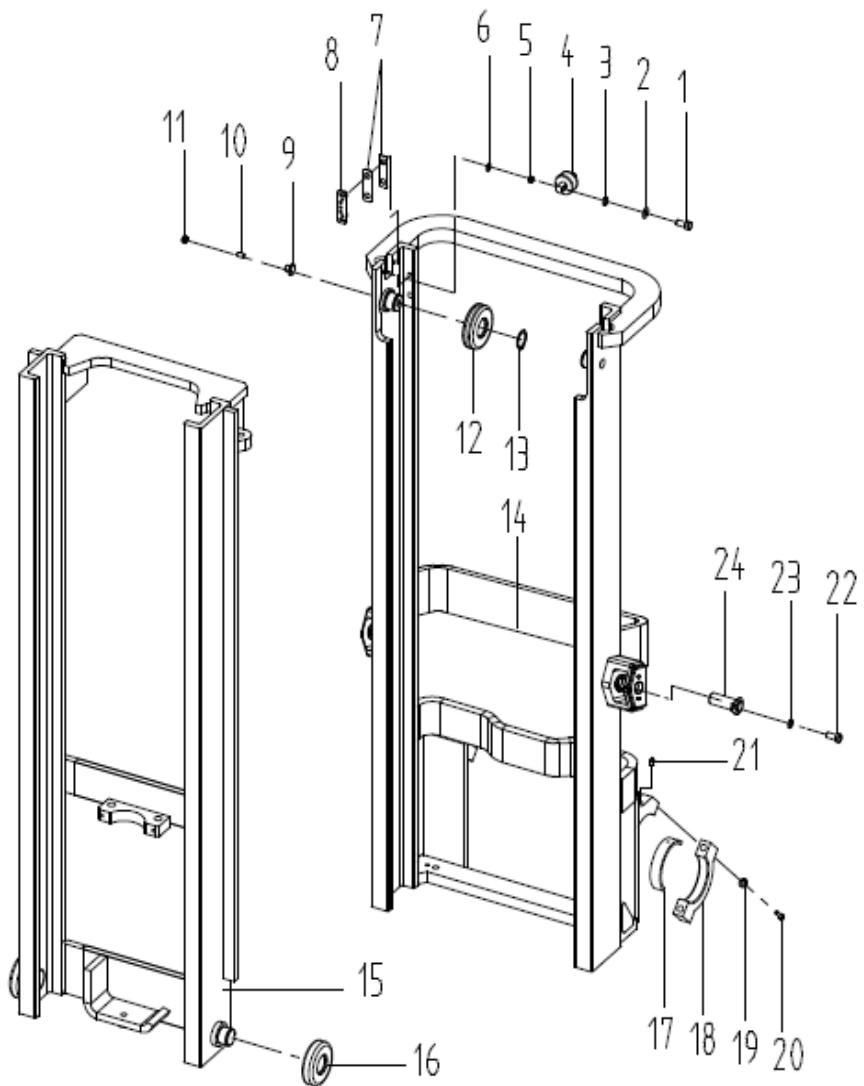
起升高度 Lifting Height	物料号	外门架总成 Outer mast	物料号	备注 Remark
	ID.		ID.	
3000	69102194	A30782-04000-3.0M-Black	69108982	
3300	69102195	A30782-04000-3.3M-Black	69108983	
3500	69102196	A30782-04000-3.5M-Black	69101966	
3700	69102197	A30782-04000-3.7M-Black	69101967	
4000	69102198	A30782-04000-4.0M-Black	69101968	
4500	69102199	A30782-04000-4.5M-Black	69101969	
5000	69102200	A30782-04000-5.0M-Black	69108984	
5500	69102201	A30782-04000-5.5M-Black	69101972	
6000	69102202	A30782-04000-6.0M-Black	69101973	

门架选用表 Mast Optional Parts

起升高度 Lifting Height	物料号	外门架总成 Outer mast	物料号	备注 Remark
	ID.		ID.	

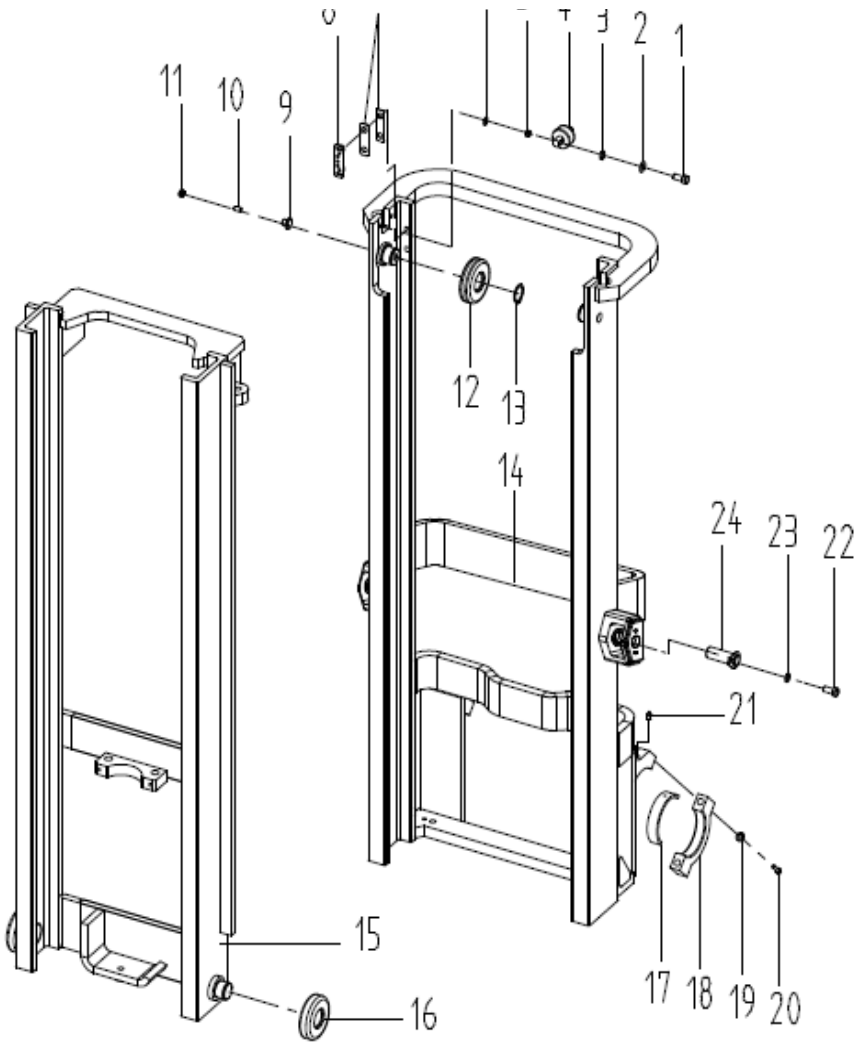

3000	69109014	A35782-02000-3.0M-Black	69101989	
3300	69102230	A35782-02000-3.3M-Black	69101990	
3500	69102231	A35782-02000-3.5M-Black	69101991	
3700	69102232	A35782-02000-3.7M-Black	69101992	
4000	69102233	A35782-02000-4.0M-Black	69101993	
4500	69102234	A35782-02000-4.5M-Black	69101994	
5000	69102235	A35782-02000-5.0M-Black	69101995	
5500	69102236	A35782-02000-5.5M-Black	69101996	
6000	69102237	A35782-02000-6.0M-Black	69101998	

图51/FIG. 51 门架(三级全自由)/MAST(FULL FREE 3-STAGE MAST)

FBA30/35-JZ

序号 Item No.	物料号 ID.	代号 Part No.	名称 Description	数量 Q'ty	备注 Remark
01	69024917	GB/T5786-M10*1.25*45-8.8J	Bolt M10×1.25×45	4	
02	69000053	GB/T93-10	Washer 10	4	
03	69000250	GB/T97.1-10	Washer 10	4	
04	69021881	M3038010000	Side roller C2-3	2	

8 7  
1 1      6 5 4 3 2 1



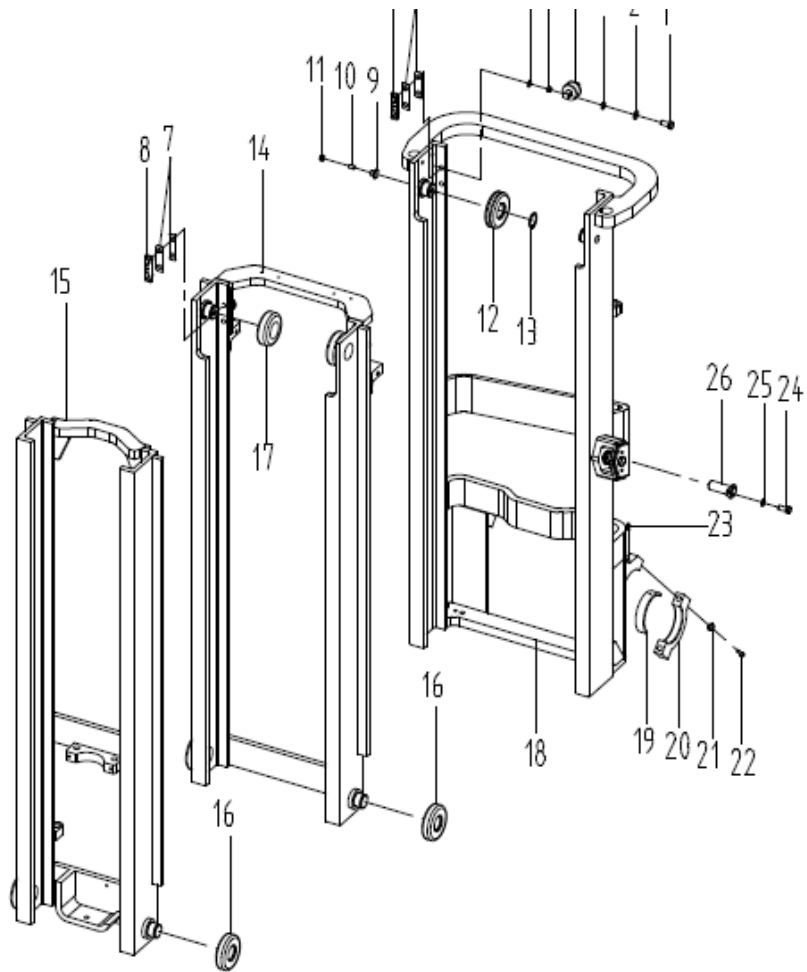

05	69068137	M3038000012/18	Adjusting washer	2组	
06	69012066	M3038000006/0.5	Adjusting washer II	2组	
07	69009498	M3038000004/0.5	Adjusting washer	4组	
08	69034185	A30480-00001	Slipper	2	
09	69012654	M3038000010	Adjusting shim	2	
10	69006729	GB/T77-M10*45-12.9J	Bolt M10×45	2	
11	69011485	GB/T6171-M10*1-8J	Nut M10×1	2	
12	69002362	M3038008000	Roller 130309KT	2	
13	69000071	GB/T894.1-Φ45	Snap ring 45	2	
14	N/A	A30784-04000	Middle mast ass'y	1	FBA30-JZ
-	N/A	A35784-04000	Middle mast ass'y	1	FBA35-JZ
15	N/A	A30784-03000	Inner mast ass'y	1	FBA30-JZ
-	N/A	A35784-03000	Inner mast ass'y	1	FBA35-JZ
16	69021690	M3038007000	Combination roller 760311NT	4	
17	69021689	M30074006000	Combination roller 760211NT	2	
18	N/A	A30784-05000	Outer mast ass'y	1	FBA30-JZ
-	N/A	A35784-05000	Outer mast ass'y	1	FBA35-JZ
19	69012068	M3038000002	Bearing liner	2	
20	69004874	M3038000001	Bearing cap	2	
21	69000056	GB/T93-16	Washer 16	4	
22	69042802	GB/T5785-M16*1.5*70-8.8J	Bolt M16×1.5×70	4	
23	69003941	JB/T7940.1-M10*1	Nipple M10×1	2	

图51/FIG. 51

门架(三级全自由)/MAST(FULL FREE 3-STAGE MAST)

FBA30/35-JZ

序号	物料号	代号	名称	数量	备注
Item No.	ID.	Part No.	Description	Q'ty	Remark
24	69000123	GB/T5783-M10*20-8.8J	Bolt M10×20	2	
25	69000053	GB/T93-10	Washer 10	2	
26	69070207	A25780-07000	Pin shaft	2	





图51/FIG. 51 门架(三级全自由)/MAST (FULL FREE 3-STAGE MAST)

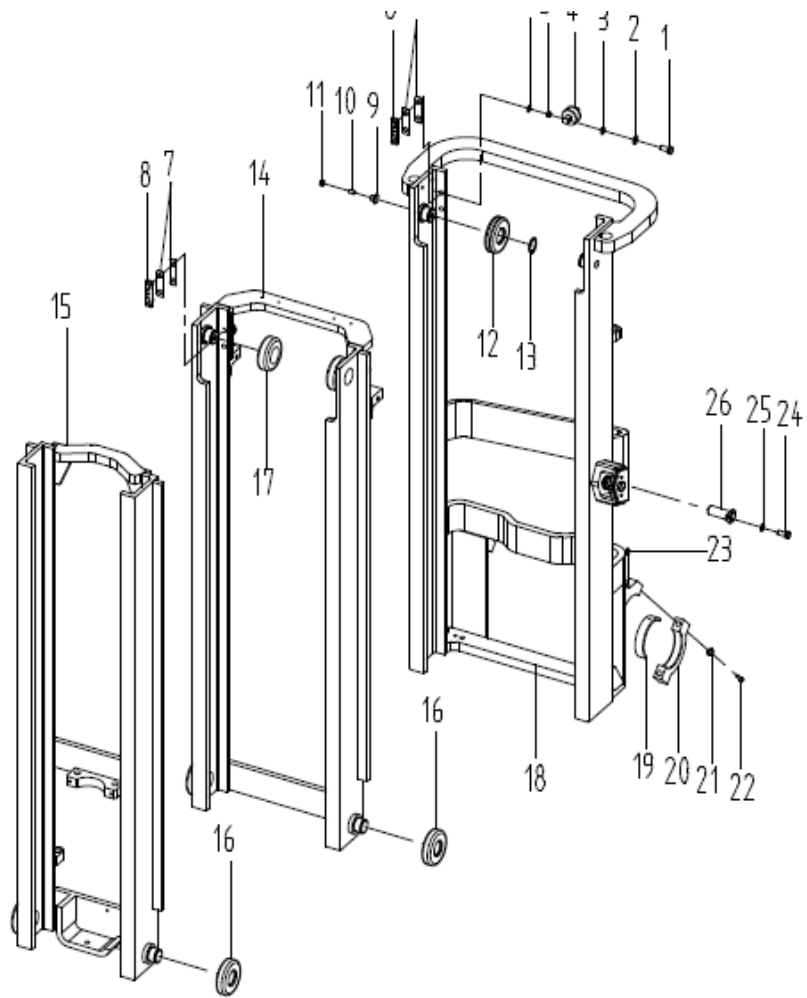
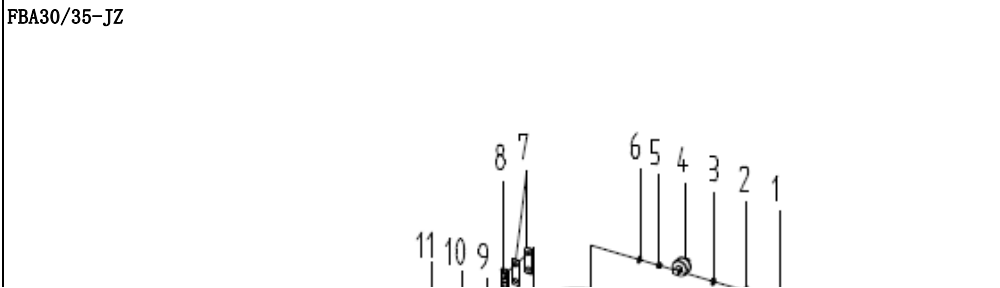
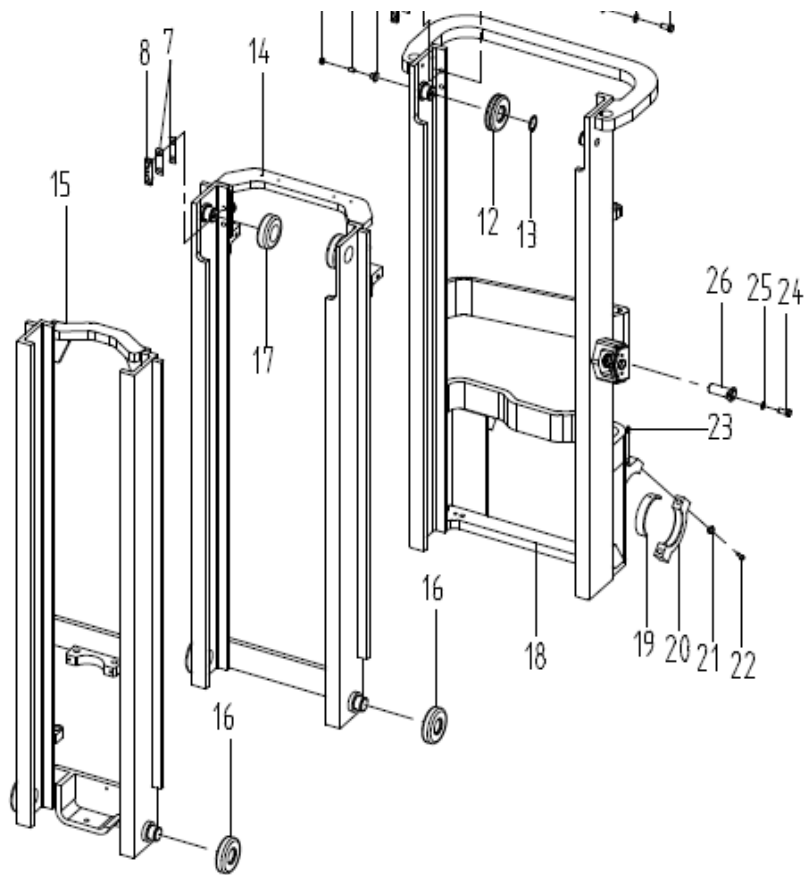

门架选用表 Mast Optional Parts

起升高度 Lifting Height	物料号	外门架总成 Outer mast	物料号	备注 Remark
	ID.		ID.	
3600	69102203	A30784-05000-3.6M-Black	69102258	
4000	69102204	A30784-05000-4.0M-Black	69102259	
4350	69102205	A30784-05000-4.35M-Black	69102260	



4500	69102206	A30784-05000-4.5M-Black	69102261	
4800	69102207	A30784-05000-4.8M-Black	69102262	
5000	69102208	A30784-05000-5.0M-Black	69102263	
5400	69102209	A30784-05000-5.4M-Black	69102264	
5500	69102210	A30784-05000-5.5M-Black	69102265	
6000	69102211	A30784-05000-6.0M-Black	69102266	
6500	69102212	A30784-05000-6.5M-Black	69102267	

图51/FIG. 51 门架(三级全自由)/MAST(FULL FREE 3-STAGE MAST)

FBA30/35-JZ

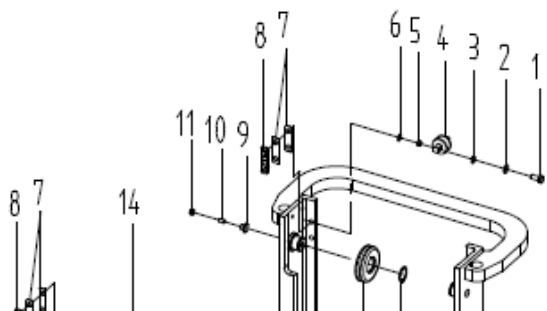

门架选用表 Mast Optional Parts

起升高度 Lifting Height	物料号	内门架总成 Inner mast		备注 Remark
	ID.			
3600	69102049	A30784-03000-3.6M-Black		
4000	69102050	A30784-03000-4.0M-Black		
4350	69102051	A30784-03000-4.35M-Black		
4500	69102052	A30784-03000-4.5M-Black		
4800	69102053	A30784-03000-4.8M-Black		
5000	69102054	A30784-03000-5.0M-Black		

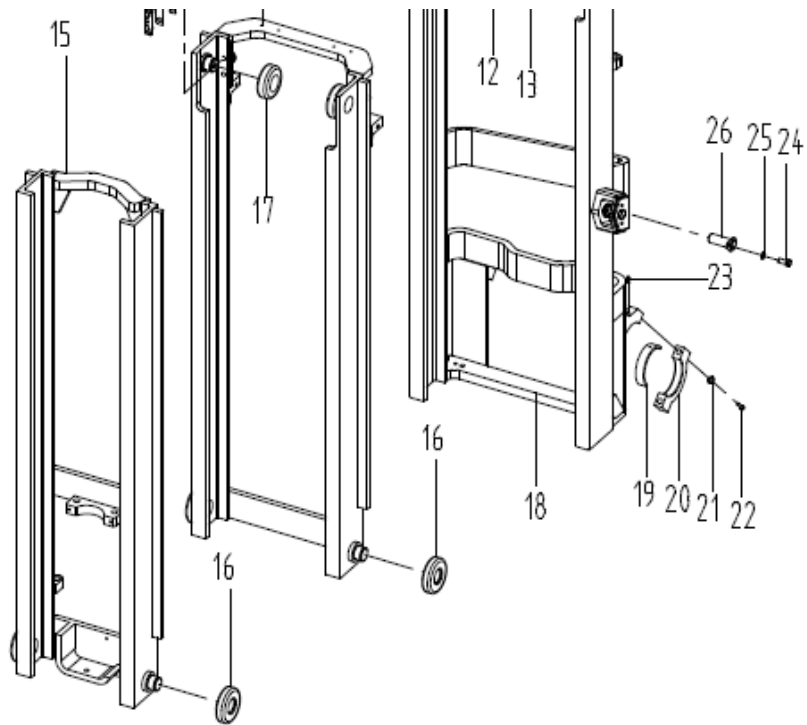

5400	69102055	A30784-03000-5.4M-Black		
5500	69102056	A30784-03000-5.5M-Black		
6000	69102057	A30784-03000-6.0M-Black		
6500	69102058	A30784-03000-6.5M-Black		

图51/FIG. 51 门架(三级全自由)/MAST(FULL FREE 3-STAGE MAST)

FBA30/35-JZ

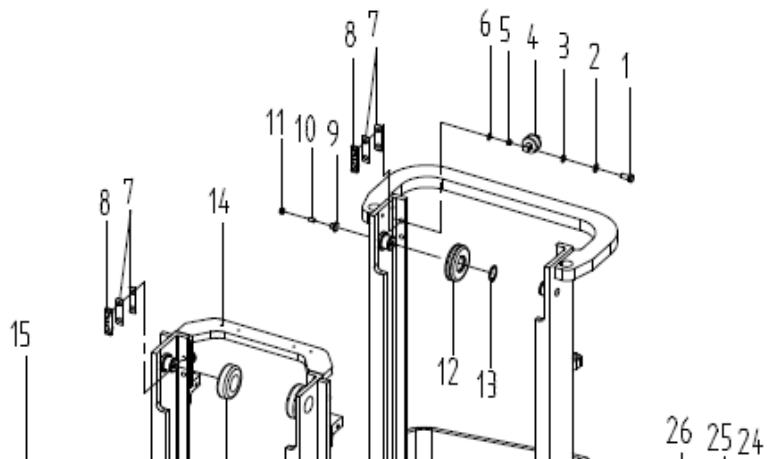

门架选用表 Mast Optional Parts				
起升高度 Lifting Height	物料号	外门架总成 Outer mast	物料号	备注 Remark
	ID.		ID.	
3600	69102238	A35784-05000-3.6M-Black	69102268	
4000	69102239	A35784-05000-4.0M-Black	69102269	
4350	69102240	A35784-05000-4.35M-Black	69102271	
4500	69102241	A35784-05000-4.5M-Black	69102272	
4800	69102242	A35784-05000-4.8M-Black	69102273	
5000	69102243	A35784-05000-5.0M-Black	69102274	
5400	69102244	A35784-05000-5.4M-Black	69102275	
5500	69102245	A35784-05000-5.5M-Black	69102276	
6000	69102246	A35784-05000-6.0M-Black	69102277	

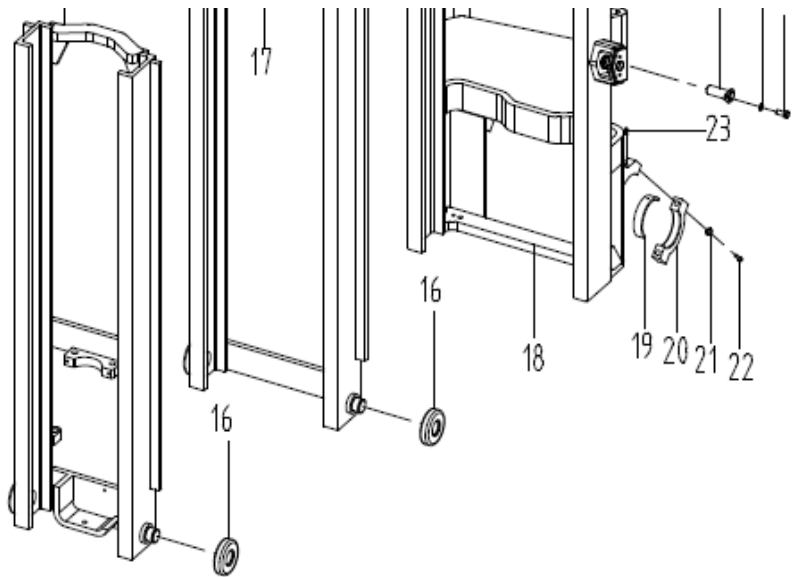

6500	69102247	A35784-05000-6.5M-Black	69102278	

图51/FIG. 51

门架(三级全自由)/MAST(FULL FREE 3-STAGE MAST)

FBA30/35-JZ

门架选用表 Mast Optional Parts

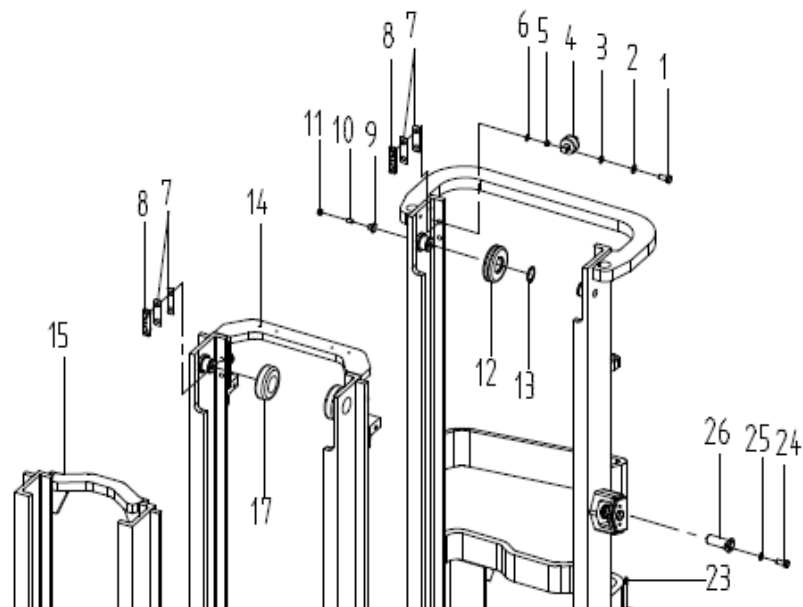

起升高度 Lifting Height	物料号	内门架总成 Inner mast		备注 Remark
	ID.			
3600	69101999	A35784-03000-3.6M-Black		
4000	69102000	A35784-03000-4.0M-Black		
4350	69102001	A35784-03000-4.35M-Black		
4500	69102002	A35784-03000-4.5M-Black		
4800	69102003	A35784-03000-4.8M-Black		
5000	69109000	A35784-03000-5.0M-Black		
5400	69102007	A35784-03000-5.4M-Black		
5500	69102008	A35784-03000-5.5M-Black		
6000	69102009	A35784-03000-6.0M-Black		
6500	69102010	A35784-03000-6.5M-Black		





图52/FIG. 52

起升油缸(基本型)/LIFT CYLINDER(NORMAL MAST)

FBA15/18-JZ

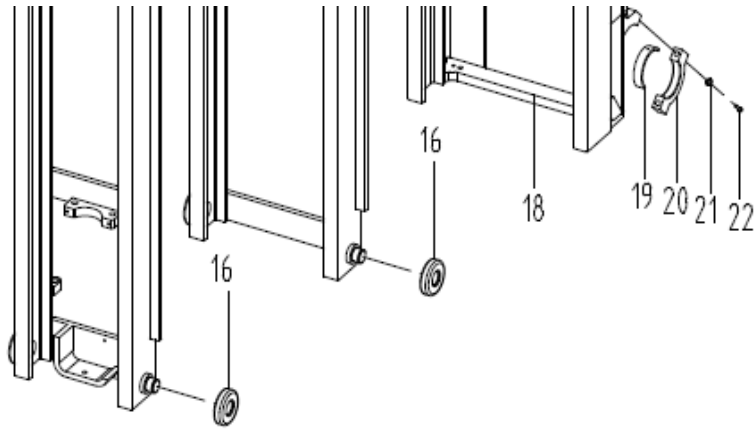
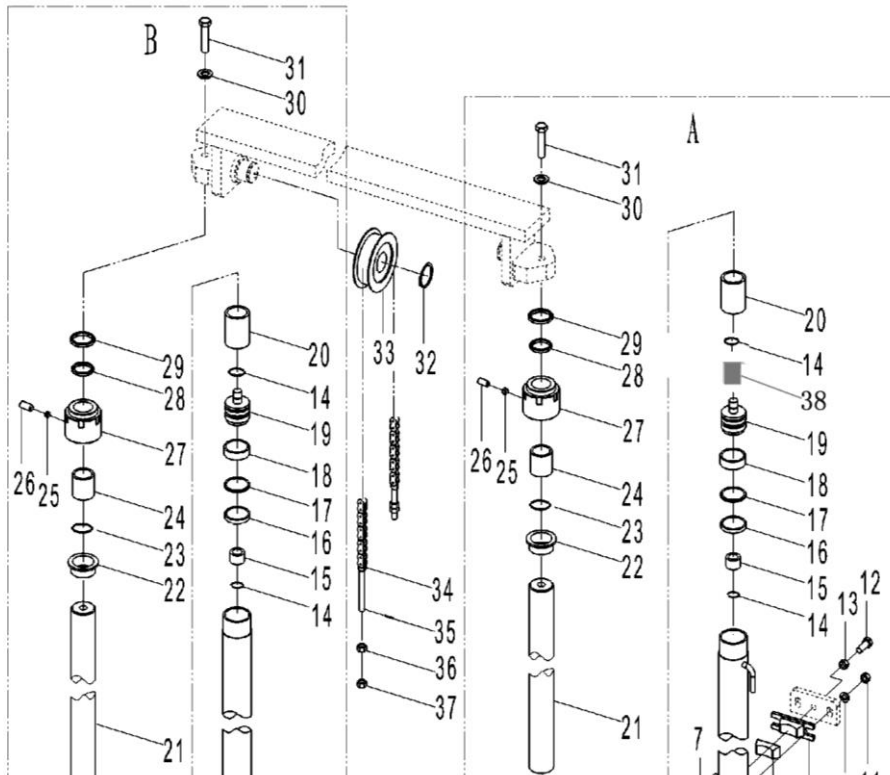

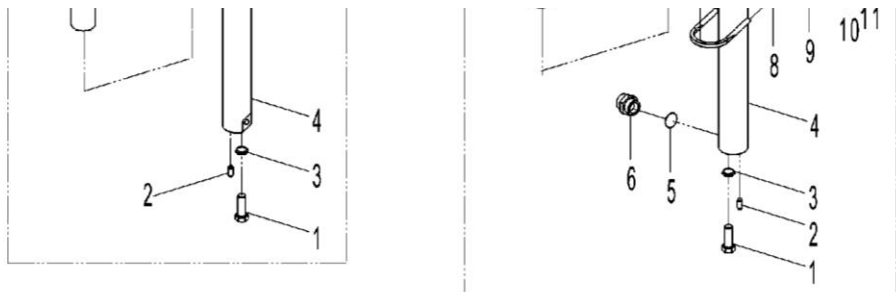
序号	物料号	代号	名称	数量	备注
Item No.	ID.	Part No.	Description	Q'ty	Remark
A	N/A	M1538009000	Lift cylinder(right)	1	
B	N/A	M1538006000	Lift cylinder(left)	1	
1	69000137	GB/T5786-M12*1.25*25-8.8J	Bolt M12×1.25×25	2	
2	69136179	GB119-86	Pin 10×24	2	
3	69000054	GB/T93-12	Washer 12	2	
4	N/A	M152J01-100	Cylinder body	2	
5	69124131	GB1235-22*2.4-G	O-ring 22×2.4	1	
6	69135383	A20480-05100	Safety valve	1	
7	69011293	M1538000005	Hoop	2	
8	69012173	M3038000008	Rubber pad	2	
9	69012172	M1538000007	Hoop seat	2	
10	69000250	GB/T97.1-10	Washer 10	4	
11	69000313	GB/T6171-M10*1.25-8J	Nut M10×1.25	4	
12	69000213	GB/T5786-M12*1.25*30-8.8J	Bolt M12×1.25×30	2	
13	69000314	GB/T6171-M12*1.25-8J	Nut M12×1.25	2	
14	69137593	GB/T895.1-24	Snap spring 24	2	



15	69137579	M1538009001	Sleeve	2	
16	69137583	M1538009002	Packing 45×35×6	2	
17	69135416	A30480-05007	Snap spring φ45×φ35×3	2	
18	69137587	M1538009003	Bush bearing ring D45×8×2.5	2	
19	69137580	M1538009004	Piston	2	
20	69137572	M1538009006	Sleeve φ35×50	按需	
21	N/A	M152J01-1	Piston rod	2	

图52/FIG. 52 起升油缸(基本型)/LIFT CYLINDER(NORMAL MAST)

FBA15/18-JZ

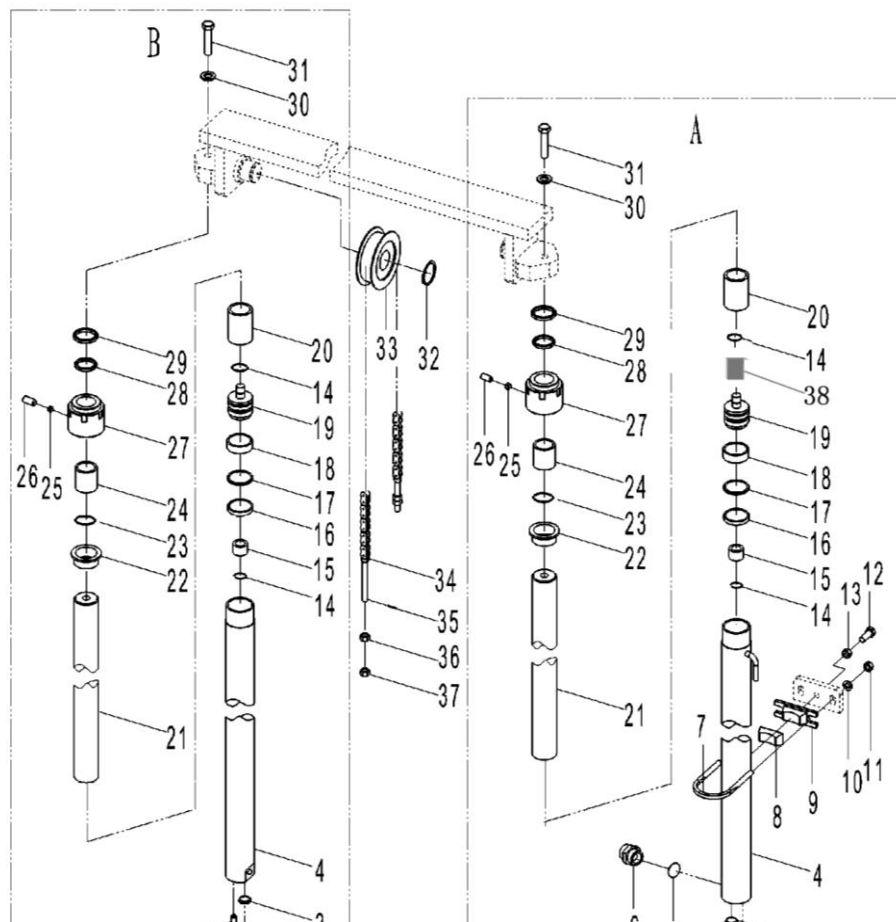

序号	物料号	代号	名称	数量	备注
Item No.	ID.	Part No.	Description	Q'ty	Remark
22	69045601	TLC-15T06	Bushing	2	
23	69137592	GB/T1235-49.7*3.5	O-ring 49.7×3.5	2	
24	69131593	SF-1 35	Bush bearing 35×39×30	2	
25	69135454	A30480-06014	Nylon pad φ6×3	2	
26	69008637	GB/T77-M8*8-12.9J	Bolt M8×8	2	
27	69137578	M1538009005	Cylinder cap	2	
28	69135419	A30480-05010	Packing 35×45×6	2	
29	69137595	M1538009007	Dust-proof seal 35×45×5/6.5	2	
30	69005111	GB/T93-14	Washer 14	2	
31	69033319	GB/T5786-M14*1.5*35-8.8J	Bolt M14×1.5×35	2	
32	69000070	GB/T894.1-Φ40	Snap spring 40	2	
33	69003517	M1538013000	Chain roller 780708K1	2	
34	N/A	M1538001000	Chain ass'y LH1223	2	
35	69137567	GB/T91-3.2*30	Pin 3.2×30	4	
36	69137588	M1538001001	Nut M14×1.5	4	
37	69000316	GB/T6171-M14*1.5-8J	Nut M14×1.5	4	
38	69135384	A20480-05200	One way valve	2	





图52/FIG. 52

起升油缸(基本型)/LIFT CYLINDER(NORMAL MAST)

FBA15/18-JZ

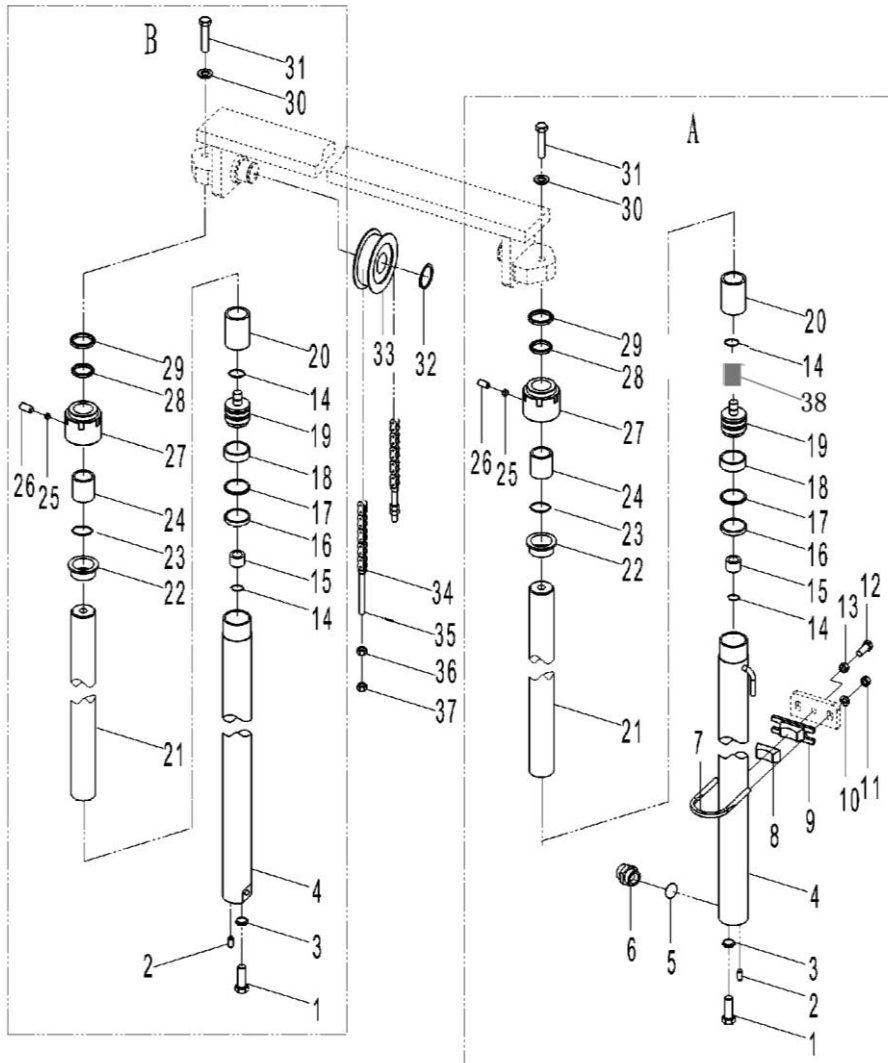

起升油缸选用件(基本型)  
LIFT CYLINDER OPTION TABLE(NOMAL MAST)

起升高度 Lifting g	物料号	链条总成 Chain Ass'y	备注	Remark
	ID.			
3000	69113079	M1538001000-3.0		
3300	69113083	M1538001000-3.3		
3500	69113085	M1538001000-3.5		
3700	69113091	M1538001000-3.7		
4000	69113098	M1538001000-4.0		
4250	69113103	M1538001000-4.25		
4500	69113107	M1538001000-4.5		
4750	69113116	M1538001000-4.75		
5000	69113119	M1538001000-5.0		
5500	69113128	M1538001000-5.5		
6000	69113132	M1538001000-6.0		

图53/FIG. 53

前起升油缸(二级全自由)/FRONT LIFT CYLINDER(FULL FREE 2-STAGE MAST)

FBA15/18-JZ

序号	物料号	代号	名称	数量	备注
----	-----	----	----	----	----

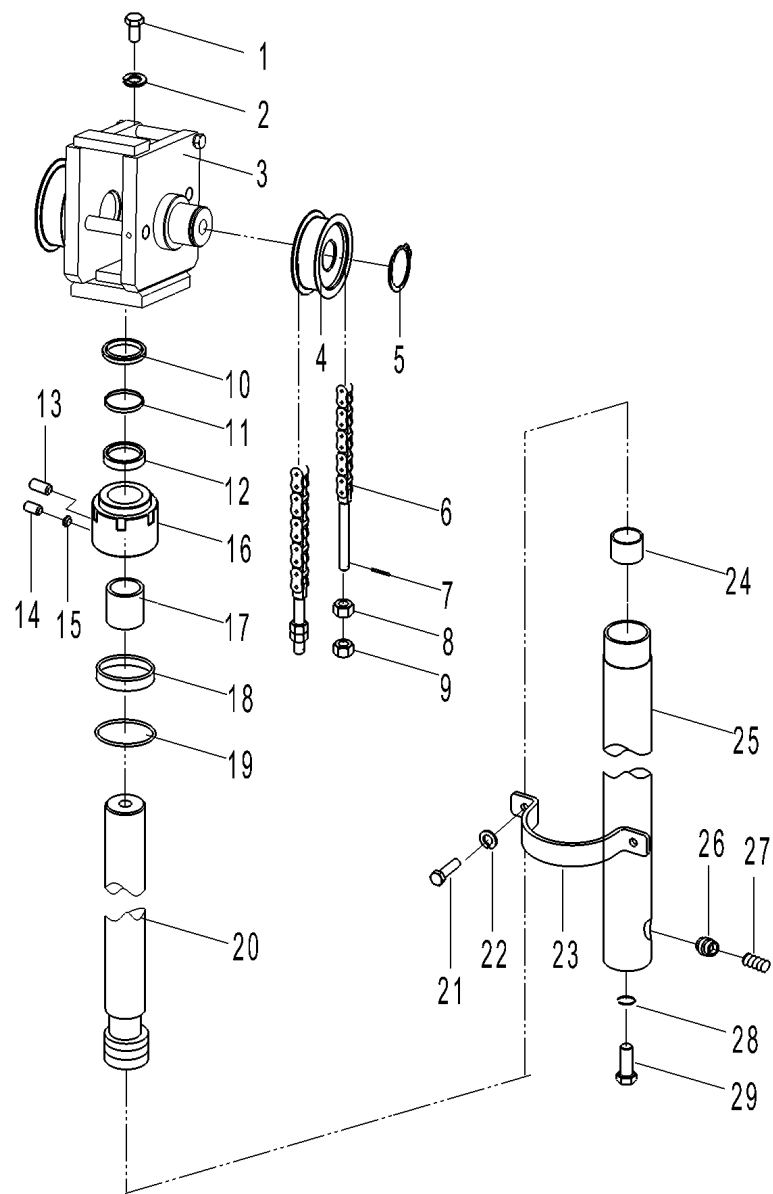

Item No.	ID.	Part No.	Description	Q' ty	Remark
A	N/A	M15043008000	Middle cylinder	1	
1	69000170	GB/T5783-M16*45-8.8J	Bolt M16×1.5×45	1	
2	69000056	GB/T93-16	Washer 16	1	
3	69023541	M15043007000	Roller seat	1	
4	69003517	M1538013000	Chain roller 780708K1	2	
5	69000070	GB/T894.1-Φ40	Snap spring 40	2	
6	N/A	M15043001000	Chain ass'y LH1223	2	
7	69137567	GB/T91-3.2*30	Cotter pin 3.2×30	4	
8	69137588	M1538001001	Spherical nut M14×1.5	4	
9	69000316	GB/T6171-M14*1.5-8J	Nut M14×1.5	4	
10	69137590	M15043008001	Dust-proof seal 70×80×6/8	1	
11	69135707	MJ30384-03006	Snap spring d70×Φ80×3	1	
12	69135709	MJ30384-03008	Axis seal 70×80×6	1	
13	69137570	M15043008002	Plug ZG1/4"	1	
14	69137568	GB/T80-M8*10	Plug M8×10	1	
15	69135454	A30480-06014	Nylon pad Φ6×3	1	
16	69137578	M1538009005	Cylinder cap	1	
17	69137581	M15043008003	Bush bearing 70×75×30	1	
18	69137589	M15043008004	Snap spring d89×Φ94×2	1	
19	69022538	GB/T3452.1-90*3.55	O-ring 90×3.55	1	
20	N/A	M152J05-200A	Piston rod	1	
21	69000123	GB/T5783-M10*20-8.8J	Bolt M10×20	2	
22	69000053	GB/T93-10	washer 10	2	
23	69106448	M15043000001-Black	Hold hoop	1	
24	69137585	M15043008005	Bush bearing ring D80×25×3	1	

图53/FIG. 53

前起升油缸(二级全自由)/FRONT LIFT CYLINDER(FULL FREE 2-STAGE MAST)

FBA15/18-JZ

序号	物料号	代号	名称	数量	备注
Item No.	ID.	Part No.	Description	Q' ty	Remark

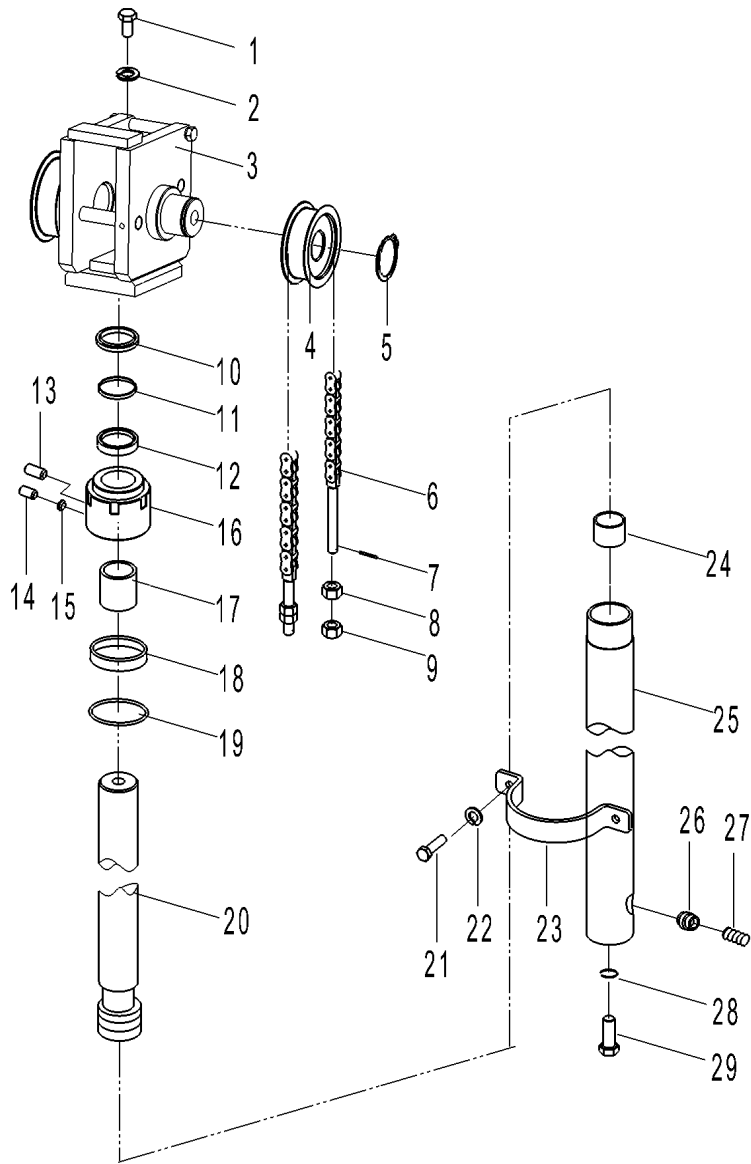

25	N/A	M152J05-100	Cylinder body	1	
26	69136236	TLC-15T12	Safety valve	1	
27	69072588	TLC-15T13	Spring	1	
28	69000054	GB/T93-12	Washer 12	1	
29	69000137	GB/T5786-M12*1.25*25-8.8J	Bolt M12×1.25×25	1	

图53/FIG. 53

前起升油缸(二级全自由)/FRONT LIFT CYLINDER(FULL FREE 2-STAGE MAST)

FBA15/18-JZ

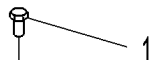

前起升缸选用件(二级全自由门架)  
FRONT LIFT CYLINDER OPTIONAL PARTS (FULL FREE 2-STAGE MAST)

起升高 度	物料号	前起升油缸	物料号	备注

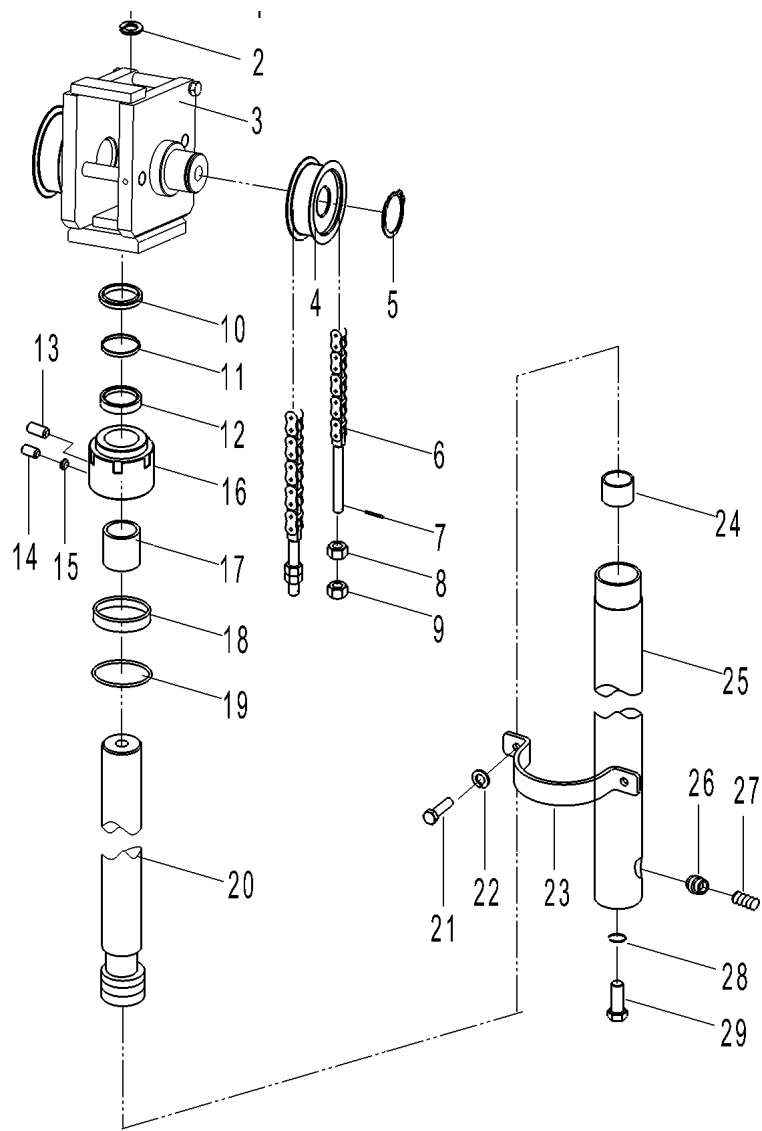

Lifting	ID.	Lift cylinder	ID.	Remark
3000	69005371	M15043008000-3.0M	69114101	
3300	69006449	M15043008000-3.3M	69114102	
3500	69048144	M15043008000-3.5M	69114103	
3700	69048145	M15043008000-3.7M	69114104	
4000	69048146	M15043008000-4.0M	69114105	
4500	69048147	M15043008000-4.5M	69114106	
5000	69048149	M15043008000-5.0M	69114107	
5500	69048148	M15043008000-5.5M	69114108	
6000	69048150	M15043008000-6.0M	69114109	

图54/FIG. 54 后起升油缸(二级全自由)/REAR LIFT CYLINDER(FULL FREE 2-STAGE MAST)

FBA15/18-JZ

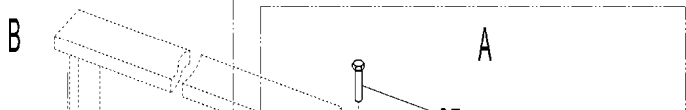

序号	物料号	代号	名称	数量	备注
Item No.	ID.	Part No.	Description	Q' ty	Remark
A	N/A	M15043006000	Lift cylinder(right)	1	
B	N/A	M15043003000	Lift cylinder(left)	1	

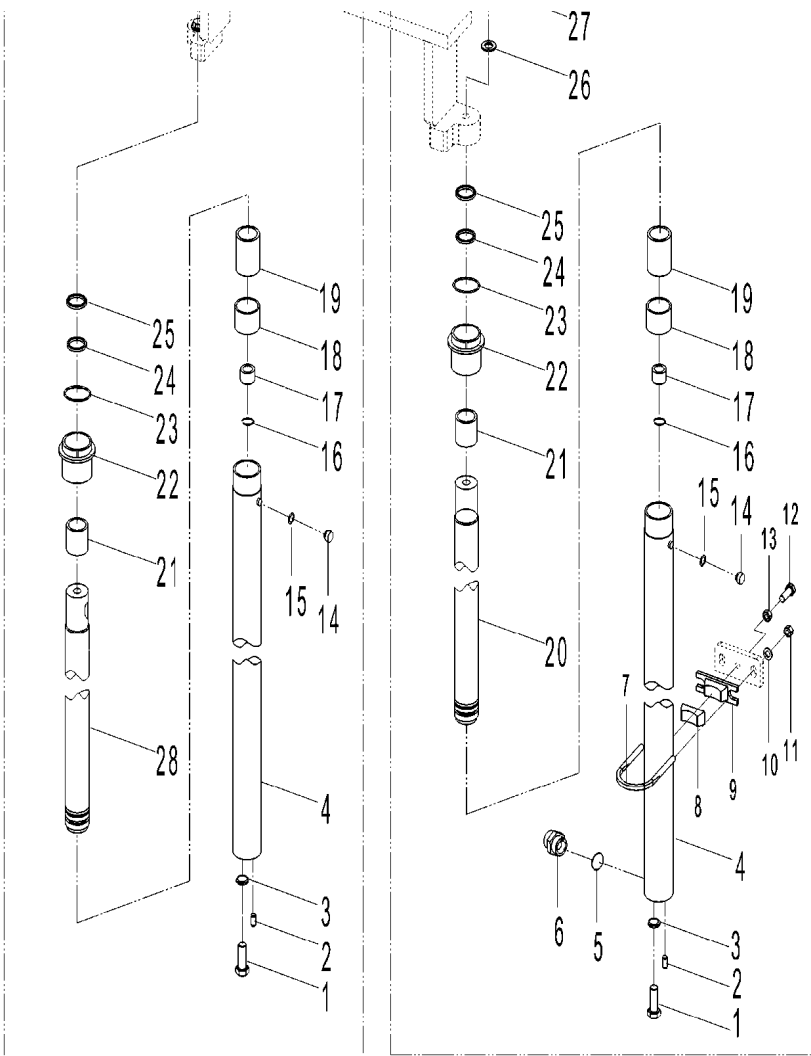

01	69000137	GB/T5786-M12*1.25*25-8.8J	Bolt M12×1.25×25	2	
02	69000337	GB/T119.2-Φ10*25	Pin 10×25	2	
03	69000054	GB/T93-12	Washer 12	2	
04	N/A	M152J03-200	Cylinder body	2	
05	69124131	GB1235-22*2.4-G	O-ring 22×2.4	1	
06	69135383	A20480-05100	Safety valve	1	
07	69011293	M1538000005	Hoop	2	
08	69012173	M3038000008	Rubber pad	2	
09	69012172	M1538000007	Hoop seat	2	
10	69000250	GB/T97.1-10	Washer 10	4	
11	69000313	GB/T6171-M10*1.25-8J	Nut M10×1.25	4	
12	69000213	GB/T5786-M12*1.25*30-8.8J	Bolt M12×1.25×30	2	
13	69000314	GB/T6171-M12*1.25-8J	Nut M12×1.25	2	
14	69135575	M30043005010	Deflate plug M8	2	
15	69094104	JB982-77	Seal ring 8	2	
16	69137591	GB/T895.1-22	Snap spring 22	2	
17	69137576	M15043006001	Sleeve	2	
18	69137586	M15043006002	Bearing ring D45×24×3	2	
19	69137575	M15043006003	Sleeve φ32×100	2	
20	N/A	M152J04-100A	Piston rod(right)	1	
21	69137582	M15043006004	Bush bearing 32×36×30	2	
22	69137574	M15043006005	Cylinder cap	2	
23	69022446	GB/T1235-50*3.1	O-ring 50×3.1	2	

图54/FIG. 54

后起升油缸(二级全自由)/REAR LIFT CYLINDER(FULL FREE 2-STAGE MAST)

FBA15/18-JZ

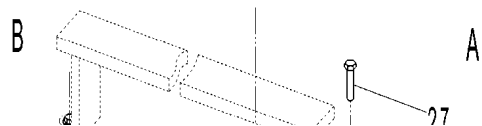

序号	物料号	代号	名称	数量	备注
Item No.	ID.	Part No.	Description	Q'ty	Remark
24	69135347	A20480-04007	Axis seal 32×42×6	2	
25	69135349	A20480-04009	Dust-proof seal 32×40×5/6	2	
26	69000056	GB/T93-16	Washer 16	2	

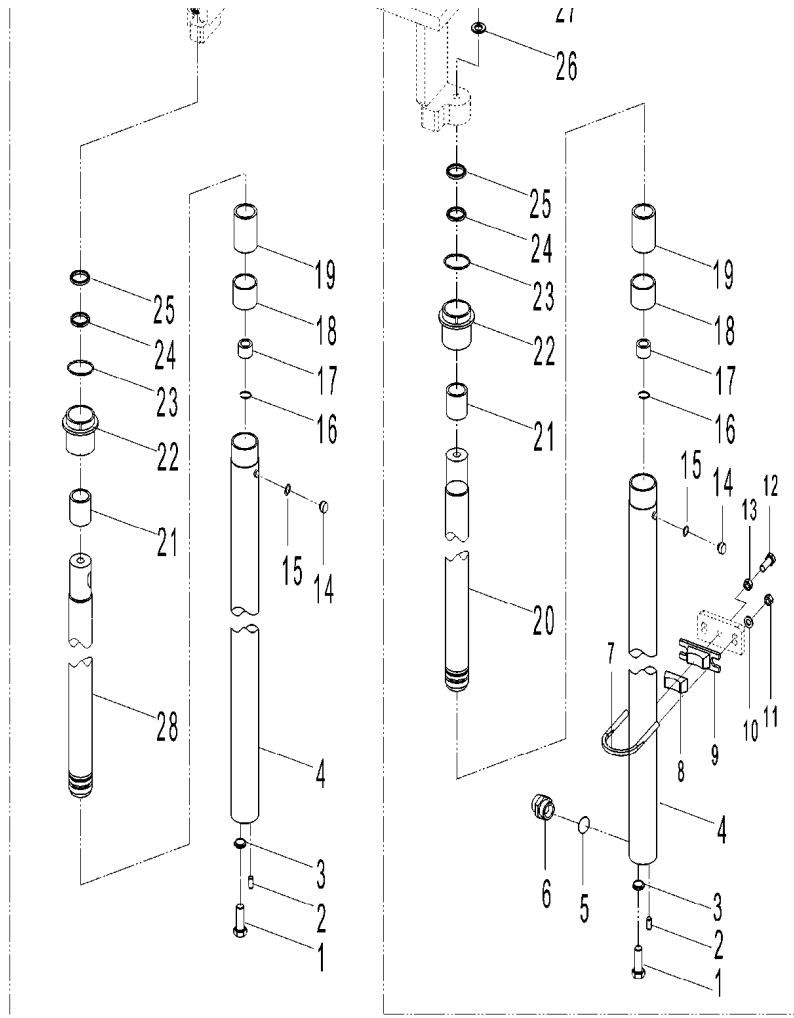

27	69006551	GB/T5783-M16*40-8.8J	Bolt M16×40	2	
28	N/A	M152J03-100A	Piston rod(left)	1	

图54/FIG. 54

后起升油缸(二级全自由)/REAR LIFT CYLINDER(FULL FREE 2-STAGE MAST)

FBA15/18-JZ

1.5-1.8t起升油缸选用表(二级全自由)  
LIFT CYLINDER OPTION TABLE(FULL FREE 2-STAGE MAST ZM)

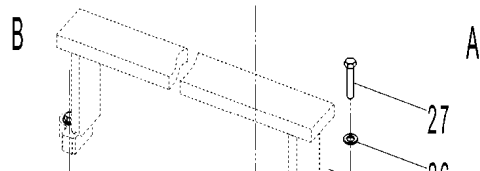

起升高度 Lifting Height	物料号	1.5-1.8t左起升油缸 Lift cylinder L.H.	物料号	备注 Remark
	ID.		ID.	
3000	69006869	M15043003000-3.0M	69102434	
3300	69002875	M15043003000-3.3M	69102417	

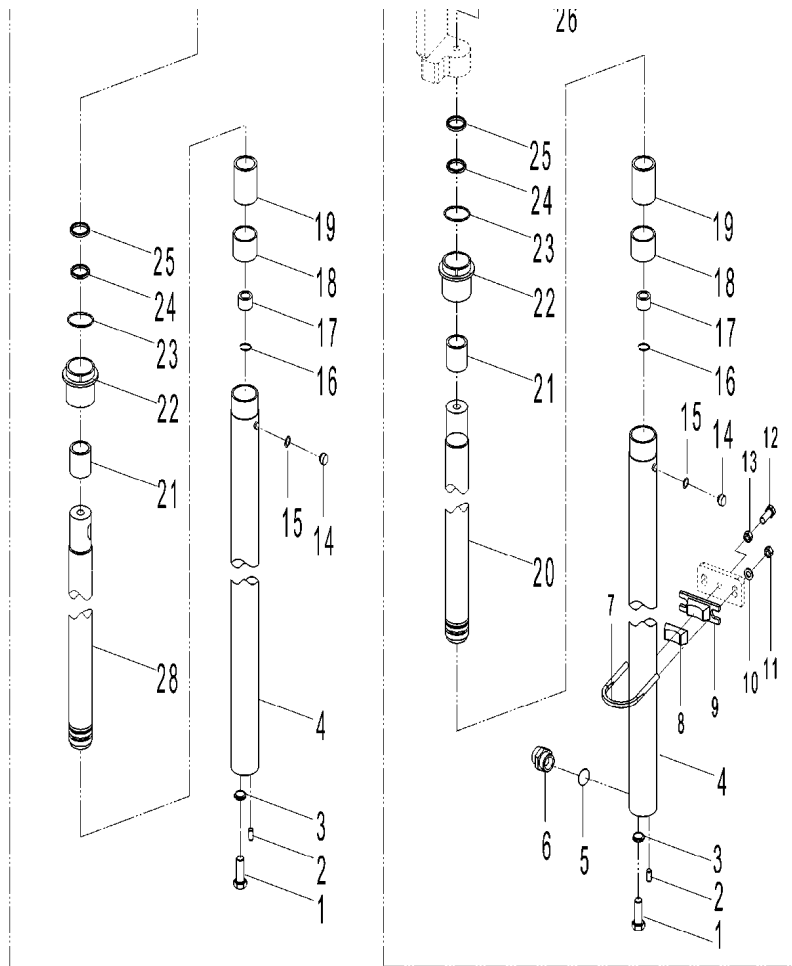

3500	69008482	M15043003000-3.5M	69102448	
3700	69048137	M15043003000-3.7M	69103571	
4000	69048138	M15043003000-4.0M	69103572	
4500	69048139	M15043003000-4.5M	69103573	
5000	69048140	M15043003000-5.0M	69103574	
5500	69018411	M15043003000-5.5M	69103566	
6000	69048141	M15043003000-6.0M	69103575	

图55/FIG. 55 前起升油缸(三级全自由)/FRONT LIFT CYLINDER(FULL FREE 3-STAGE MAST)

FBA15/18-JZ

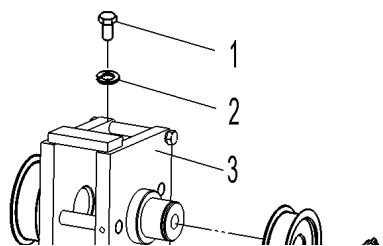

序号 Item No.	物料号 ID.	代号 Part No.	名称 Description	数量 Q'ty	备注 Remark
A	N/A	M15074009000	Middle cylinder	1	(Max153J03)
1	69000170	GB/T5783-M16*45-8.8J	Bolt M16×45	1	
2	69000056	GB/T93-16	Washer 16	1	
3	69014888	M15074008000	Roller seat	1	
4	69003517	M1538013000	Chain roller 780708K1	2	

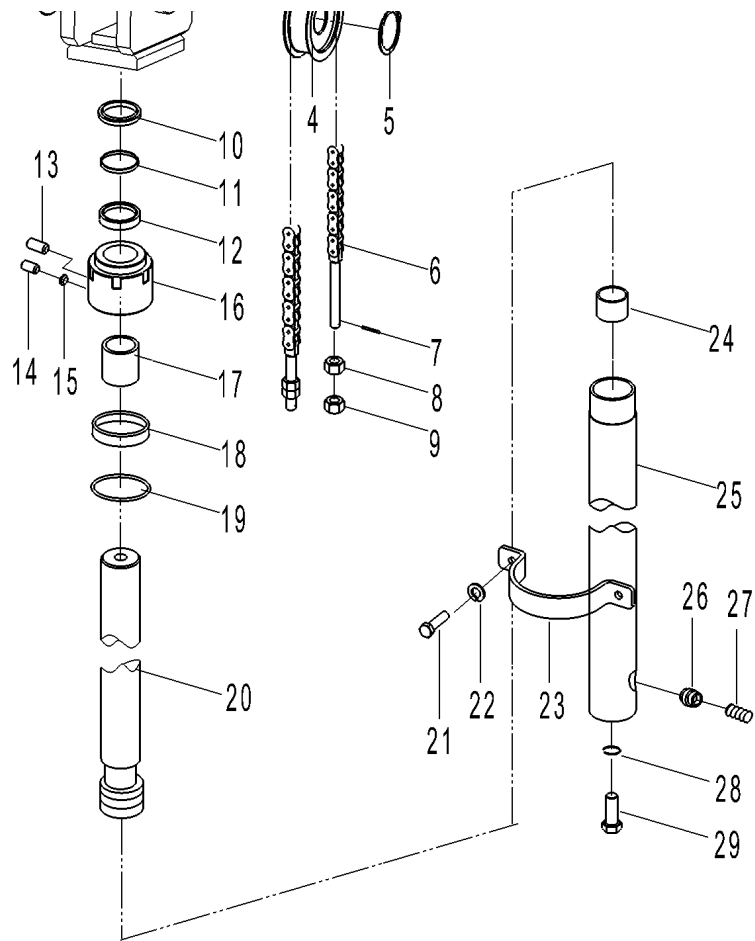

5	69000070	GB/T894.1-Φ40	Snap spring 40	2	
6	N/A	A15784-04000	Chain ass'y LH1223	2	
7	69137567	GB/T91-3.2*30	Cotter pin 3.2×30	2	
8	69137588	M1538001001	Nut M14×1.5	4	
9	69000316	GB/T6171-M14*1.5-8J	Nut M14×1.5	4	
10	69137590	M15043008001	Dust-proof seal 70×80×6/8	1	
11	69135707	MJ30384-03006	Snap spring d70×φ80×3	1	
12	69135709	MJ30384-03008	Axis seal 70×80×6	1	
13	69137570	M15043008002	Plug ZG1/4"	1	
14	69008637	GB/T77-M8*8-12.9J	Hexagon bolt M8×8	1	内六角
15	69135454	A30480-06014	Nylon pad φ6×3	1	
16	69047957	TLC-15T09	Cylinder cap	1	
17	69137581	M15043008003	Bush bearing 70×75×30	1	
18	69137589	M15043008004	Snap spring d89×φ94×2	1	
19	69022538	GB/T3452.1-90*3.55	O-ring 90×3.55	1	
20	N/A	Max153J03-200A	Piston rod	1	
21	69032087	GB/T5786-M10*1.25*20-8.8J	Bolt M10×1.25×20	2	
22	69000053	GB/T93-10	Washer 10	2	
23	69112801	M15074000001-Black	Hold hoop	1	
24	69137585	M15043008005	Bearing ring D80×25×3	1	

图55/FIG. 55

前起升油缸(三级全自由)/FRONT LIFT CYLINDER(FULL FREE 3-STAGE MAST)

FBA15/18-JZ

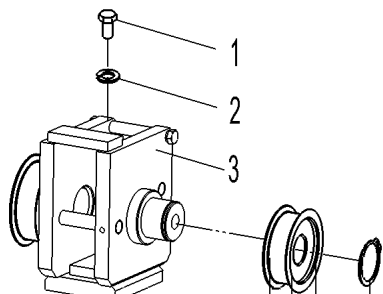

序号	物料号	代号	名称	数量	备注
Item No.	ID.	Part No.	Description	Q'ty	Remark
25	N/A	Max153J03-100	Cylinder body	1	
26	69136236	TLC-15T12	Safety valve	1	
27	69072588	TLC-15T13	Spring	1	
28	69000137	GB/T5786-M12*1.25*25-8.8J	Bolt M12×1.25×25	1	
29	69000054	GB/T93-12	Washer 12	1	







图55/FIG. 55 前起升油缸(三级全自由)/FRONT LIFT CYLINDER(FULL FREE 3-STAGE MAST)

FBA15/18-JZ

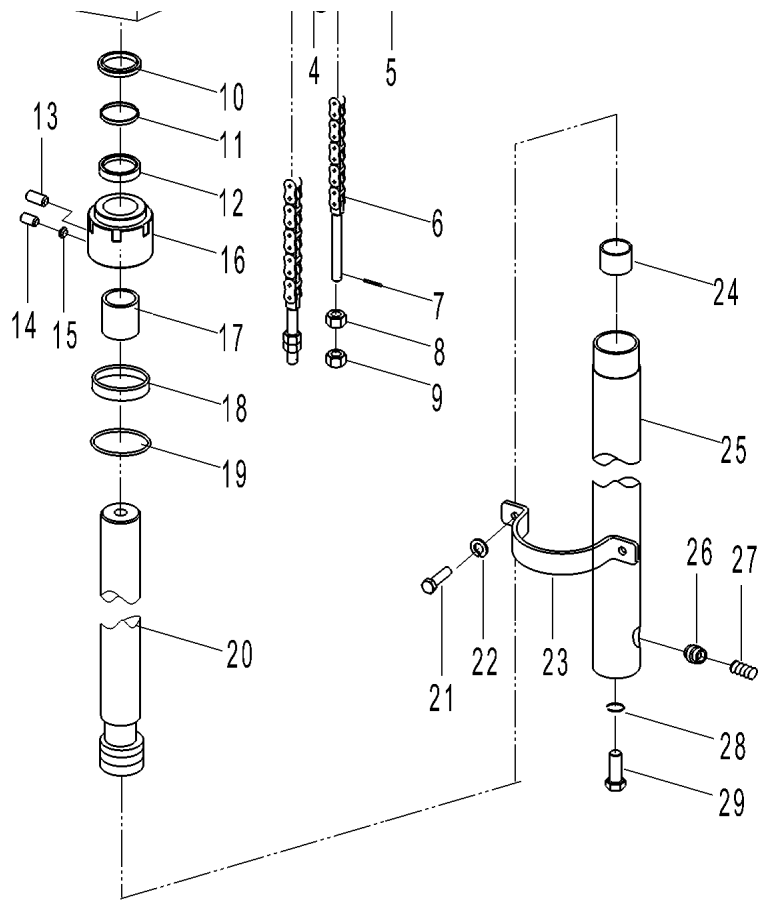
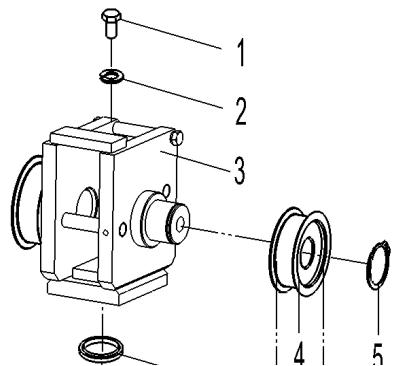

前起升油缸选用表  
FRONT LIFT CYLINDER OPTION TABLE

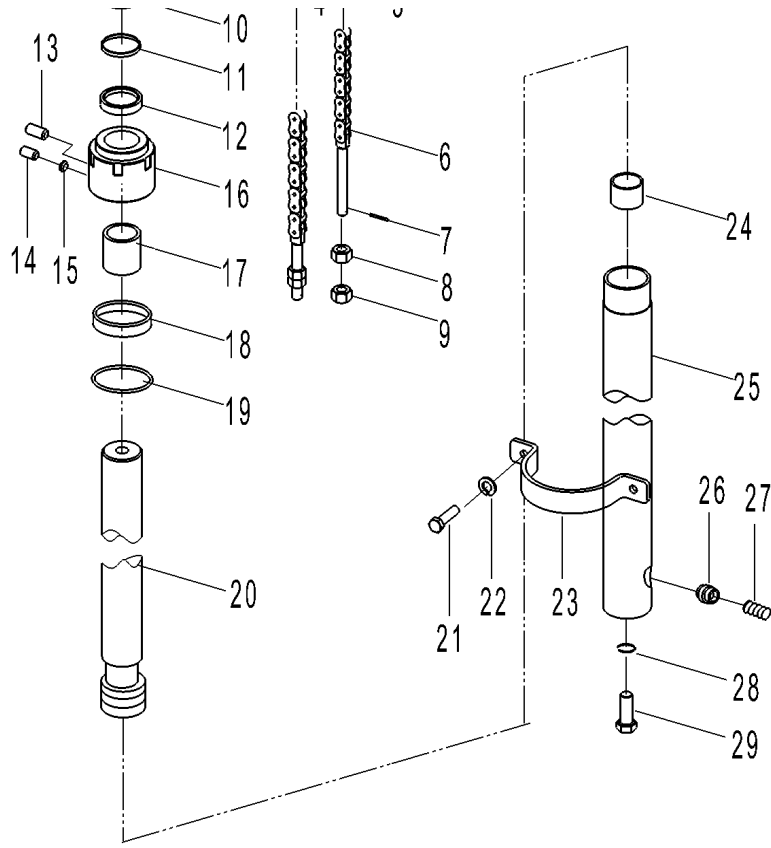
起升高度 Lifting Height	物料号	前起升油缸 Lift cylinder	物料号	(短) 链条总成 Chain	备注 Remark
	ID.		ID.		
3600	69048420	M15074009000-3.6M	69116415	A15784-04000-	
4000	69049734	M15074009000-4.0M	69116416	A15784-04000-	标准
4350	69012039	M15074009000-4.35M	69116417	A15784-04000-	
4500	69002989	M15074009000-4.5M	69116418	A15784-04000-	
4800	69004873	M15074009000-4.8M	69116419	A15784-04000-	



5000	69002991	M15074009000-5.0M	69116421	A15784-04000-	
5500	69002974	M15074009000-5.5M	69116422	A15784-04000-	
6000	69007950	M15074009000-6.0M	69116423	A15784-04000-	

图56/FIG. 56

后起升油缸(三级全自由)/REAR LIFT CYLINDER(FULL FREE 3-STAGE MAST)

FBA15/18-JZ

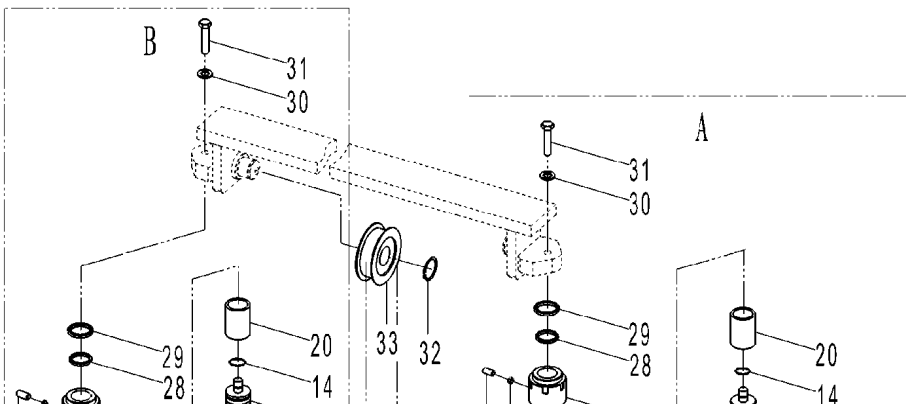

序号 Item No.	物料号 ID.	代号 Part No.	名称 Description	数量 Q'ty	备注 Remark
A	N/A	M15074006000	Lift cylinder(right)	1	
B	N/A	M15074007000	Lift cylinder(left)	1	
1	69000137	GB/T5786-M12*1.25*25-8.8J	Bolt M12×1.25×25	2	
2	69000337	GB/T119.2-Φ10*25	Pin 10×24	1	
3	69000054	GB/T93-12	Washer 12	2	
4	N/A	Max153J02-100	Cylinder body(right)	1	
5	69124131	GB1235-22*2.4-G	O-ring 22×2.4	1	
6	69135383	A20480-05100	Safety valve	1	

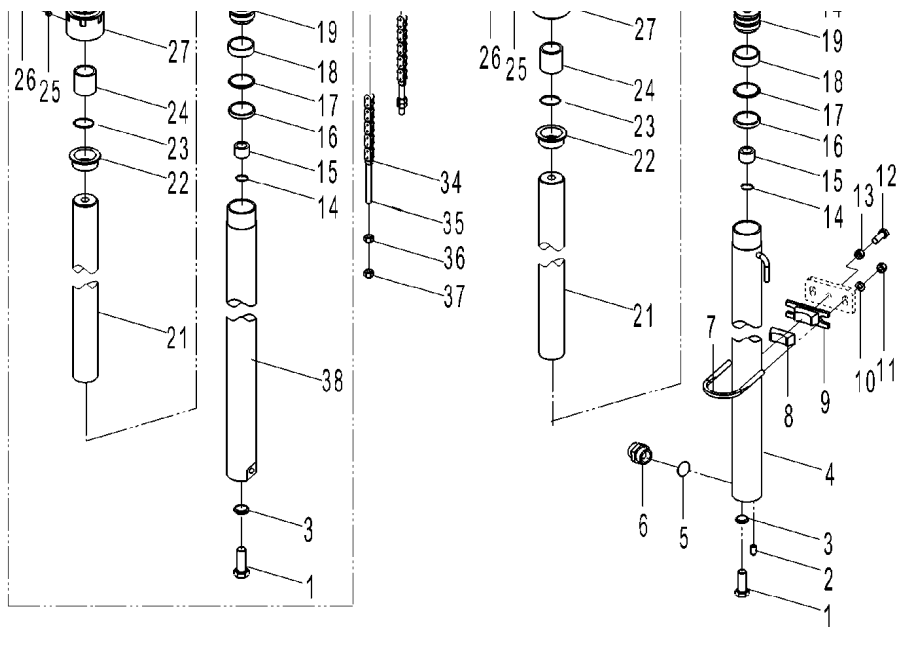

7	69011293	M1538000005	Hoop	2	
8	69012173	M3038000008	Rubber pad	2	
9	69012172	M1538000007	Hoop seat	2	
10	69000250	GB/T97.1-10	Washer 10	4	
11	69000313	GB/T6171-M10*1.25-8J	Nut M10×1.25	4	
12	69000213	GB/T5786-M12*1.25*30-8.8J	Bolt M12×1.25×30	2	
13	69000314	GB/T6171-M12*1.25-8J	Nut M12×1.25	2	
14	69137593	GB/T895.1-24	Snap spring d=24	4	
15	69137579	M1538009001	Sleeve	2	
16	69137583	M1538009002	Packing 45×35×6	2	
17	69135416	A30480-05007	Snap spring φ45×φ35×3	2	
18	69137587	M1538009003	Bush bearing ring D45×8×2.5	2	
19	69137580	M1538009004	Piston	2	
20	69137584	M15074006001	Sleeve	2	
21	N/A	Max153J01-1	Piston rod	2	
22	69045601	TLC-15T06	Bushing	2	
23	69023163	GB/T1235-55*3.1	O-ring 55×3.1	2	

图56/FIG. 56

后起升油缸(三级全自由)/REAR LIFT CYLINDER(FULL FREE 3-STAGE MAST)

FBA15/18-JZ

序号	物料号	代号	名称	数量	备注
Item No.	ID.	Part No.	Description	Q'ty	Remark
24	69131593	SF-1 35	Bush bearing 35×39×30	2	
25	69135454	A30480-06014	Nylon pad φ6×3	2	
26	69136178	GB77-85	Bolt M8×8	2	
27	69137578	M1538009005	Cylinder cap	2	
28	69137594	M15074006002	Packing 35×45×7	2	
29	69135550	M20043005006	Dust-proof seal 35×47×7/10	2	
30	69000056	GB/T93-16	Washer 16	2	
31	69000184	GB/T5786-M16*1.5*35	Bolt M16×1.5×35	2	
32	69000070	GB/T894.1-Φ40	Snap spring 40	2	

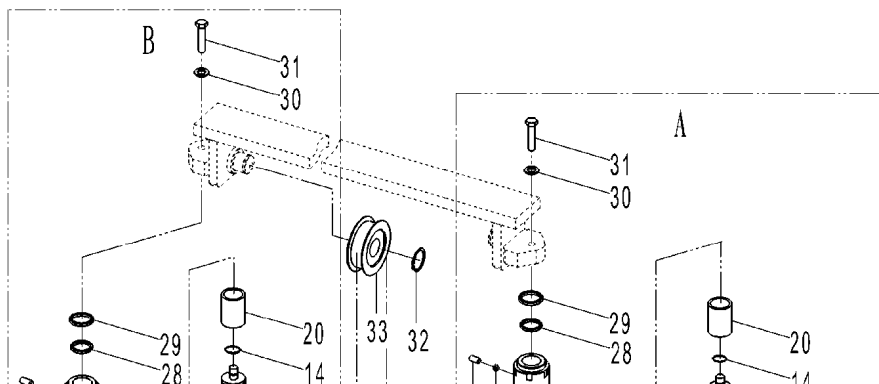

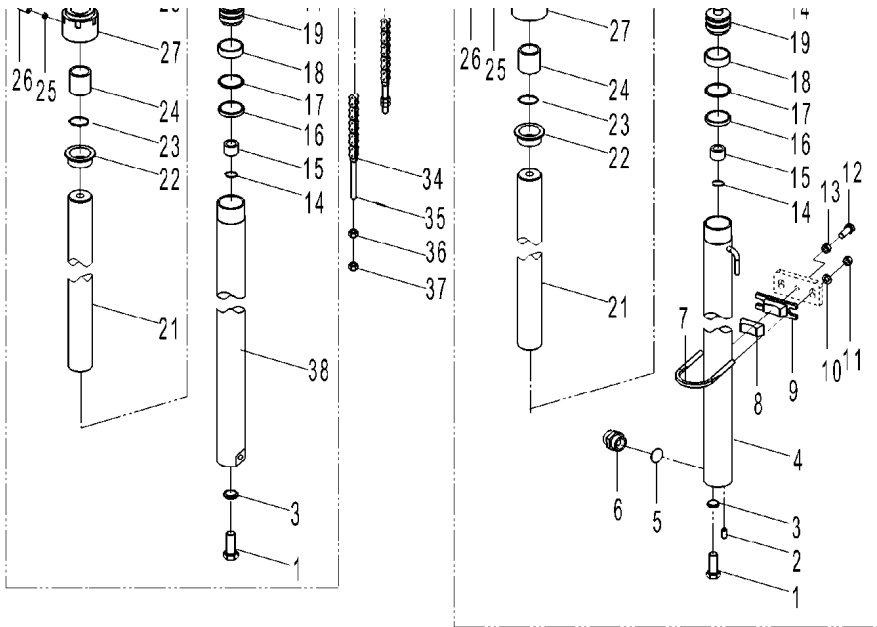

33	69003517	M1538013000	Chain roller 780708K1	2	
34	N/A	A15784-01000	Chain ass'y LH1223	2	
35	69137567	GB/T91-3.2*30	Cotter pin 3.2×30	4	
36	69137588	M1538001001	Nut M14×1.5	4	
37	69000316	GB/T6171-M14*1.5-8J	Nut M14×1.5	4	
38	N/A	Max153J01-100	Cylinder body(left)	1	

图56/FIG. 56 后起升油缸(三级全自由)/REAR LIFT CYLINDER(FULL FREE 3-STAGE MAST)

FBA15/18-JZ

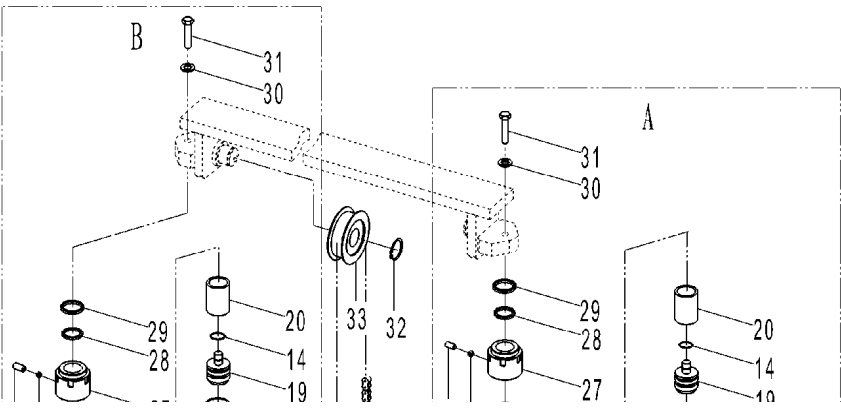

起升油缸选用表  
LIFT CYLINDER OPTION TABLE

起升高度 Lifting Height	物料号	起升油缸左 Lift cylinder L.H.	物料号	起升油缸右 Lift cylinder R.H.	备注 Remark
	ID.		ID.		
3600	69048418	M15074007000-3.6M	69104787	74006000	
4000	69048416	M15074007000-4.0M	69103504	74006000	
4350	69012038	M15074007000-4.35M	69102891	74006000	
4500	69006381	M15074007000-4.5M	69102427	74006000	
4800	69004872	M15074007000-4.8M	69102423	74006000	
5000	69007649	M15074007000-5.0M	69102436	74006000	
5500	69002878	M15074007000-5.5M	69102419	74006000	
6000	69007651	M15074007000-6.0M	69102437	74006000	





图56/FIG. 56 后起升油缸(三级全自由)/REAR LIFT CYLINDER(FULL FREE 3-STAGE MAST)

FBA15/18-JZ

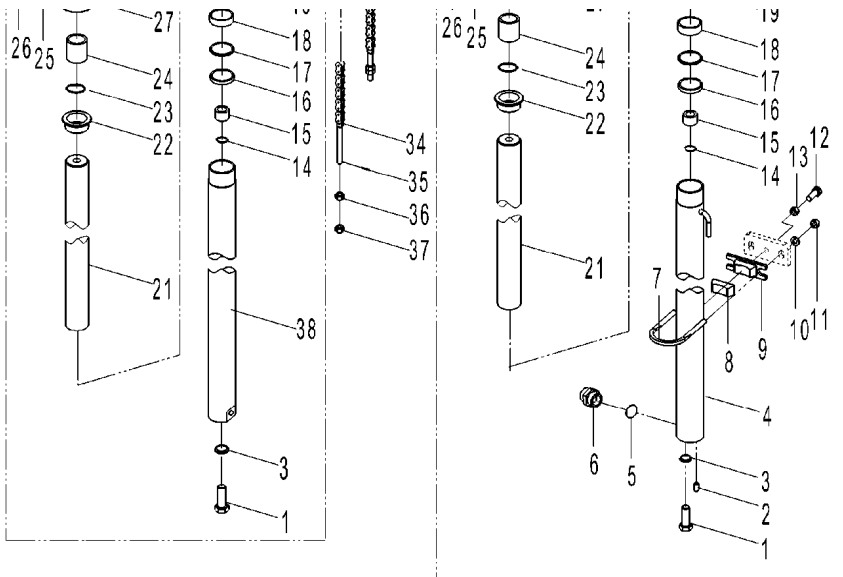
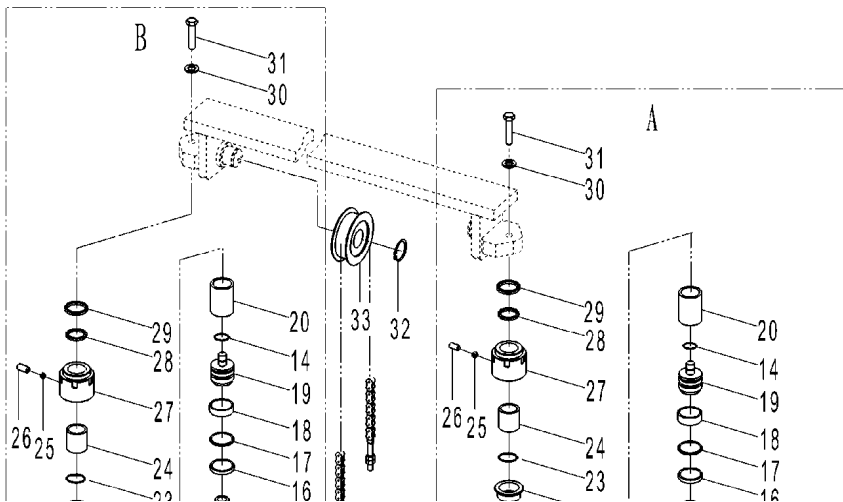

起升油缸选用表  
LIFT CYLINDER OPTION TABLE

起升高度 Lifting Height	物料号	(长) 链条总成 Chain Ass'y			备注 Remark
	ID.				
3600	69116407	A15784-01000-3.6			
4000	69116408	A15784-01000-4.0			
4350	69116409	A15784-01000-4.35			
4500	69116410	A15784-01000-4.5			
4800	69116411	A15784-01000-4.8			
5000	69116412	A15784-01000-5.0			
5500	69116413	A15784-01000-5.5			
6000	69116414	A15784-01000-6.0			





图57/FIG. 57 起升油缸(基本型)/LIFT CYLINDER(NORMAL MAST)

FBA20/25/30/35-JZ

序号 Item No.	物料号 ID.	代号 Part No.	名称 Description	数量 Q' ty	备注 Remark
A	N/A	A20480-05000	Lift cylinder(right)	1	FBA20/25-JZ
-	N/A	A30480-06000	Lift cylinder(right)	1	FBA30-JZ
-	N/A	A35484-04000	Lift cylinder(right)	1	FBA35-JZ
B	N/A	A20480-06000	Lift cylinder(left)	1	FBA20/25-JZ
-	N/A	A30480-07000	Lift cylinder(left)	1	FBA30-JZ
-	N/A	A35480-05000	Lift cylinder(left)	1	FBA35-JZ
1	69000137	GB/T5786-M12*1.25*25-8.8J	Bolt M12×1.25×25	2	
2	69000337	GB/T119. 2-Φ10*25	Cylindrical pin 10×25	2	
3	69000054	GB/T93-12	Washer 12	2	
4	N/A	Max202J01A-100	Cylinder body	2	FBA20/25-JZ
-	N/A	Max302J01A-100	Cylinder body	2	FBA30-JZ
-	N/A	Max352J01A-100	Cylinder body	2	FBA35-JZ
5	69124131	GB1235-22*2.4-G	O-ring 22×2.4	1	FBA20/25/30-JZ
-	69124132	GB1235-30*3.5-G	O-ring 30×3.5	1	FBA35-JZ

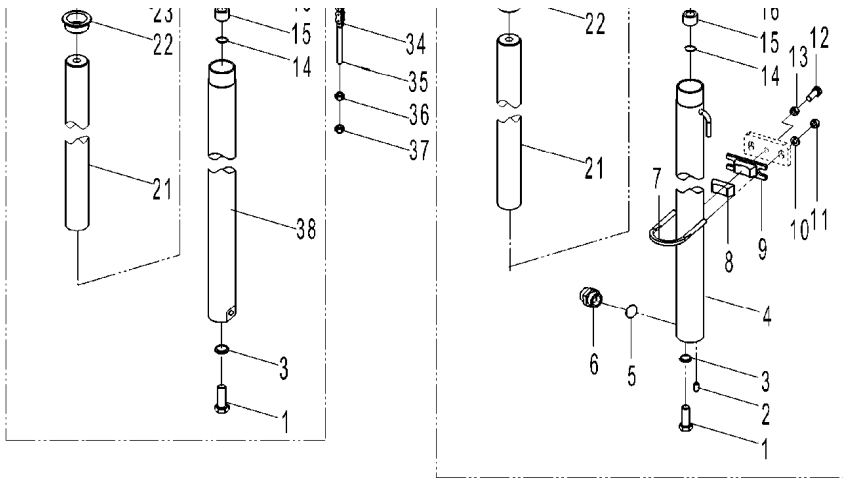
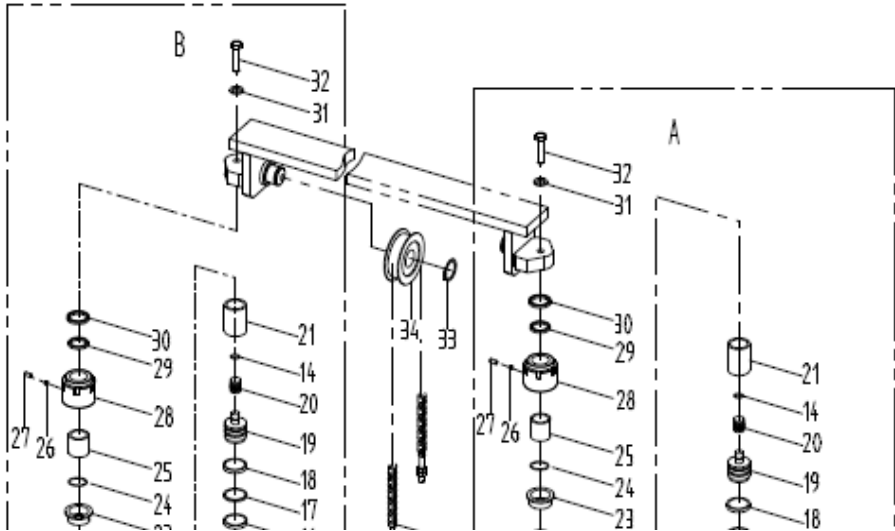
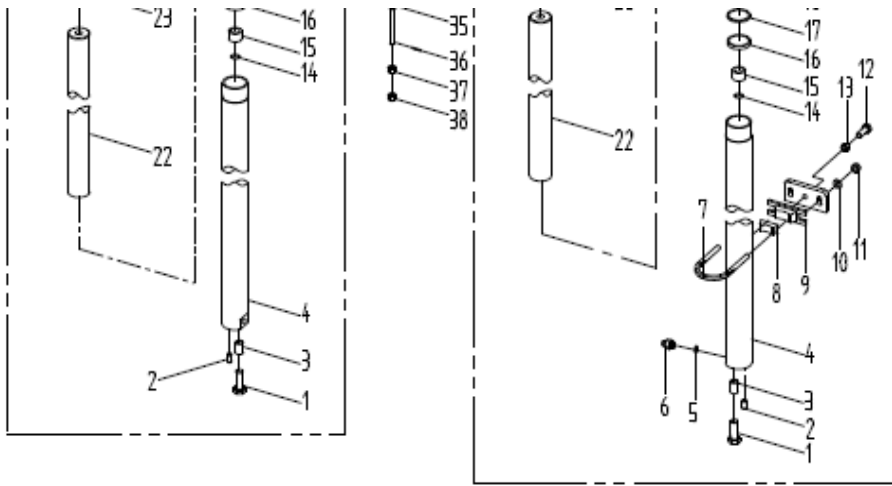



6	69135383	A20480-05100	Safety valve	1	FBA20/25-JZ
-	69135455	A30480-06100	Safety valve	1	FBA30-JZ
-	69135512	A35480-04100	Safety valve	1	FBA35-JZ
7	69006791	M3038000007	Hoop	2	FBA20/25/30-JZ
-	69009408	M3538000001	Hoop	2	FBA35-JZ
8	69012173	M3038000008	Rubber pad	2	FBA20/25/30-JZ
-	69012173	M3038000008	Rubber pad	2	FBA35-JZ
9	69012171	M3038009000	Hoop seat	2	FBA20/25/30-JZ
-	69012170	M3538000002	Hoop seat	2	FBA35-JZ
10	69000250	GB/T97. 1-10	Washer 10	4	
11	69000313	GB/T6171-M10*1. 25-8J	Nut M10×1. 25	4	

图57/FIG. 57

起升油缸(基本型)/LIFT CYLINDER(NORMAL MAST)

FBA20/25/30/35-JZ

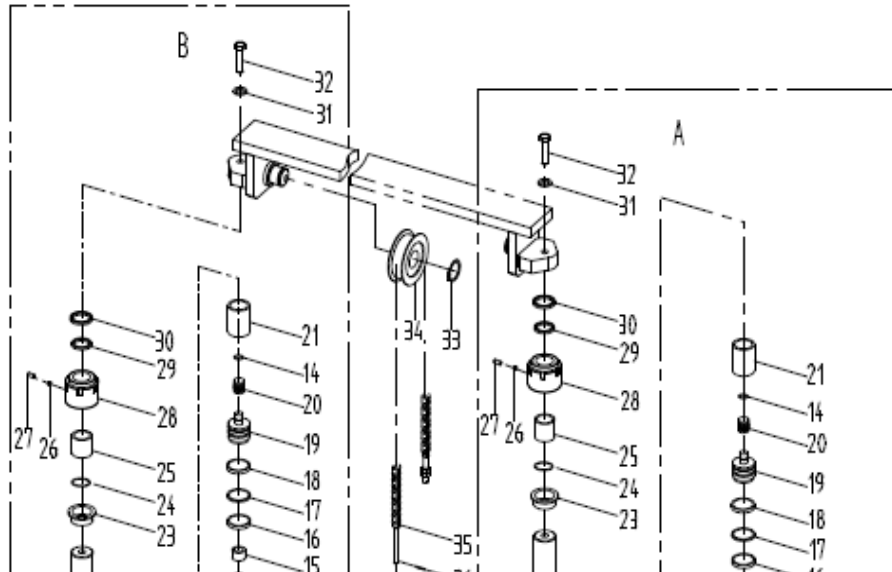

序号	物料号	代号	名称	数量	备注
Item No.	ID.	Part No.	Description	Q'ty	Remark
12	69000139	GB/T5786-M12*1. 25*40-8. 8J	Bolt M12×1. 25×45	2	
13	69000314	GB/T6171-M12*1. 25-8J	Nut M12×1. 25	2	
14	69130898	GB/895. 1-30	Snap spring 30	4	FBA20/25/30-JZ
-	69133213	M452J01-5	Snap spring 35	4	FBA35-JZ
15	69136215	TLC-30T03A	Sleeve	2	FBA20/25/30-JZ
-		D5A000-15E01-5	Sleeve	2	FBA35-JZ
16	69135377	A20480-05008	Packing 50×40×6	2	FBA20/25-JZ
-	69135450	A30480-06010	Packing 56×45×7	2	FBA30-JZ
-	69135507	A35480-04011	Packing 63×53×6	2	FBA35-JZ
17	69135376	A20480-05007	Snap spring Φ50×Φ40×3	2	FBA20/25-JZ
-	69135449	A30480-06009	Snap spring Φ56×Φ45×3	2	FBA30-JZ
-		LS20041	Snap spring Φ63×Φ53×3	2	FBA35-JZ
18	69136174	Max202J01A-002	Bearing ring D50×8×2. 5	2	FBA20/25-JZ
-	69020038	Max302J01A-002	Bearing ring D56×8×2. 5	2	FBA30-JZ
-	69135505	A35480-04009	Bearing ring D63×20×2. 5	2	FBA35-JZ

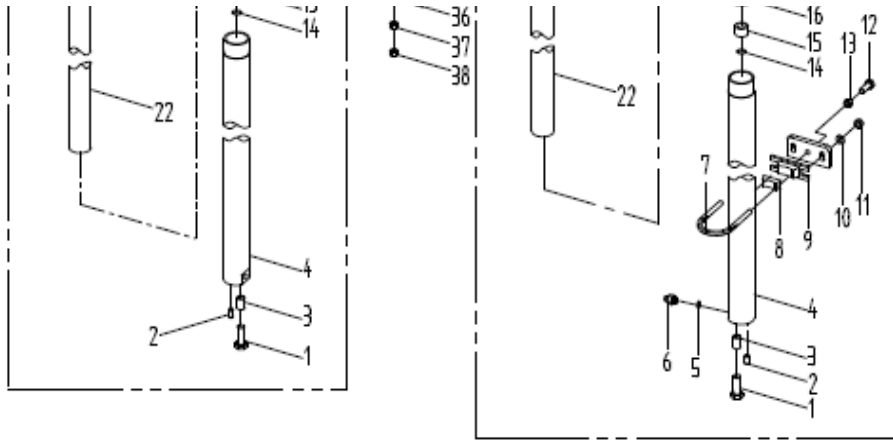

19	69135374	A20480-05005	Piston	2	FBA20/25-JZ
-	69135445	A30480-06005	Piston	2	FBA30-JZ
-	69135504	A35480-04008	Piston	2	FBA35-JZ
20	69135384	A20480-05200	Spool	2	
21	69136811	TLC-20T11	Sleeve $\Phi 40 \times 50$	按需	FBA20/25-JZ
-	69136812	TLC-30T18	Sleeve $\Phi 45 \times 50$	按需	FBA30-JZ
-	69135503	A35480-04007	Sleeve $\Phi 50 \times 50$	按需	FBA35-JZ
22	N/A	Max202J01-1	Piston Rod	2	FBA20/25-JZ
-	N/A	Max302J01-1	Piston Rod	2	FBA30-JZ
-	N/A	Max352J01-1	Piston Rod	2	FBA35-JZ

图57/FIG. 57

起升油缸(基本型)/LIFT CYLINDER(NORMAL MAST)

FBA20/25/30/35-JZ

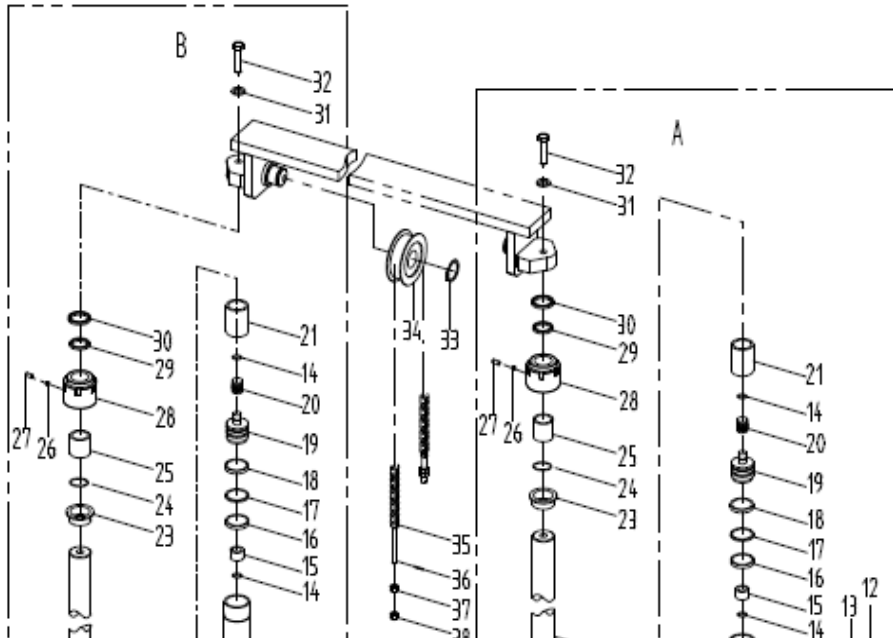

序号	物料号	代号	名称	数量	备注
Item No.	ID.	Part No.	Description	Q'ty	Remark
23	69135373	A20480-05004	Bushing	2	FBA20/25-JZ
-	69135444	A30480-06004	Bushing	2	FBA30-JZ
-	69135500	A35480-04004	Bushing	2	FBA35-JZ
24	69023164	GB/T1235-60*3.1	O-ring 60×3.1	2	FBA20/25-JZ
-	69009541	LS9541	O-ring 68×3.1	2	FBA30-JZ
-	69018828	GB/T1235-75*3.1	O-ring 75×3.1	2	FBA35-JZ
25	69135380	A20480-05011	Bushing Bearing 40×44×30	2	FBA20/25-JZ
-	69135453	A30480-06013	Bushing Bearing 45×50×30	2	FBA30-JZ
-	69021244	LS21244	Bushing Bearing 50×55×40	2	FBA35-JZ
26	69135454	A30480-06014	Nylon pad $\Phi 6 \times 3$	2	
27	69135188	GB/T 77-2000-M8*8	Bolt M8×8	2	FBA20/25/30-JZ
-	69094109	GB/T73-1985	Bolt M8×6	2	FBA35-JZ
28	69135372	A20480-05003	Cylinder cap	2	FBA20/25-JZ
-	69135443	A30480-06003	Cylinder cap	2	FBA30-JZ
-	69135481	A35480-04001	Cylinder cap	2	FBA35-JZ
29	69135378	A20480-05009	Packing 40×50×7	2	FBA20/25-JZ

















图58/FIG. 58

前起升油缸(二级全自由)/FRONT LIFT CYLINDER(FULL FREE 2-STAGE MAST)

FBA20/25/30/35-JZ

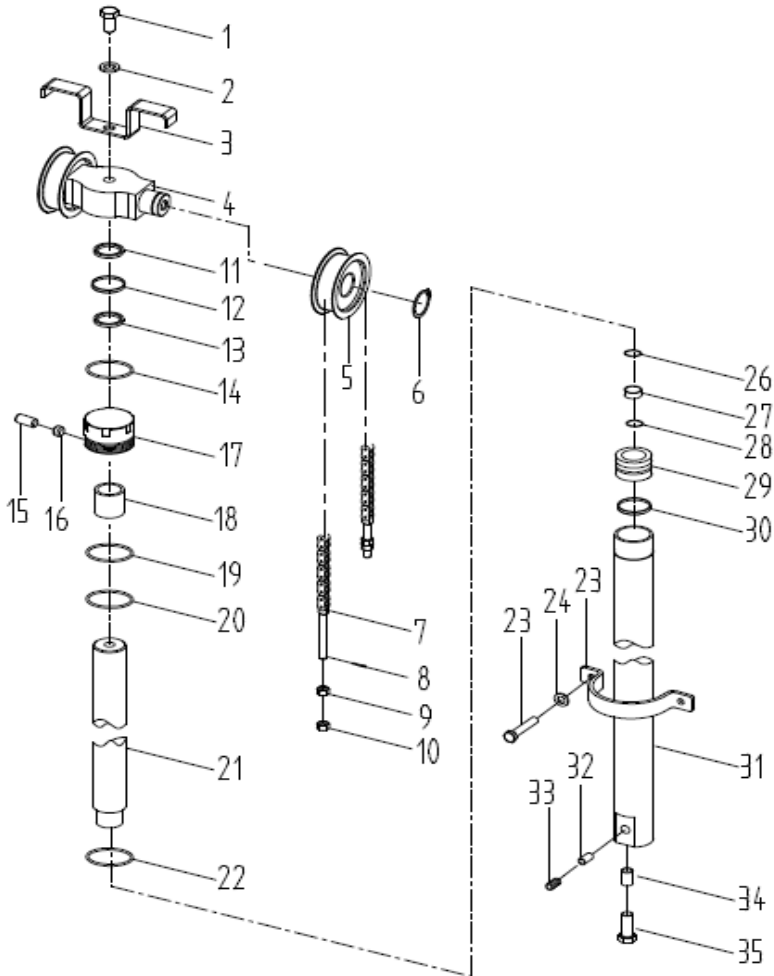

序号	物料号	代号	名称	数量	备注
Item No.	ID.	Part No.	Description	Q'ty	Remark
A	N/A	MJ20382-03000	Middle cylinder	1	FBA20/25-JZ
-	N/A	MJ30382-03000	Middle cylinder	1	FBA30-JZ
-	N/A	MJ35382-03000	Middle cylinder	1	FBA35-JZ
1	69000175	GB/T5782-M16*75-8.8J	Bolt M16×75	1	
2	69000056	GB/T93-16	Washer 16	1	
3	69106552	M30074000003-Black	Chain hoop	1	FBA20/25/30-JZ
-	69106434	M35043000003-Black	Chain hoop	1	FBA35-JZ
4	69087535	MJ30384-00002	Roller seat	1	FBA20/25/30-JZ
-	69106432	MJ35382-00001-Black	Roller seat	1	FBA35-JZ
5	69018464	M30074008000	Chain roller 780708H	2	FBA20/25/30-JZ
-	69007748	M3538006000	Chain roller A60309	2	FBA35-JZ
6	69000070	GB/T894.1-Φ40	Snap spring 40	2	
7	N/A	A25782-01000	Chain ass'y LH1234	2	FBA20/25-JZ
-	N/A	A30782-01000	Chain ass'y LH1623	2	FBA30-JZ
-	N/A	A35782-01000	Chain ass'y LH1634	2	FBA35-JZ
8	69017915	GB/T91-3.2*40	Cotter pin 3.2×40	4	
9	69107732	M3038001001	Nut M18×1.5	4	FBA20/25/30-JZ
-	69012580	M3538001001	Nut M22×1.5	4	FBA35-JZ
10	69000004	GB/T6171-M18*1.5-8J	Nut M18×1.5	4	FBA20/25/30-JZ
-	69136816	GB/T6171-2000-M22*1.5	Nut M22×1.5	4	FBA35-JZ
11	69135666	MJ20384-03010	Dustproof seal 60×74×8/11	1	FBA20/25-JZ
-	69135711	MJ30384-03010	Dustproof seal 70×84×8/11	1	FBA30-JZ
-	69135739	MJ35382-03009	Dustproof seal 75×89×8/11	1	FBA35-JZ
12	69135662	MJ20384-03006	Snap spring d70×φ60×3	1	FBA20/25-JZ



-	69135707	MJ30384-03006	Snap spring d80×φ70×3	1	FBA30-JZ
---	----------	---------------	-----------------------	---	----------

图58/FIG. 58 前起升油缸(二级全自由)/FRONT LIFT CYLINDER(FULL FREE 2-STAGE MAST)

FBA20/25/30/35-JZ

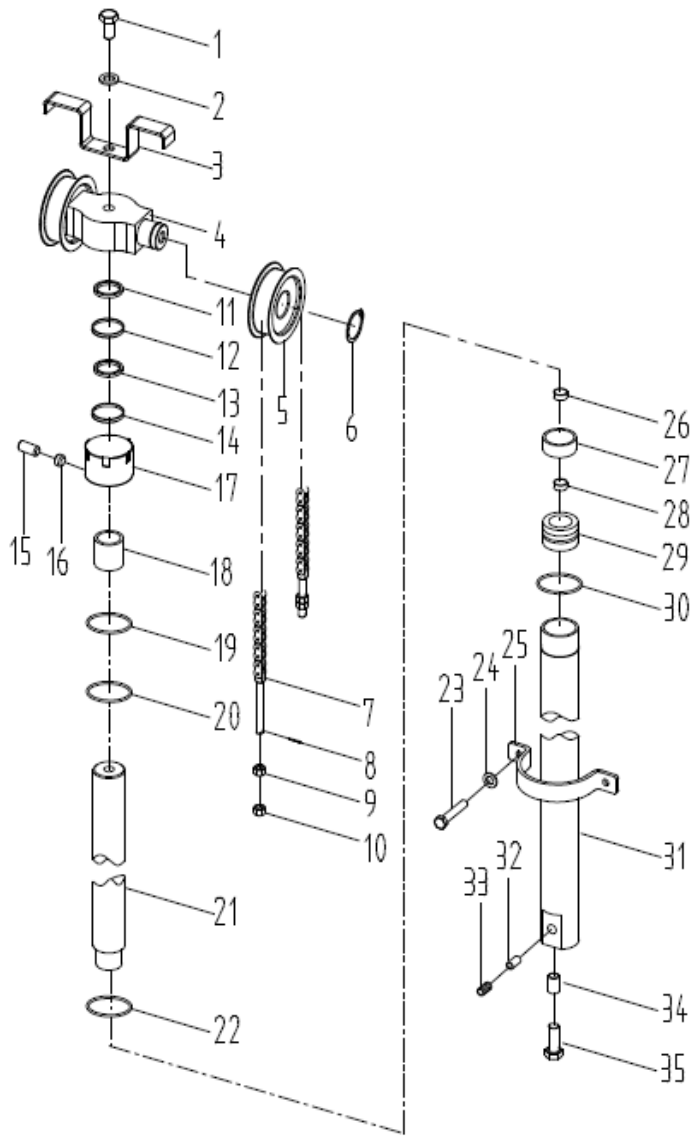

序号	物料号	代号	名称	数量	备注
Item No.	ID.	Part No.	Description	Q'ty	Remark
-	69135708	MJ30384-03007	Snap spring d85×φ75×3	1	FBA35-JZ
13	69135664	MJ20384-03008	Packing 60×70×6	1	FBA20/25-JZ
-	69135709	MJ30384-03008	Packing 70×80×6	1	FBA30-JZ
-	69135737	MJ35382-03007	Packing 75×85×6	1	FBA35-JZ
14	69135140	GB1235-80×3.1	O-ring 80×3.1	1	FBA20/25-JZ
-	69136506	GB1235-76-90×3.1	O-ring 90×3.1	1	FBA30-JZ
-	69136817	GB1235-76-100×3.1	O-ring 100×3.1	1	FBA35-JZ
15	69094106	GB/T80-M6×5	Plug M6×5	1	
16	69040793	JB982-6	Pad 6	1	
17	69135659	MJ20384-03003	Cylinder cap	1	FBA20/25-JZ
-	69135704	MJ30384-03003	Cylinder cap	1	FBA30-JZ
-	69135733	MJ35382-03003	Cylinder cap	1	FBA35-JZ
18	69135667	MJ20384-03011	Bushing Bearing 60×65×45	1	FBA20/25-JZ
-	69135712	MJ30384-03011	Bushing Bearing 70×75×45	1	FBA30-JZ
-	69131594	SF-1 75	Bushing Bearing 75×80×45	1	FBA35-JZ
19	69135663	MJ20384-03007	Snap spring d75×φ65×3	1	FBA20/25-JZ
-	69135708	MJ30384-03007	Snap spring d85×φ75×3	1	FBA30-JZ
-	69135736	MJ35382-03006	Snap spring d95×φ80×3	1	FBA35-JZ
20	69136718	GB1235-76-75×3.1	O-ring 75×3.1	1	FBA20/25-JZ
-	69023228	LS23228	O-ring 85×3.1	1	FBA30-JZ
-	69016275	GB/T1235-95×3.1	O-ring 95×3.1	1	FBA35-JZ
21	N/A	MJ202J05B-200	Piston Rod	1	FBA20/25-JZ
-	N/A	MJ302J05B-200	Piston Rod	1	FBA30-JZ
-	N/A	MJ352J05B-200	Piston Rod	1	FBA35-JZ
22	69136183	MAX202J05B-003	Bearing ring D75×20×2.5	2	FBA20/25-JZ

图58/FIG. 58

前起升油缸(二级全自由)/FRONT LIFT CYLINDER(FULL FREE 2-STAGE MAST)

FBA20/25/30/35-JZ

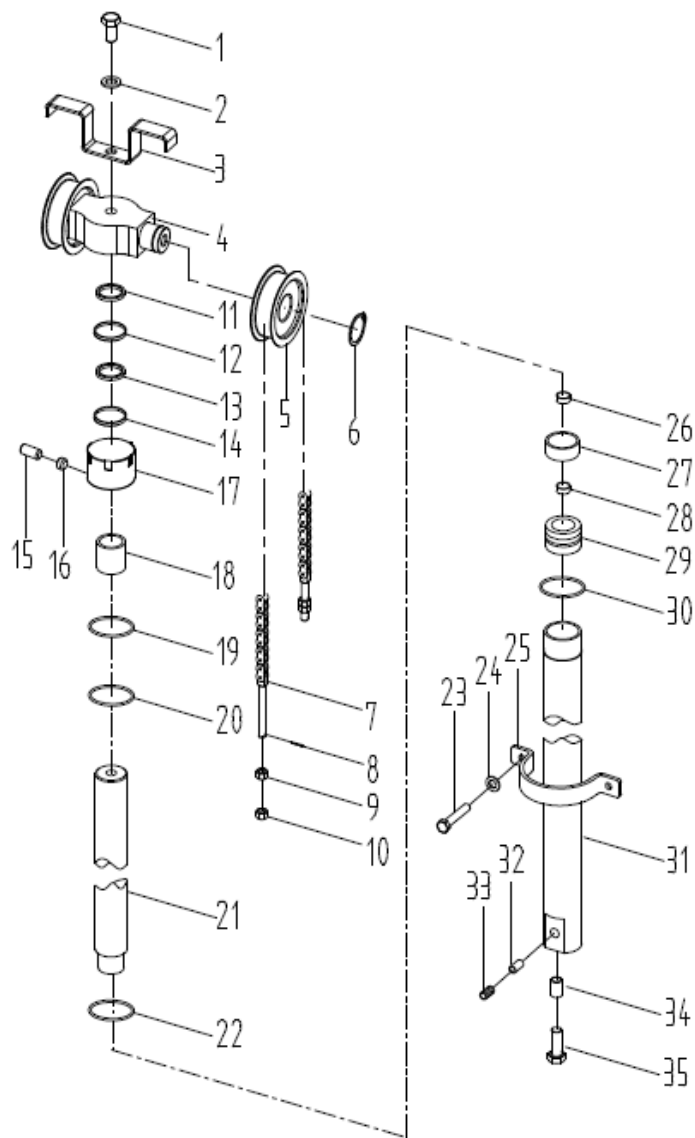

序号	物料号	代号	名称	数量	备注
Item No.	ID.	Part No.	Description	Q'ty	Remark
-	69135706	MJ30384-03005	Bearing ring D85×20×2.5	2	FBA30-JZ
-	69135735	MJ35382-03005	Bearing ring D95×20×2.5	2	FBA35-JZ
23	69032087	GB/T5786-M10*1.25*20-8.8J	Bolt M10×1.25×20	2	
24	69000053	GB/T93-10	Washer 10	2	
25	69112410	MJ20384-00001-Black	Hold hoop	1	FBA20/25-JZ
-	69106554	MJ30384-00001-Black	Hold hoop	1	FBA30-JZ
-	69106433	MJ35382-00002-Black	Hold hoop	1	FBA35-JZ
26	69135669	MJ20384-03013	Snap spring d40	1	
27	69136194	TLC015-SV100	One way valve	1	
28	69135668	MJ20384-03012	Orifice circlip d22	1	
29	69135660	MJ20384-03004	Piston		FBA20/25-JZ
-	69135705	MJ30384-03004	Piston		FBA30-JZ
-	69135734	MJ35382-03004	Piston		FBA35-JZ
30	69135665	MJ20384-03009	Packing 75×65×6	2	FBA20/25-JZ
-	69135710	MJ30384-03009	Packing 85×75×6	2	FBA30-JZ
-	69135738	MJ35382-03008	Packing 95×80×9	2	FBA35-JZ
31	N/A	MJ202J05B-100	Cylinder body	1	FBA20/25-JZ
-	N/A	MJ302J05B-100	Cylinder body	1	FBA30-JZ
-	N/A	MJ352J05B-100	Cylinder body	1	FBA35-JZ
32	69124144	GB/T3452.1-19*2.65-G	O-ring 19×2.65	1	
33	69136236	TLC-15T12	Safety valve	1	FBA20/25/30-JZ
-	N/A	CKM09-SH20-8	Safety valve	1	FBA35-JZ
34	69000137	GB/T5786-M12*1.25*25-8.8J	Bolt M12×1.25×25	2	
35	69000054	GB/T93-12	Washer 12	2	

图58/FIG. 58

前起升油缸(二级全自由)/FRONT LIFT CYLINDER(FULL FREE 2-STAGE MAST)

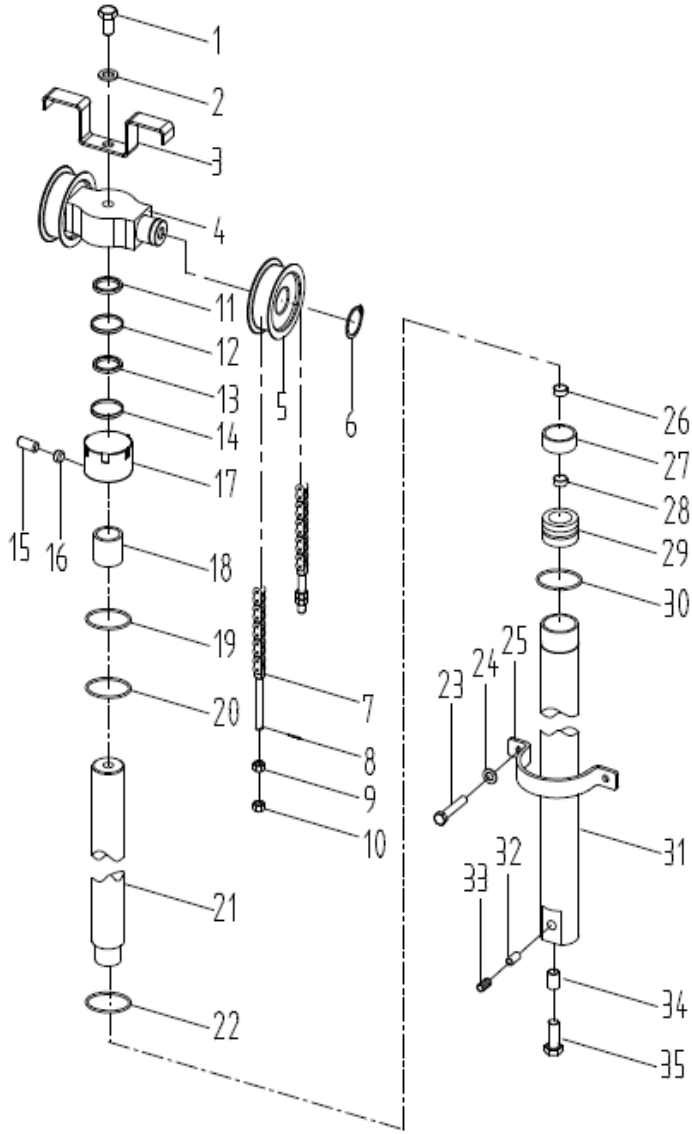

2-3.5前起升缸选用件(二级全自由)  
OPTIONAL PARTS 2-3.5 TON FRONT LIFT CYLINDER (FULL FREE 2-STAGE MAST)

起升高度 Lifting Height	物料号	2-2.5t前起升油缸 Lift cylinder	物料号	3t前起升油缸 Lift cylinder	备注 Remark
	ID.		ID.		
3000	69084011	MJ20382-03000-3.0M	69083920	382-03000	
3300	69084012	MJ20382-03000-3.3M	69083921	382-03000	
3500	69084013	MJ20382-03000-3.5M	69083922	382-03000	
3700	69084014	MJ20382-03000-3.7M	69083923	382-03000	
4000	69084015	MJ20382-03000-4.0M	69083924	382-03000	
4500	69084016	MJ20382-03000-4.5M	69083925	382-03000	
5000	69084017	MJ20382-03000-5.0M	69083926	382-03000	
5500	69084018	MJ20382-03000-5.5M	69083927	382-03000	
6000	69084019	MJ20382-03000-6.0M	69083928	382-03000	

图58/FIG. 58 前起升油缸(二级全自由)/FRONT LIFT CYLINDER (FULL FREE 2-STAGE MAST)

OPTIONAL PARTS 2-3.5 TON FRONT LIFT CYLINDER (FULL FREE 2-STAGE MAST)

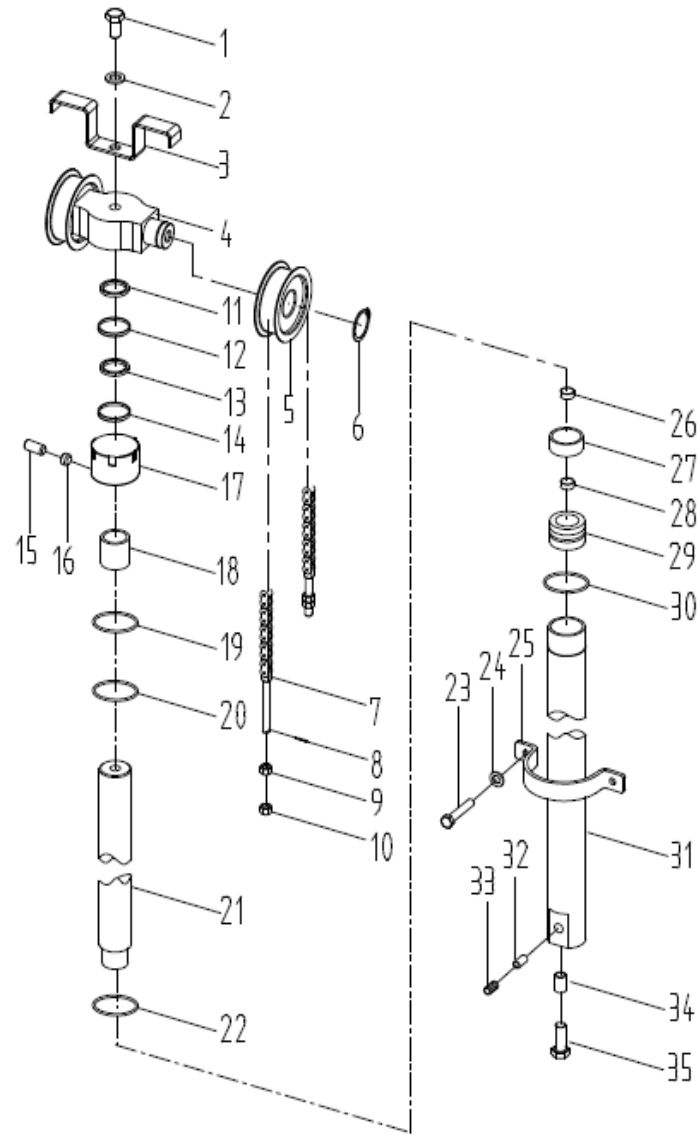

起升高度 Lift ing Height	物料号	3.5t前起升油缸 Lift cylinder			备注 Remark
	ID.				
3000	69083950	MJ35382-03000-3.0M			
3300	69083951	MJ35382-03000-3.3M			
3500	69083952	MJ35382-03000-3.5M			
3700	69083953	MJ35382-03000-3.7M			
4000	69083954	MJ35382-03000-4.0M			
4500	69083955	MJ35382-03000-4.5M			
5000	69083956	MJ35382-03000-5.0M			
5500	69083957	MJ35382-03000-5.5M			
6000	69083958	MJ35382-03000-6.0M			

图58/FIG. 58

前起升油缸(二级全自由)/FRONT LIFT CYLINDER(FULL FREE 2-STAGE MAST)

FBA20/25/30/35-JZ

2-3.5t链条总成选用件(二级全自由)  
OPTIONAL PARTS 2-3.5 TON Chain Ass'y (FULL FREE 2-STAGE MAST)

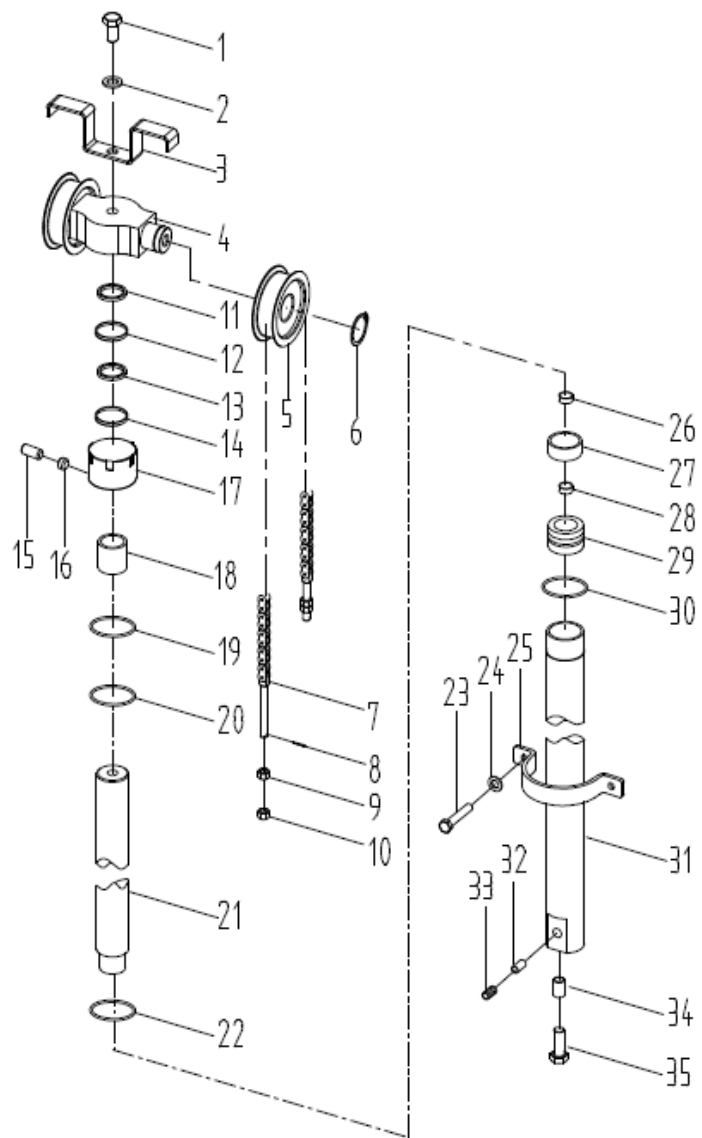

起升高度 Lifting Height	物料号	2-2.5t链条总成 Chain Ass'y	物料号	3t链条总成 Chain Ass'y	备注 Remark
	ID.		ID.		
3000	69116514	A25782-01000-3.0	69116755	82-01000	
3300	69116515	A25782-01000-3.3	69116756	82-01000	
3500	69116516	A25782-01000-3.5	69116757	82-01000	
3700	69116517	A25782-01000-3.7	69116758	82-01000	
4000	69116518	A25782-01000-4.0	69116759	82-01000	
4500	69116519	A25782-01000-4.5	69116760	82-01000	
5000	69116530	A25782-01000-5.0	69116761	82-01000	
5500	69116531	A25782-01000-5.5	69116762	82-01000	
6000	69116520	A25782-01000-6.0	69116763	82-01000	

图58/FIG. 58 前起升油缸(二级全自由)/FRONT LIFT CYLINDER(FULL FREE 2-STAGE MAST)

FBA20/25/30/35-JZ

2-3.5t链条总成选用件(二级全自由)  
OPTIONAL PARTS 2-3.5 TON Chain Ass'y (FULL FREE 2-STAGE MAST)

起升高度 Lift	物料号	3.5t链条总成		备注
--------------	-----	----------	--	----

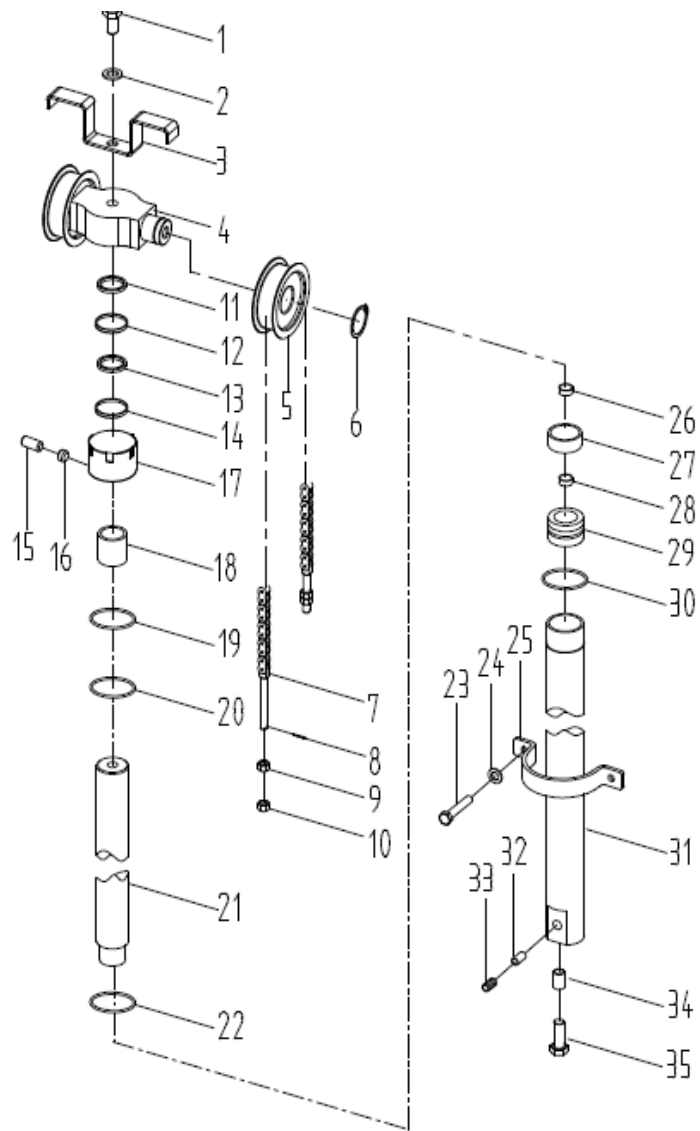

ing Height	ID.	Chain Ass'y			Remark
3000	69116652	A35782-01000-3.0			
3300	69116653	A35782-01000-3.3			
3500	69116654	A35782-01000-3.5			
3700	69116655	A35782-01000-3.7			
4000	69116656	A35782-01000-4.0			
4500	69116657	A35782-01000-4.5			
5000	69116658	A35782-01000-5.0			
5500	69116659	A35782-01000-5.5			
6000	69116660	A35782-01000-6.0			

图59/FIG. 59. 后起升油缸(二级全自由)/REAR LIFT CYLINDER(FULL FREE 2-STAGE MAST)

FBA20/25/30/35-JZ

序号	物料号	代号	名称	数量	备注
Item No.	ID.	Part No.	Description	Q'ty	Remark
A	N/A	M20043005000	Lift cylinder(right)	1	FBA20/25-JZ
-	N/A	M30043006000	Lift cylinder(right)	1	FBA30-JZ

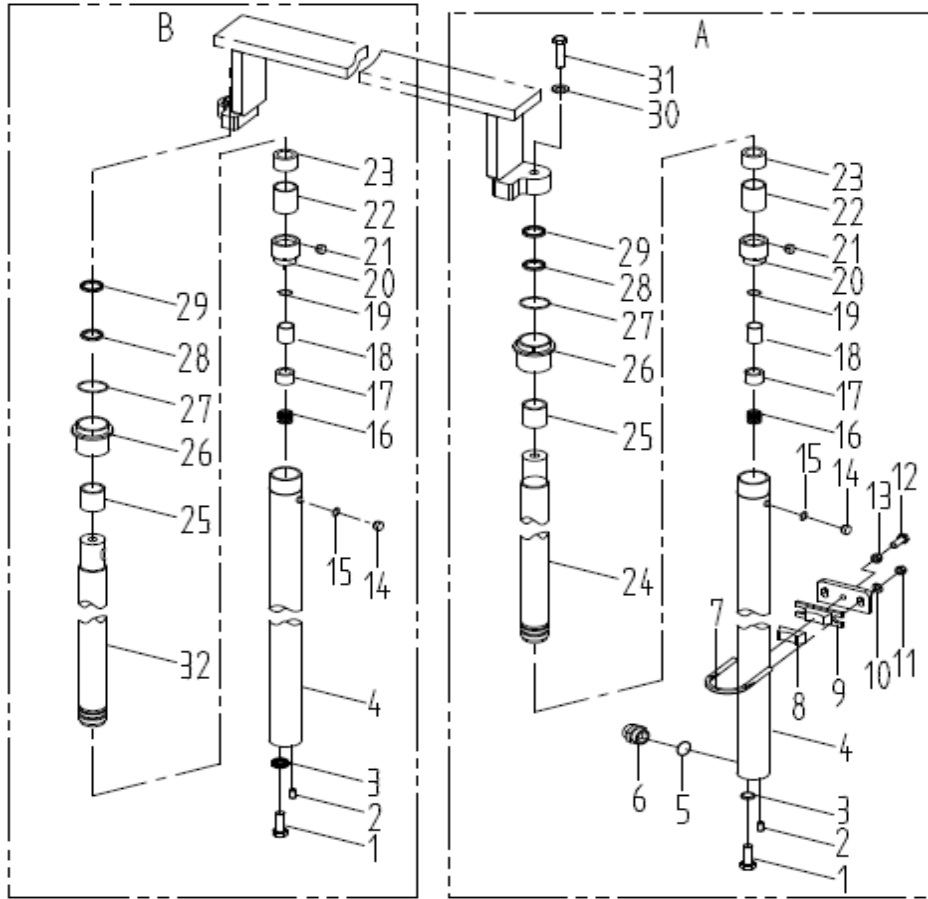

-	N/A	M35043005000	Lift cylinder(right)	1	FBA35-JZ
B	N/A	M20043006000	Lift cylinder(left)	1	FBA20/25-JZ
-	N/A	M30043005000	Lift cylinder(left)	1	FBA30-JZ
-	N/A	M35043006000	Lift cylinder(left)	1	FBA35-JZ
1	69000137	GB/T5786-M12*1.25*25-8.8J	Bolt M12×1.25×25	2	
2	69000337	GB/T119.2-Φ10*25	Cylindrical pin 10×25	2	
3	69000054	GB/T93-12	Washer 12	2	
4	N/A	Max202J03-100	Cylinder body	2	FBA20/25-JZ
-	N/A	Max302J03-100	Cylinder body	2	FBA30-JZ
-	N/A	Max352J04-100	Cylinder body	2	FBA35-JZ
5	69124131	GB1235-22*2.4-G	O-ring 22×2.4	1	
6	69135383	A20480-05100	Safety valve	1	FBA20/25-JZ
-	69135455	A30480-06100	Safety valve	1	FBA30/35-JZ
7	69006791	M3038000007	Hoop	2	
8	69012173	M3038000008	Rubber	2	
9	69012171	M3038009000	Packing	2	
10	69000250	GB/T97.1-10	Washer 10	4	
11	69000313	GB/T6171-M10*1.25-8J	Nut M10×1.25	4	
12	69000140	GB/T5786-M12*1.25*45-8.8J	Bolt M12×1.25×45	2	
13	69000314	GB/T6171-M12*1.25-8J	Nut M12×1.25	2	
14	69135575	M30043005010	Deflate plug M8	2	
15	69094104	JB982-77	Seal ring 8	2	
16	69135577	M30043005012	Spring	2	FBA20/25/30-JZ

图59/FIG. 59.

后起升油缸(二级全自由)/REAR LIFT CYLINDER(FULL FREE 2-STAGE MAST)

FBA20/25/30/35-JZ

序号	物料号	代号	名称	数量	备注
Item No.	ID.	Part No.	Description	Q' ty	Remark
-	69135615	M35043005013	Spring	2	FBA35-JZ
17	69135572	M30043005007	Sleeve	2	FBA20/25/30-JZ
-	69135610	M35043005008	Sleeve	2	FBA35-JZ

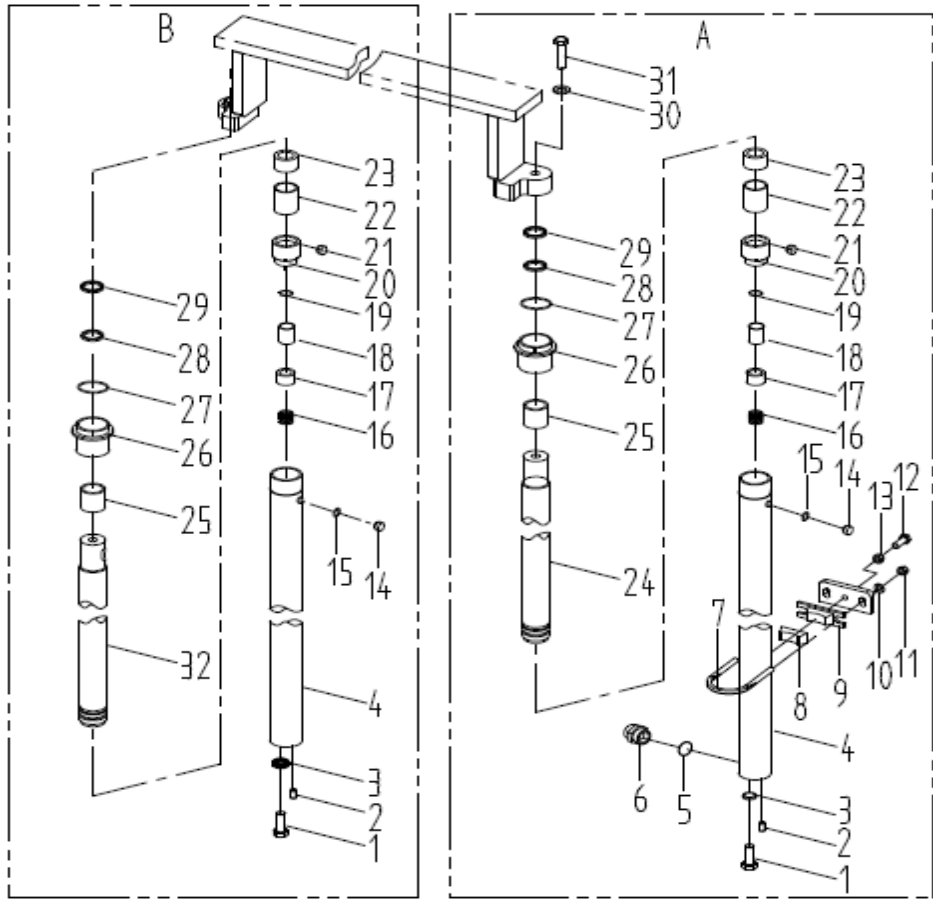

18	69135571	M30043005006	Stopper	2	FBA20/25/30-JZ
-	69135609	M35043005007	Stopper	2	FBA35-JZ
19	69136818	GB895. 2-86	Snap ring 18	2	FBA20/25/30-JZ
-	69136819	GB895. 2-86-20	Snap ring 20	2	FBA35-JZ
20	69135548	M20043005004	Piston	2	FBA20/25-JZ
-	69135570	M30043005005	Piston	2	FBA30-JZ
-	69135608	M35043005006	Piston	2	FBA35-JZ
21	69017708	GB/T819. 1-M5*6	Bolt M5×6	2	
22	69135549	M20043005005	Bearing ring D45×20×2.5	2	FBA20/25-JZ
-	69135573	M30043005008	Bearing ring D50×20×2.5	2	FBA30-JZ
-	69135611	M35043005009	Bearing ring D56×20×2.5	2	FBA35-JZ
23	69136820	TLC-15T18	Sleeve Φ35×100	2	FBA20/25-JZ
-	69136821	TLC-20T12	Sleeve Φ40×100	2	FBA30-JZ
-	69135607	M35043005005	Sleeve Φ45×100	2	FBA35-JZ
24	N/A	Max202J04-1	Piston Rod (right)	1	FBA20/25-JZ
-	N/A	Max302J04-1	Piston Rod (right)	1	FBA30-JZ
-	N/A	Max352J04-1	Piston Rod (right)	1	FBA35-JZ
25	69135423	A30480-05014	Bushing Bearing 35×39×30	2	FBA20/25-JZ
-	69135380	A20480-05011	Bushing Bearing 40×44×30	2	FBA30-JZ
-	69135453	A30480-06013	Bushing Bearing 45×50×30	2	FBA35-JZ
26	69135547	M20043005003	Cylinder cap	2	FBA20/25-JZ
-	69135569	M30043005003	Cylinder cap	2	FBA30-JZ

图59/FIG. 59.

后起升油缸(二级全自由)/REAR LIFT CYLINDER(FULL FREE 2-STAGE MAST)

FBA20/25/30/35-JZ

序号	物料号	代号	名称	数量	备注
Item No.	ID.	Part No.	Description	Q'ty	Remark
-	69135605	M35043005003	Cylinder cap	2	FBA35-JZ
27	69136822	GB/T3452. 1-2005-45×2. 65	O-ring 45×2. 65	2	FBA20/25-JZ
-	69136823	GB/T3452. 1-2005-50×2. 65	O-ring 50×2. 65	2	FBA30-JZ
-	69136824	GB/T3452. 1-2005-56×2. 65	O-ring 56×2. 65	2	FBA35-JZ



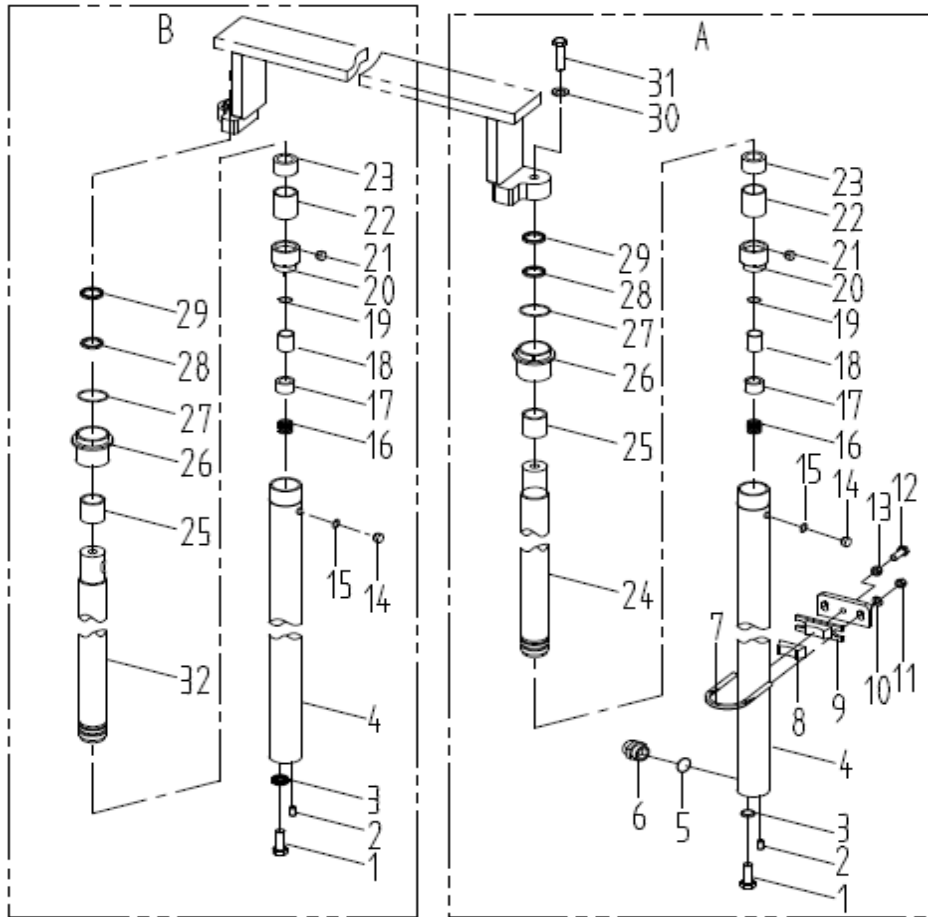

28	69135419	A30480-05010	Packing 35×45×6	2	FBA20/25-JZ
-	69135574	M30043005009	Packing 40×50×6	2	FBA30-JZ
-	69135613	M35043005011	Packing 45×50×6	2	FBA35-JZ
29	69135550	M20043005006	Dust-proof seal 35×47×7/10	2	FBA20/25-JZ
-	69135379	A20480-05010	Dust-proof seal 40×52×7/10	2	FBA30-JZ
-	69135452	A30480-06012	Dust-proof seal 45×57×7/10	2	FBA35-JZ
30	69000056	GB/T93-16	Washer 16	2	
31	69006551	GB/T5783-M16*40-8.8J	Bolt M16×40	2	
32	N/A	Max202J03-1	Piston Rod (left)	1	FBA20/25-JZ
-	N/A	Max302J03-1	Piston Rod (left)	1	FBA30-JZ
-	N/A	Max352J03-2	Piston Rod (left)	1	FBA35-JZ

图59/FIG. 59.

后起升油缸(二级全自由)/REAR LIFT CYLINDER(FULL FREE 2-STAGE MAST)

FBA20/25/30/35-JZ

2-3.5t起升油缸选用表(二级全自由)  
LIFT CYLINDER OPTION TABLE(FULL FREE 2-STAGE MAST ZM)

起升高度 Lifting Height	物料号	2-2.5t左起升油缸 Lift cylinder L.H.	物料号
	ID.		ID.
3000	69003314	M20043006000-3.0M	69102420
3300	69005079	M20043006000-3.3M	69102424
3500	69006780	M20043006000-3.5M	69102433

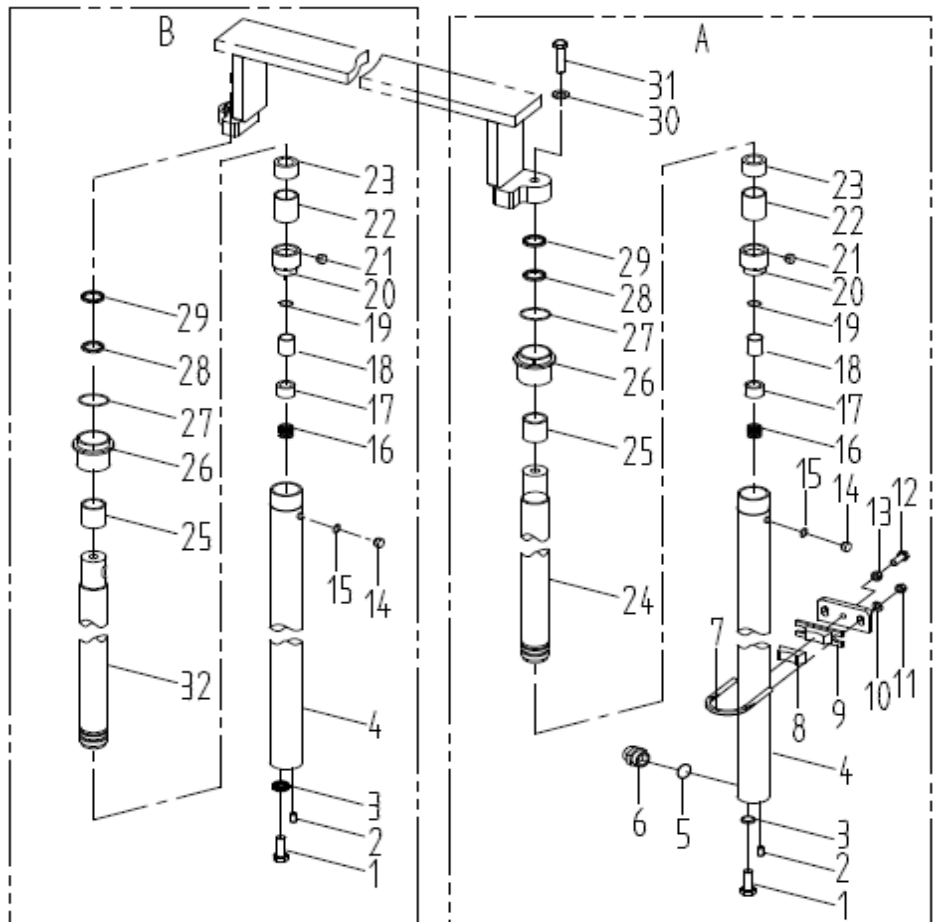

3700	69009024	M20043006000-3.7M	69102451	
4000	69049067	M20043006000-4.0M	69103583	
4500	69049068	M20043006000-4.5M	69103584	
5000	69049070	M20043006000-5.0M	69103585	
5500	69049071	M20043006000-5.5M	69103586	
6000	69049072	M20043006000-6.0M	69103587	

图59/FIG. 59. 后起升油缸(二级全自由)/REAR LIFT CYLINDER(FULL FREE 2-STAGE MAST)

FBA20/25/30/35-JZ

2-3.5t起升油缸选用表(二级全自由)  
LIFT CYLINDER OPTION TABLE(FULL FREE 2-STAGE MAST ZM)

起升高度 Lifting Height	物料号	3t左起升油缸 Lift cylinder L.H.	物料号
	ID.		ID.
3000	69102415	M30043005000-3.0M	69002818
3300	69102454	M30043005000-3.3M	69009210
3500	69102954	M30043005000-3.5M	69016085
3700	69103576	M30043005000-3.7M	69049035

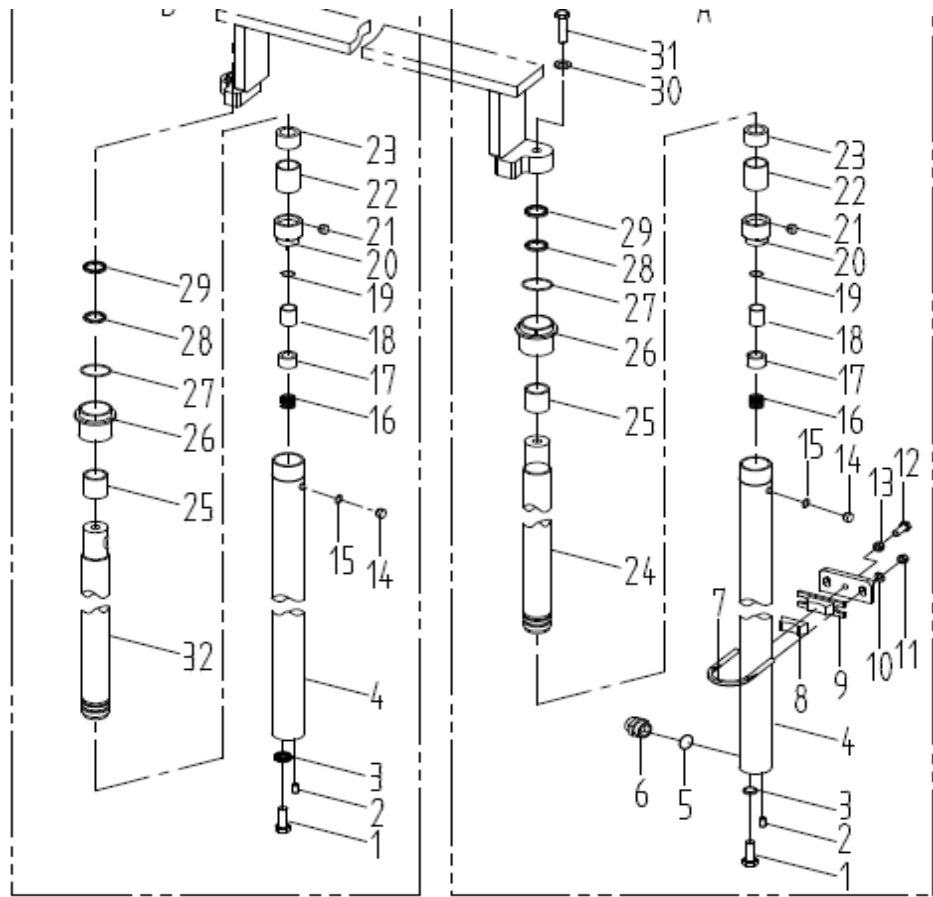

4000	69103565	M30043005000-4.0M	69017621	
4500	69103578	M30043005000-4.5M	69049038	
5000	69103579	M30043005000-5.0M	69049039	
5500	69103577	M30043005000-5.5M	69049037	
6000	69103580	M30043005000-6.0M	69049040	

图59/FIG. 59. 后起升油缸(二级全自由)/REAR LIFT CYLINDER(FULL FREE 2-STAGE MAST)

FBA20/25/30/35-JZ

2-3.5t起升油缸选用表(二级全自由)  
LIFT CYLINDER OPTION TABLE(FULL FREE 2-STAGE MAST ZM)

起升高度 Lifting Height	物料号	3.5t左起升油缸 Lift cylinder L.H.	物料号	3.5t右起升油缸 Lift	备注 Remark
	ID.		ID.		
3000	69102414	M35043006000-3.0M	69009080	M35043005000-	
3300	69102755	M35043006000-3.3M	69010680	M35043005000-	
3500	69103568	M35043006000-3.5M	69024648	M35043005000-	
3700	69104174	M35043006000-3.7M	69050433	M35043005000-	
4000	69105388	M35043006000-4.0M	69105389	M35043005000-	

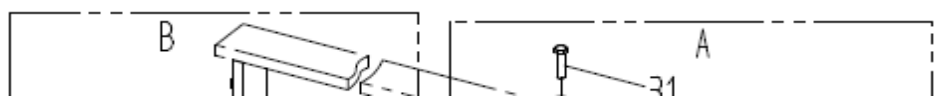

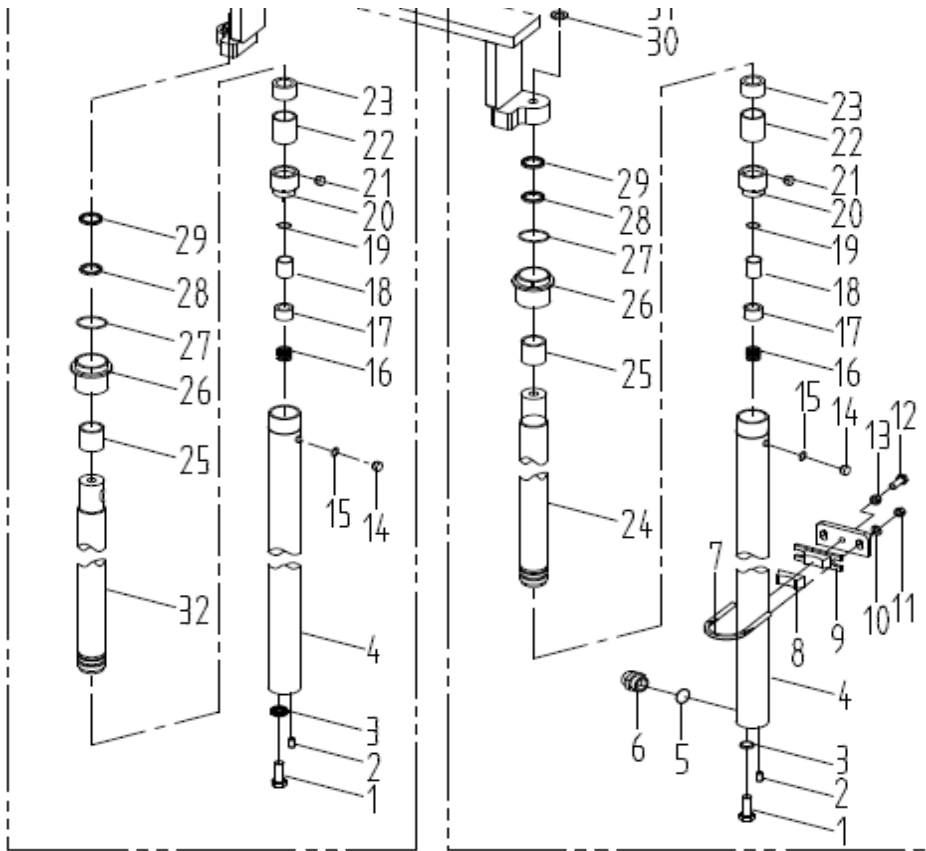

4500	69050436	M35043006000-4.5M	69103599	M35043005000-	
5000	69103602	M35043006000-5.0M	69050459	M35043005000-	
5500	69103601	M35043006000-5.5M	69050451	M35043005000-	
6000	69103603	M35043006000-6.0M	69050470	M35043005000-	

图60/Fig. 60

前起升油缸(三级全自由)/FRONT LIFT CYLINDER(FULL FREE 3-STAGE MAST)

FBA20/25/30/35-JZ

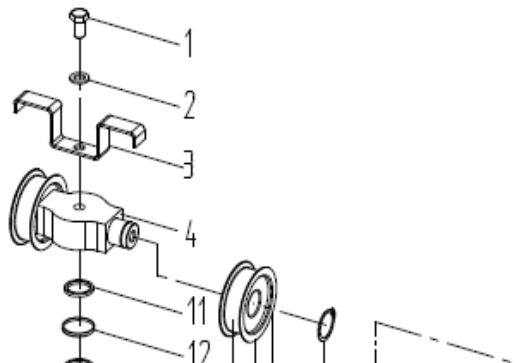

序号 Item No.	物料号 ID.	代号 Part No.	名称 Description	数量 Q'ty	备注 Remark
A	N/A	MJ20384-03000	Middle cylinder	1	FBA20/25-JZ
-	N/A	MJ30384-03000	Middle cylinder	1	FBA30/35-JZ
1	69000175	GB/T5782-M16*75-8.8J	Bolt M16×75	1	
2	69000056	GB/T93-16	Washer 16	1	
3	69106552	M30074000003-Black	Chain hoop	1	
4	69087535	MJ30384-00002	Roller seat	1	FBA20/25/30-JZ
-	69086847	MJ35384-00001	Roller seat	1	FBA35-JZ
5	69018464	M30074008000	Chain roller 780708H	2	FBA20/25/30-JZ

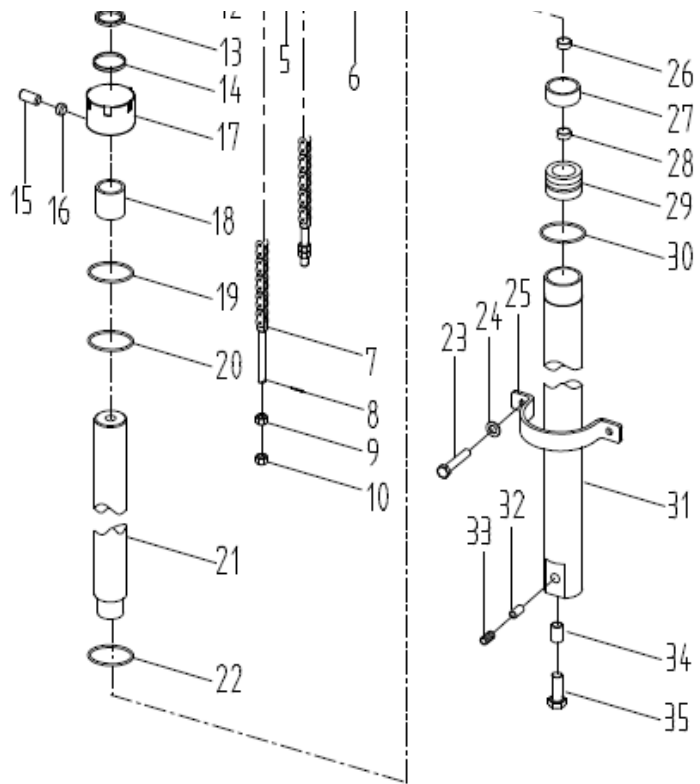

-	69007748	M3538006000	Chain roller A60309	2	FBA35-JZ
6	69000070	GB/T894.1-Φ40	Snap spring 40	2	
7	N/A	A25784-06000	Chain ass'y LH1234	2	FBA20/25-JZ
-	N/A	A30784-06000	Chain ass'y LH1623	2	FBA30-JZ
-	N/A	A35784-06000	Chain ass'y LH1634	2	FBA35-JZ
8	69017915	GB/T91-3.2*40	Cotter pin 3.2×40	4	
9	69107732	M3038001001	Nut M18×1.5	4	FBA20/25/30-JZ
-	69012580	M3538001001	Nut M22×1.5	4	FBA35-JZ
10	69000004	GB/T6171-M18*1.5-8J	Nut M18×1.5	4	FBA20/25/30-JZ
-	69136816	GB/T6171-2000-M22*1.5	Nut M22×1.5	4	FBA35-JZ
11	69135666	MJ20384-03010	Dustproof seal 60×70×8/11	1	FBA20/25-JZ
-	69135711	MJ30384-03010	Dustproof seal 70×84×8/11	1	FBA30/35-JZ
12	69135662	MJ20384-03006	Snap spring d70×Φ60×3	1	FBA20/25-JZ
-	69135707	MJ30384-03006	Snap spring d80×Φ70×3	1	FBA30/35-JZ
13	69135664	MJ20384-03008	Axis seal 60×70×6	1	FBA20/25-JZ
-	69135709	MJ30384-03008	Axis seal 70×80×6	1	FBA30/35-JZ
14	69136718	GB1235-76-75×*3.1	O-ring 75×3.1	1	FBA20/25-JZ

图60/Fig. 60

前起升油缸(三级全自由)/FRONT LIFT CYLINDER(FULL FREE 3-STAGE MAST)

FBA20/25/30/35-JZ

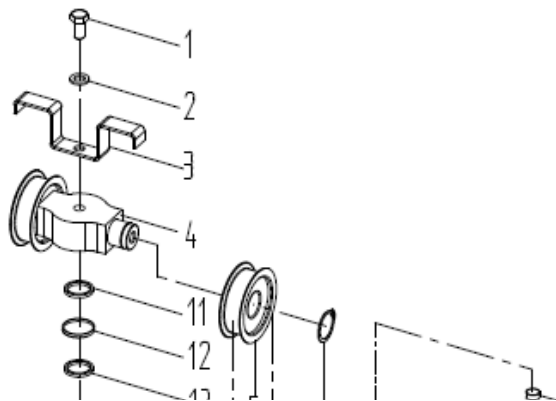

序号	物料号	代号	名称	数量	备注
Item No.	ID.	Part No.	Description	Q'ty	Remark
-	69023228	LS23228	O-ring 85×3.1	1	FBA30/35-JZ
15	69094106	GB/T80-M6*5	Bolt M6×5	1	内六角
16	69040793	JB982-6	Pad 6	1	
17	69040190	TLC-20T08	Cylinder cap	1	FBA20/25-JZ
-	N/A	TLC-30T11	Cylinder cap	1	FBA30/35-JZ
18	69135667	MJ20384-03011	Bushing Bearing 60×65×45	1	FBA20/25-JZ
-	69135712	MJ30384-03011	Bushing Bearing 70×75×45	1	FBA30/35-JZ
19	69135663	MJ20384-03007	Snap spring d75×Φ65×3	1	FBA20/25-JZ
-	69135708	MJ30384-03007	Snap spring d85×Φ75×3	1	FBA30/35-JZ

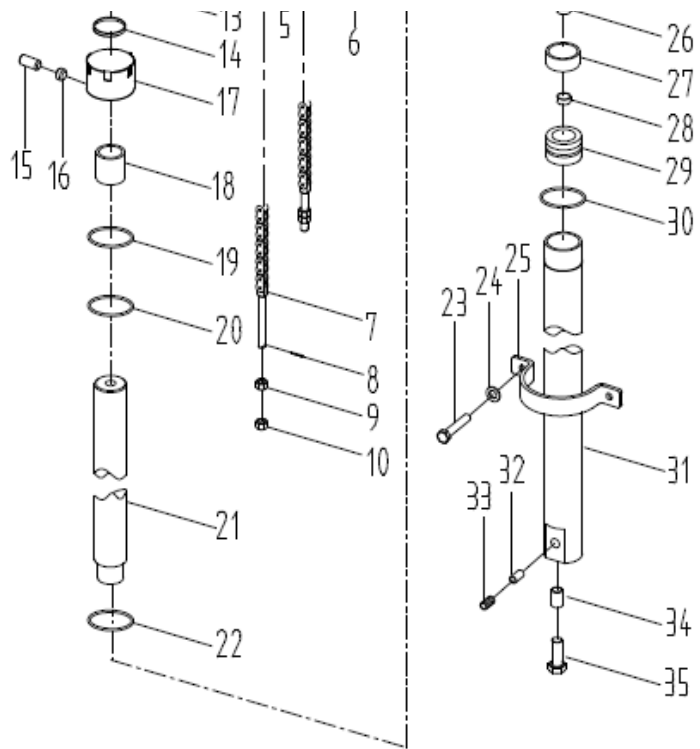

20	69136718	GB1235-76-75×*3.1	O-ring 75×3.1	1	FBA20/25-JZ
-	69023228	LS23228	O-ring 85×3.1	1	FBA30/35-JZ
21	N/A	MJ203J03B-200	Piston Rod	1	FBA20/25-JZ
-	N/A	MJ303J03B-200	Piston Rod	1	FBA30/35-JZ
22	69135661	MJ20384-03005	Bearing ring D70×20×2.5	1	FBA20/25-JZ
-	69135706	MJ30384-03005	Bearing ring D85×20×2.5	1	FBA30/35-JZ
23	69032087	GB/T5786-M10*1.25*20-8.8J	Bolt M10×1.25×20	2	
24	69000053	GB/T93-10	Washer 10	2	
25	69112410	MJ20384-00001-Black	Hold hoop	1	FBA20/25-JZ
-	69106554	MJ30384-00001-Black	Hold hoop	1	FBA30-JZ
-	69106433	MJ35382-00002-Black	Hold hoop	1	FBA35-JZ
26	69135669	MJ20384-03013	Snap spring d40	1	
27	69135384	A20480-05200	One way valve	1	
28	69084487	GB/T893.1-Φ22	Orifice circlip d22	1	
29	69135660	MJ20384-03004	Piston	1	FBA20/25-JZ
-	69135705	MJ30384-03004	Piston	1	FBA30/35-JZ

图60/Fig. 60

前起升油缸(三级全自由)/FRONT LIFT CYLINDER(FULL FREE 3-STAGE MAST)

FBA20/25/30/35-JZ

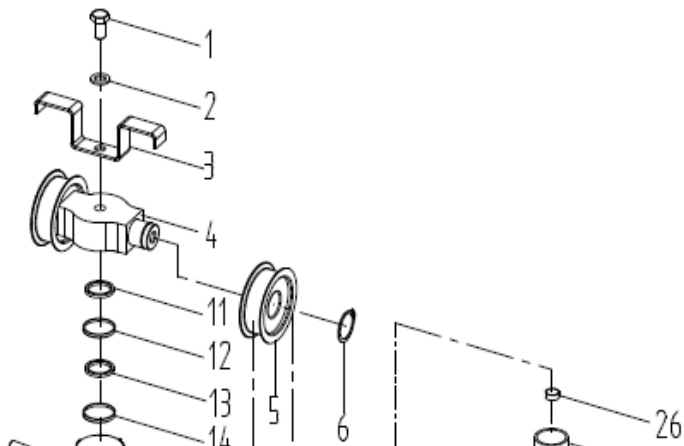

序号	物料号	代号	名称	数量	备注
Item No.	ID.	Part No.	Description	Q'ty	Remark
30	69135665	MJ20384-03009	Packing 75×65×6	2	FBA20/25-JZ
-	69135710	MJ30384-03009	Packing 85×75×6	2	FBA30/35-JZ
31	N/A	MJ203J03B-100	Cylinder body	1	FBA20/25-JZ
-	N/A	MJ303J03B-100	Cylinder body	1	FBA30/35-JZ
32	69124144	GB/T3452.1-19*2.65-G	O-ring 19×2.65	1	
33	69072586	TLC-20T14	Safety valve	1	FBA20/25-JZ
-	69072587	TLC-30T27	Safety valve	1	FBA30/35-JZ
34	69000137	GB/T5786-M12*1.25*25-8.8J	Bolt M12×1.25×25	1	
35	69000054	GB/T93-12	Washer 12	1	





图60/Fig. 60

前起升油缸(三级全自由)/FRONT LIFT CYLINDER(FULL FREE 3-STAGE MAST)

FBA20/25/30/35-JZ

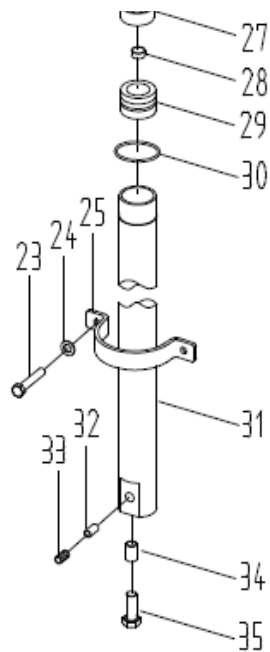
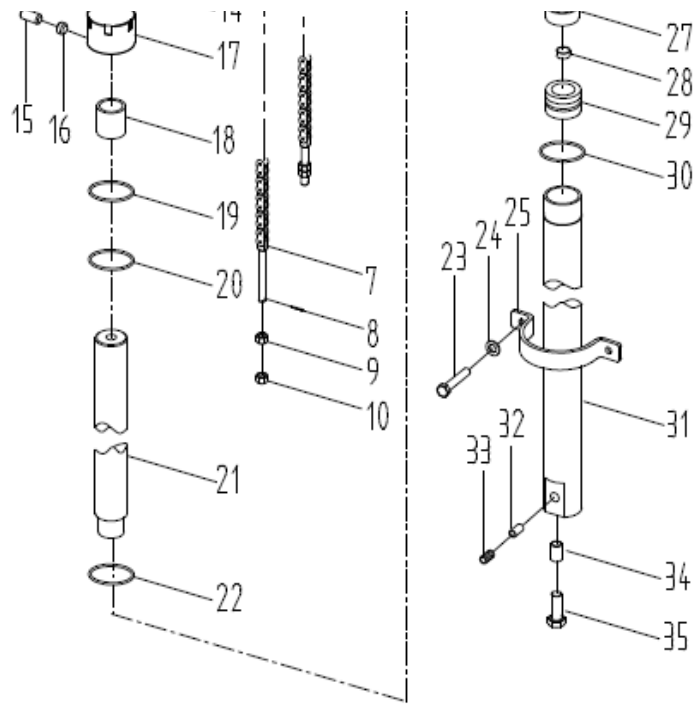
2-3.5t前起升油缸选用表  
FRONT LIFT CYLINDER OPTION TABLE

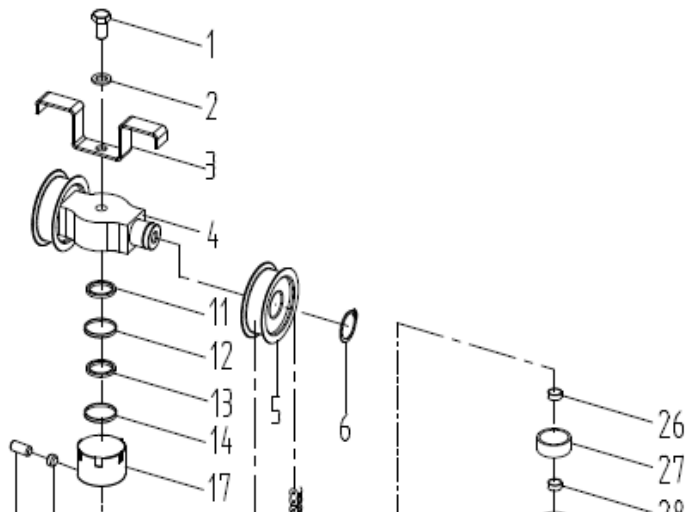
起升高度Lift ing Height	物料号	2-2.5t前起升油缸 Lift cylinder	物料号	3-3.5t前起升油缸	备注 Remark
	ID.		ID.		
3600	69084042	MJ20384-03000-3.6M	69083119	MJ30384-03000-	
4000	69084044	MJ20384-03000-4.0M	69083118	MJ30384-03000-	
4350	69084045	MJ20384-03000-4.35M	69083120	MJ30384-03000-	
4500	69084046	MJ20384-03000-4.5M	69083121	MJ30384-03000-	
4800	69084047	MJ20384-03000-4.8M	69083122	MJ30384-03000-	
5000	69084048	MJ20384-03000-5.0M	69083123	MJ30384-03000-	
5500	69084050	MJ20384-03000-5.5M	69083125	MJ30384-03000-	
6000	69084051	MJ20384-03000-6.0M	69083126	MJ30384-03000-	







图60/Fig. 60

前起升油缸(三级全自由)/FRONT LIFT CYLINDER(FULL FREE 3-STAGE MAST)

FBA20/25/30/35-JZ

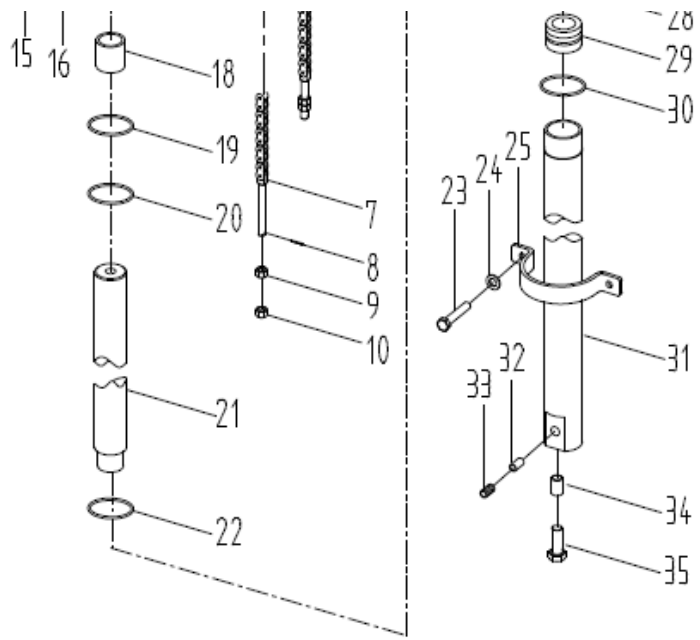
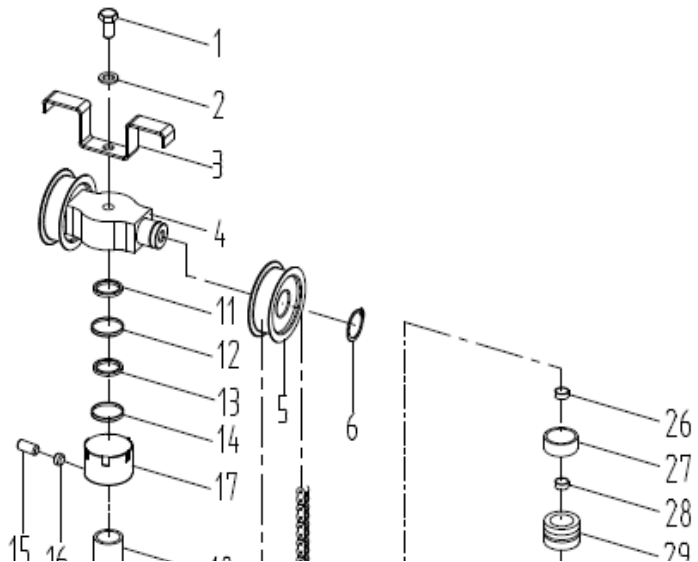

2-3.5t链条总成选用表  
Chain Ass'y OPTION TABLE

起升高度 Lifting Height	物料号	2-2.5t链条总成 Chain Ass'y	物料号	3t链条 总成 Chain Ass'y	备注 Remark
	ID.		ID.		
3600	69116633	A25784-06000-3.6	69116819	84-06000	
4000	69116634	A25784-06000-4.0	69116820	84-06000	
4350	69116635	A25784-06000-4.35	69116821	84-06000	
4500	69116636	A25784-06000-4.5	69116822	84-06000	
4800	69116637	A25784-06000-4.8	69116823	84-06000	
5000	69116638	A25784-06000-5.0	69116824	84-06000	
5500	69116639	A25784-06000-5.5	69116826	84-06000	
6000	69116640	A25784-06000-6.0	69116827	84-06000	





图60/Fig. 60

前起升油缸(三级全自由)/FRONT LIFT CYLINDER(FULL FREE 3-STAGE MAST)

FBA20/25/30/35-JZ

2-3.5t链条总成选用表  
Chain Ass'y OPTION TABLE

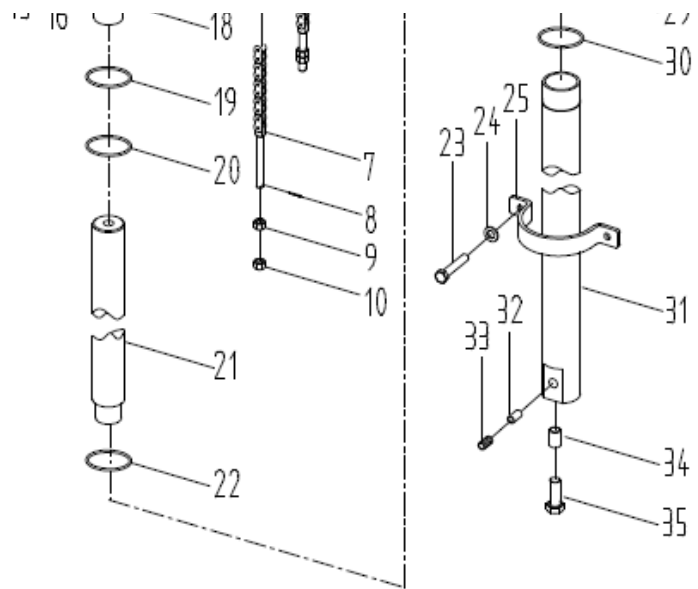
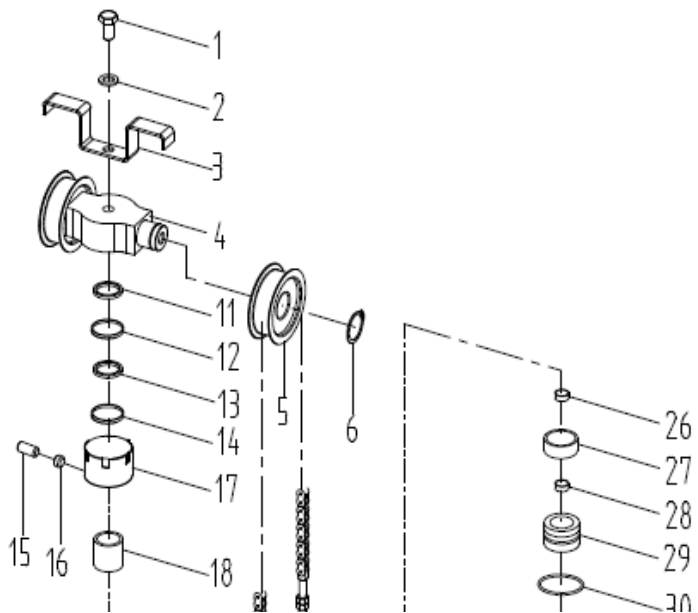
起升高度Lifting Height	物料号	3.5t链条总成 Chain Ass'y		3.5t链条总成 Chain Ass'y	备注 Remark
	ID.				
3600	69116719	A35784-06000-3.6			
4000	69116721	A35784-06000-4.0			
4350	69116722	A35784-06000-4.35			
4500	69116724	A35784-06000-4.5			
4800	69116725	A35784-06000-4.8			
5000	69116726	A35784-06000-5.0			
5500	69116729	A35784-06000-5.5			
6000	69116731	A35784-06000-6.0			





图61/Fig. 61 后起升油缸(三级全自由)/REAR LIFT CYLINDER(FULL FREE 3-STAGE MAST)

FBA20/25/30/35-JZ

序号 Item No.	物料号 ID.	代号 Part No.	名称 Description	数量 Q'ty	备注 Remark
A	N/A	A20484-02000	Lift cylinder(right)	1	FBA20/25-JZ
-	N/A	A30484-05000	Lift cylinder(right)	1	FBA30-JZ
-	N/A	A35484-05000	Lift cylinder(right)	1	FBA35-JZ
B	N/A	A20484-07000	Lift cylinder(left)	1	FBA20/25-JZ
-	N/A	A30484-06000	Lift cylinder(left)	1	FBA30-JZ
-	N/A	A35484-06000	Lift cylinder(left)	1	FBA35-JZ
1	69000137	GB/T5786-M12*1.25*25-8.8J	Bolt M12×1.25×25	2	
2	69000337	GB/T119. 2-Φ10*25	Pin 10×25	1	
3	69000054	GB/T93-12	Washer 12	2	
4	N/A	Max203J02A-100	Cylinder body(right)	1	FBA20/25-JZ
-	N/A	Max303J02A-100	Cylinder body(right)	1	FBA30/35-JZ
5	69124131	GB1235-22*2.4-G	O-ring 22×2.4	1	
6	69135383	A20480-05100	Safety valve	1	FBA20/25-JZ
-	69135455	A30480-06100	Safety valve	1	FBA30/35-JZ

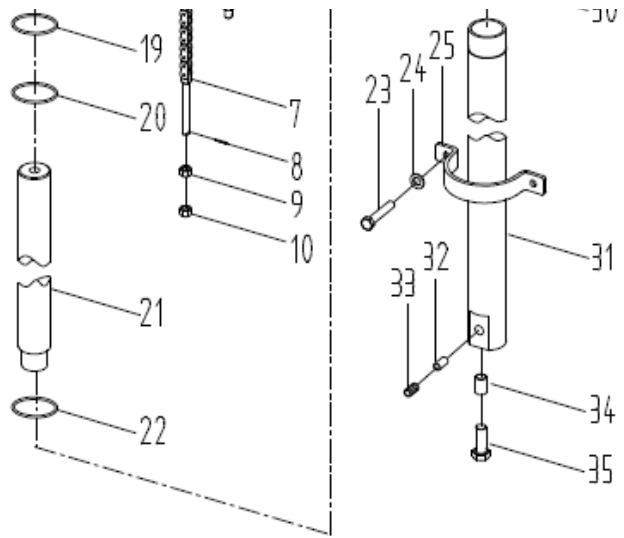
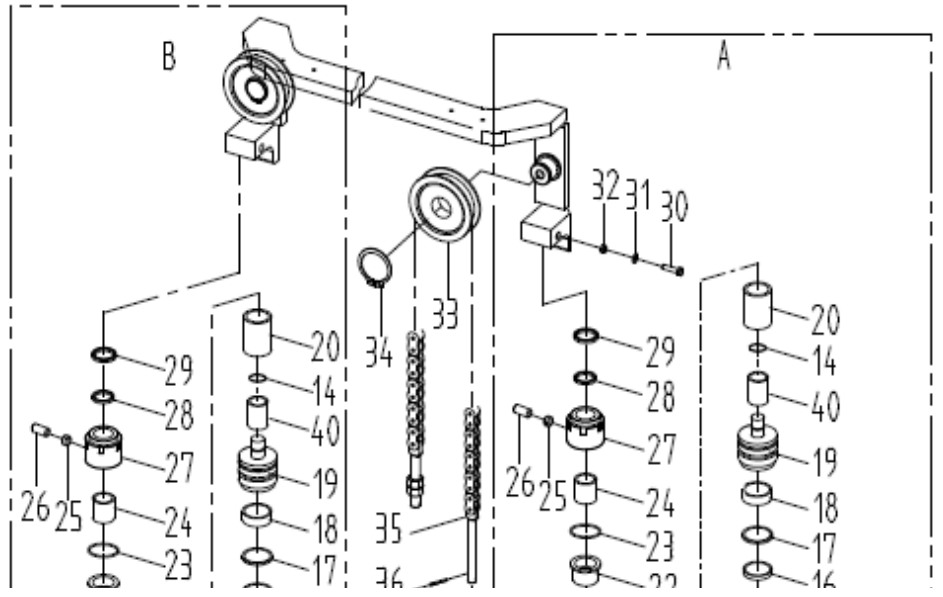
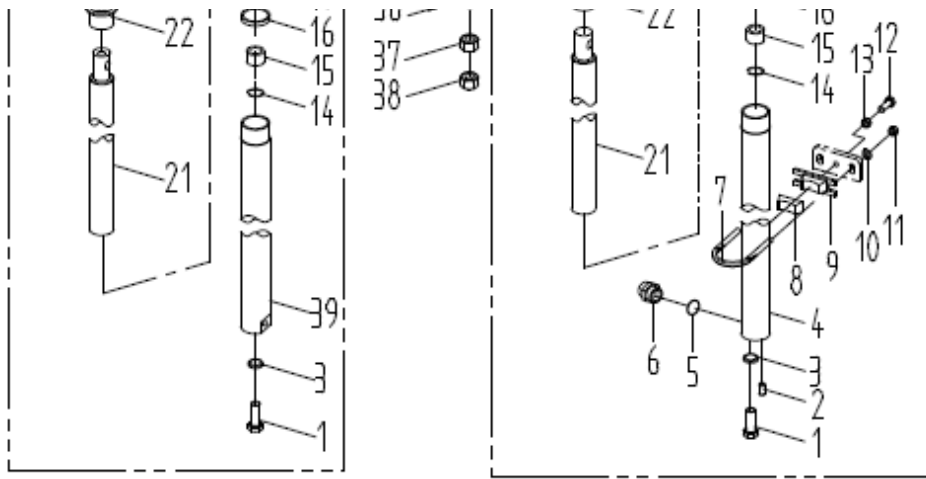



7	69006791	M3038000007	Hoop	2	
8	69012173	M3038000008	Rubber pad	2	
9	69012171	M3038009000	Hoop seat	2	
10	69000250	GB/T97.1-10	Washer 10	4	
11	69000313	GB/T6171-M10*1.25-8J	Nut M10×1.25	4	
12	69000140	GB/T5786-M12*1.25*45-8.8J	Bolt M12×1.25×45	2	
13	69000314	GB/T6171-M12*1.25-8J	Nut M12×1.25	2	
14	69130898	GB/T895.1-30	Snap ring d30	4	
15	69136215	TLC-30T03A	Sleeve	2	
16	69135377	A20480-05008	Packing 50×40×6	2	FBA20/25-JZ
-	69135450	A30480-06010	Packing 56×45×7	2	FBA30/35-JZ

图61/Fig. 61

后起升油缸(三级全自由)/REAR LIFT CYLINDER(FULL FREE 3-STAGE MAST)

FBA20/25/30/35-JZ

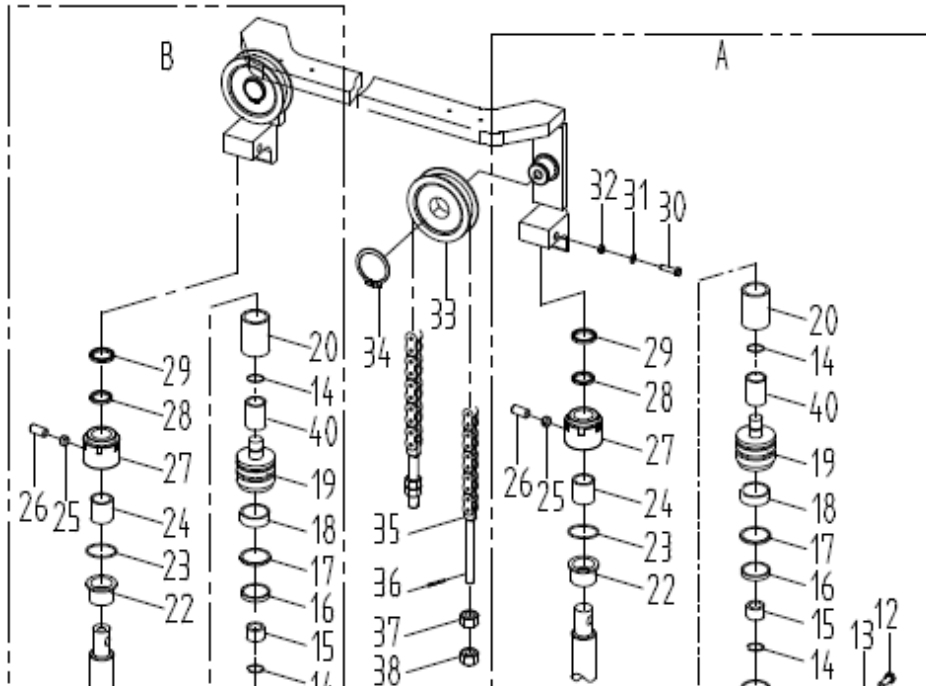

序号	物料号	代号	名称	数量	备注
Item No.	ID.	Part No.	Description	Q'ty	Remark
17	69136175	Max202J01A-001	Snap ring Φ50×Φ40×3	2	FBA20/25-JZ
-	69135449	A30480-06009	Snap ring Φ56×Φ45×3	2	FBA30/35-JZ
18	69136174	Max202J01A-002	Bearing ring D50×8×2.5	2	FBA20/25-JZ
-	69020038	LS20038	Bearing ring D56×8×2.5	2	FBA30/35-JZ
19	69135374	A20480-05005	Piston	2	FBA20/25-JZ
-	69135445	A30480-06005	Piston	2	FBA30/35-JZ
20	69136216	Max203J01-2	Sleeve	2	FBA20/25-JZ
-	69136825	Max303J01-2	Sleeve	2	FBA30/35-JZ
21	N/A	Max203J01-1	Piston rod	2	FBA20/25-JZ
-	N/A	Max303J01-1	Piston rod	2	FBA30/35-JZ
22	69135373	A20480-05004	Sleeve	2	FBA20/25-JZ
-	69135444	A30480-06004	Sleeve	2	FBA30/35-JZ
23	69023164	GB/T1235-60*3.1	O-ring 60×3.1	2	FBA20/25-JZ
-	69009541	LS9541	O-ring 68×3.1	2	FBA30/35-JZ
24	69135380	A20480-05011	Bushing Bearing 40×44×30	2	FBA20/25-JZ

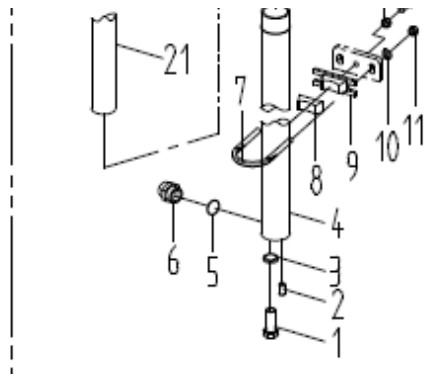
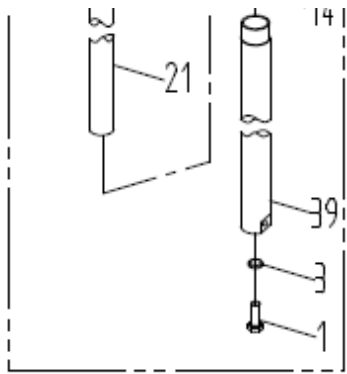

-	69135453	A30480-06013	Bushing Bearing 45×50×30	2	FBA30/35-JZ
25	69135454	A30480-06014	Nylon pad Φ6×3	2	
26	69008637	GB/T77-M8*8-12.9J	Hexagon bolt M8×8	2	
27	69135372	A20480-05003	Cylinder cap	2	FBA20/25-JZ
-	69135443	A30480-06003	Cylinder cap	2	FBA30/35-JZ
28	69135378	A20480-05009	Axis seal 40×50×7	2	FBA20/25-JZ
-	69135451	A30480-06011	Axis seal 45×55×7	2	FBA30/35-JZ
29	69135379	A20480-05010	Dustproof seal 40×52×7/10	2	FBA20/25-JZ
-	69135452	A30480-06012	Dustproof seal 45×57×7/10	2	FBA30/35-JZ
30	69003602	GB/T5785-M14*1.5*80-8.8J	Bolt M14×1.5×80	2	

图61/Fig. 61

后起升油缸(三级全自由)/REAR LIFT CYLINDER(FULL FREE 3-STAGE MAST)

FBA20/25/30/35-JZ

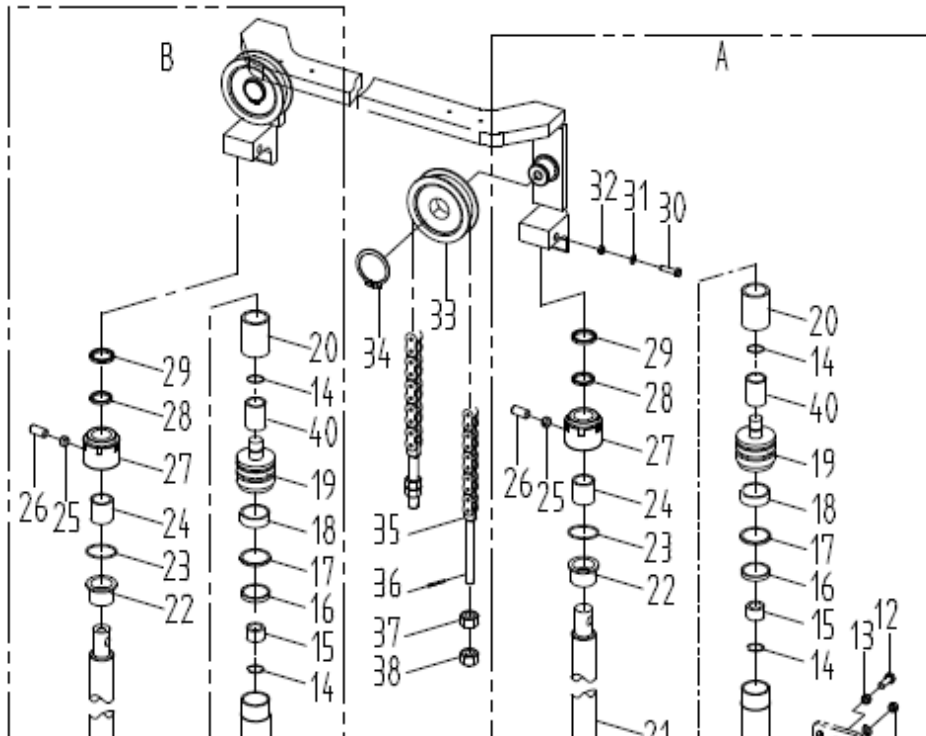

序号	物料号	代号	名称	数量	备注
Item No.	ID.	Part No.	Description	Q'ty	Remark
31	69003602	GB/T5785-M14*1.5*80-8.8J	Washer 14	2	
32	69000316	GB/T6171-M14*1.5-8J	Nut 14×1.5	2	
33	69009020	M30074007000	Chain roller 780708H	2	FBA20/25/30-JZ
-	69007748	M3538006000	Chain roller A60309	2	FBA35-JZ
34	69000070	GB/T894.1-Φ40	Snap ring 40	2	
35	N/A	A25784-01000	Chain ass'y LH1234	2	FBA20/25-JZ
-	N/A	A30784-01000	Chain ass'y LH1623	2	FBA30-JZ
-	N/A	A35784-01000	Chain ass'y LH1634	2	FBA35-JZ
36	69017915	GB/T91-3.2*40	Cotter pin 3.2×40	4	
37	69107732	M3038001001	Nut M18×1.5	4	FBA20/25/30-JZ
-	69012580	M3538001001	Nut M22×1.5	4	FBA35-JZ
38	69000004	GB/T6171-M18*1.5-8J	Nut M18×1.5	4	FBA20/25/30-JZ
-	69136816	GB/T6171-2000-M22*1.5	Nut M22×1.5	4	FBA35-JZ
39	N/A	Max203J01A-100	Cylinder body (left)	1	FBA20/25-JZ
-	N/A	Max303J01A-100	Cylinder body (left)	1	FBA30/35-JZ
40	69135384	A20480-05200	One way valve	1	















图62/FIG. 62

倾斜油缸/TILT CYLINDER

FBA15/18-JZ

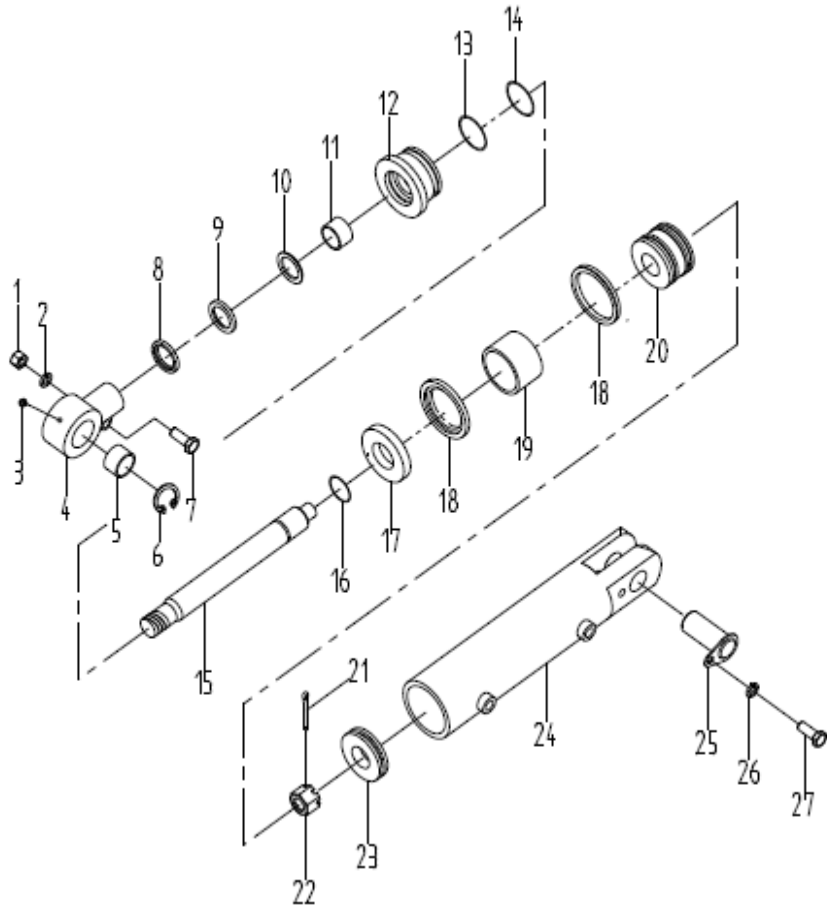

序号	物料号	代号	名称	数量	备注
Item No.	ID.	Part No.	Description	Q'ty	Remark
A	N/A	A15780-03000	Tilt cylinder(right)	2	
1	69000315	GB/T6171-M12*1.5-8J	Nut M12×1.5	2	
2	69000054	GB/T93-12	Washer 12	2	
3	69003941	JB/T7940.1-M10*1	Nipple M10×1	2	
4	69139923	A15780-03001	Connect ring	2	
5	69135422	A30480-05013	Oscillating bearing GE30ES	2	
6	69135424	A30480-05015	Orifice circlip D47	2	
7	69000139	GB/T5786-M12*1.25*40-8.8J	Bolt M12×1.5×40	2	
8	69008949	LS8949	Dustproof seal d30×38×5/6.5	2	
9	69139924	A15780-03002	Snap spring φ30×φ40×3	2	
10	69139925	A15780-03003	Packing φ30×φ40×6	2	
11	69139926	A15780-03004	Bush bearing 30×34×30	2	
12	69139927	A15780-03005	Cylinder cap	2	
13	69139928	A15780-03006	Snap spring φ63×φ58.5×1.5	2	
14	69009554	LS9554	O-ring 63×3.1	2	
15	N/A	MS15385-1	Piston rod	2	
16	69124131	GB1235-22*2.4-G	O-ring 22×2.4	2	
17	69139929	A15780-03007	Sleeve	2	
18	69135507	A35480-04011	Packing 63×53×6	4	
19	69139931	A15780-03008	Bush bearing ring D63×15.7×2.5	2	
20	69139932	A15780-03009	Piston	2	
21	69010316	GB/T91-2000 4*40	Cotter pin 4×40	2	
22	69023117	GB/T9458-M20*2	Nut M20×2 δ 20	2	



图62/FIG. 62

倾斜油缸/TILT CYLINDER

FBA15/18-JZ

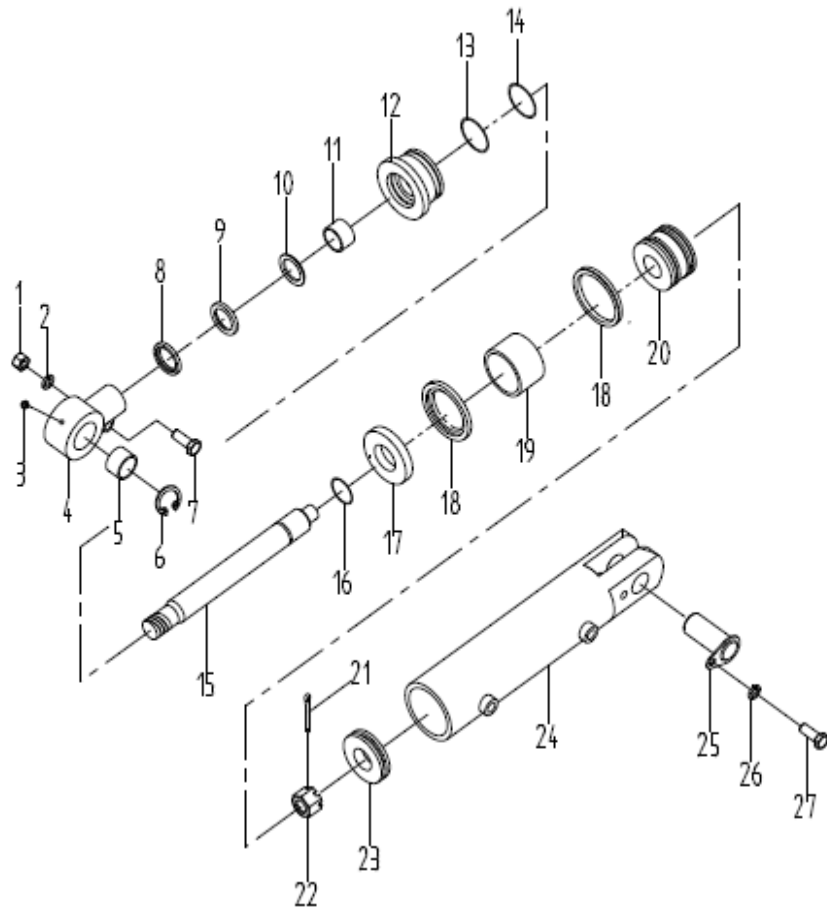

1.5-1.8t倾斜升油缸选用表 TILT CYLINDER OPTION TABLE

前后/ 倾角 Tilt angle	物料号	倾斜缸 Tilt cylinder	起升高度 Lifting Height
	ID.		
5° /10°	69065453	A15780-03000-5-10°	$h \leq 4\text{m}$
5° /6°	69065454	A15780-03000-5-6°	$4\text{m} < h \leq 5\text{m}$
3° /6°	69065455	A15780-03000-3-6°	$h > 5\text{m}$

图63/FIG. 63

倾斜油缸/TILT CYLINDER

FBA20/25-JZ

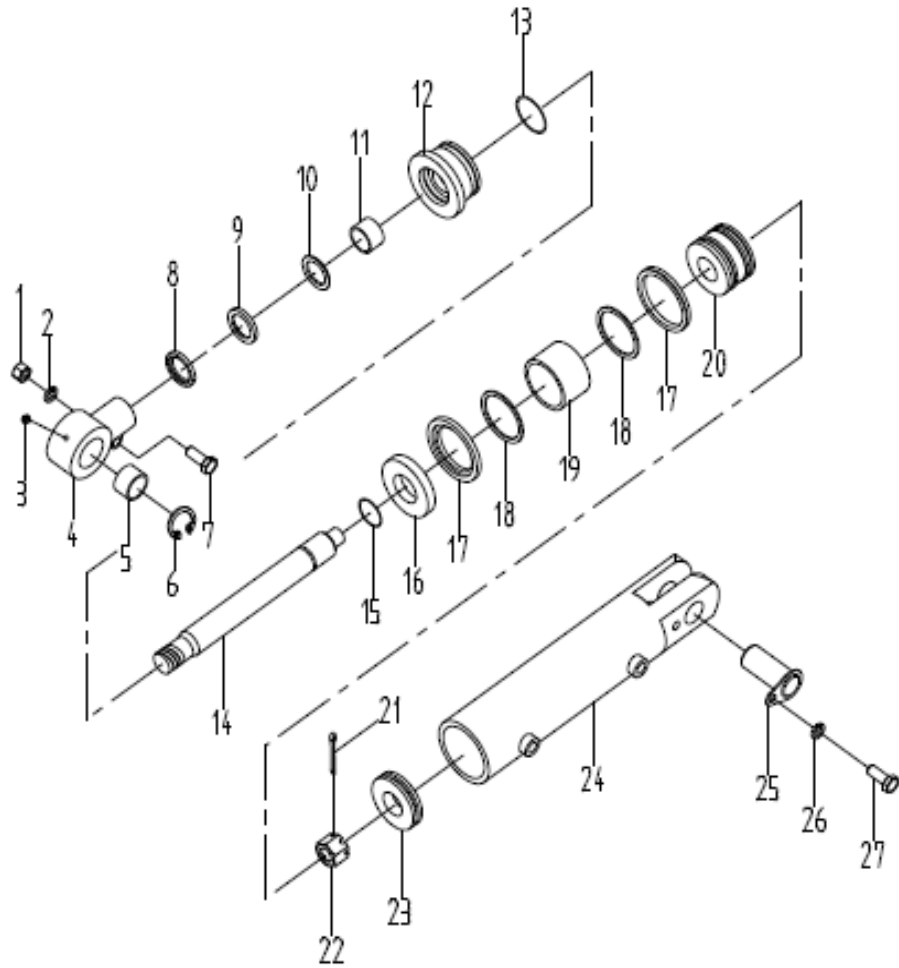

序号	物料号	代号	名称	数量	备注
Item No.	ID.	Part No.	Description	Q'ty	Remark
-	N/A	A25780-03000	Tilt cylinder	2	
01	69000316	GB/T6171-M14*1.5-8J	Nut M14×1.5 δ 13	2	
02	69005111	GB/T93-14	Washer 14	2	
03	69003941	JB/T7940.1-M10*1	Nipple M10×1	2	
04	69136461	Max030-06-1	Connect ring	2	
05	69135422	A30480-05013	Oscillating bearing GE30ES	2	
06	69135424	A30480-05015	Orifice circlip D47	2	
07	69136826	GB/T5786-M14*1.5*55	Bolt M14×1.5×55	2	
08	69135349	A20480-04009	Dustproof seal d32×40×5/6.5	2	
09	69136160	Max020-06-001	Snap ring φ48×φ32×3	2	
10	69135347	A20480-04007	Axis seal φ32×φ42×6	2	
11	69135350	A20480-04010	Bush bearing 32×36×35	2	
12	69135351	A20480-04011	Guiding bushing 70	2	
13	69002386	LS2386	O-ring 70×5.7	2	
14	69136465	Max020-06-1D	Piston rod	2	
15	69002382	LS2382	O-ring 38×3.5	2	
16	69136202	M20385-2	Spacer I	2	
17	69135348	A20480-04008	Packing D70×60×6	4	
18	69135345	A20480-04005	Snap ring D70×φ60×2.5	4	
19	69135343	A20480-04003	Bearing ring D70×16×2.5	2	
20	69135352	A20480-04012	Piston	2	
21	69136827	GB91-86-5×40	Cotter pin 5×40	2	
22	69012580	M3538001001	Nut M22×1.5 δ 22	2	
23	69136161	Max020-06-2	Spacer	2	
24	69136466	Max020-06-100D	Cylinder body	2	

图63/FIG. 63

倾斜油缸/TILT CYLINDER

FBA20/25-JZ

序号	物料号	代号	名称	数量	备注
----	-----	----	----	----	----

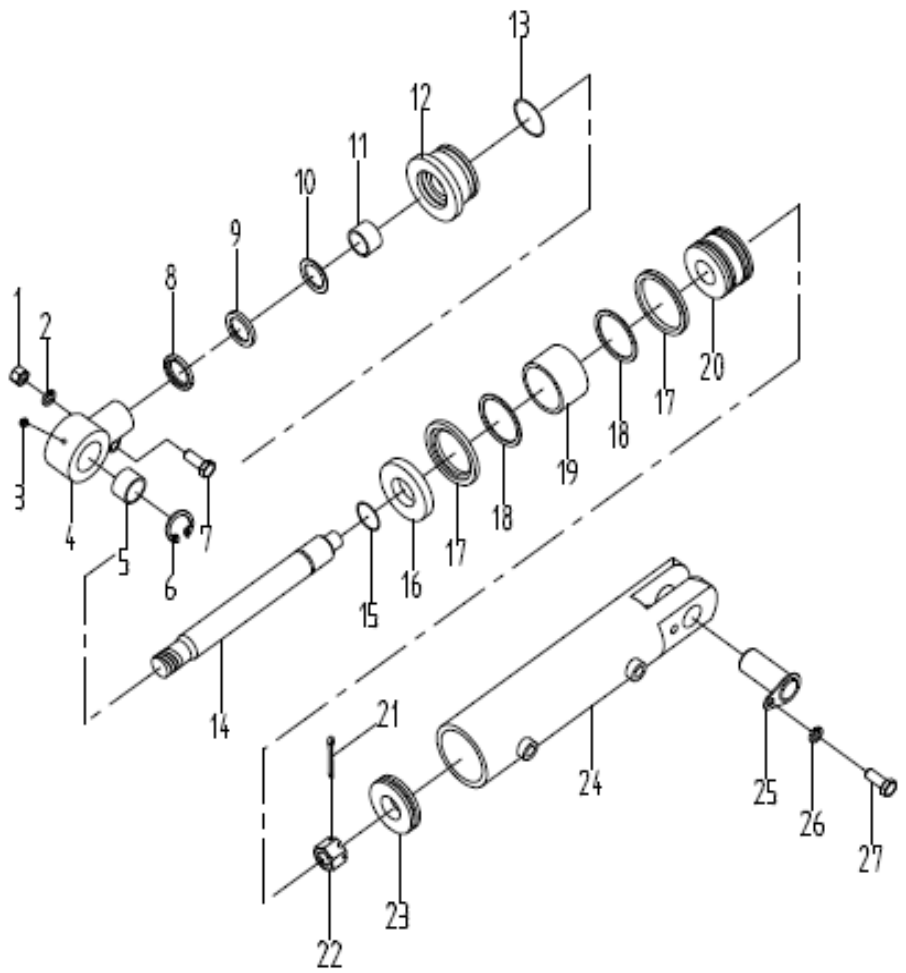

Item No.	ID.	Part No.	Description	Q'ty	Remark
25	69034184	A30480-09000	Pin shaft	2	
26	69000053	GB/T93-10	Washer 10	2	
27	69000123	GB/T5783-M10*20-8.8J	Bolt M10×20	2	

图63/FIG. 63 倾斜油缸/TILT CYLINDER

FBA20/25-JZ

2-2.5t倾斜升油缸选用表 TILT CYLINDER OPTION TABLE

前后/倾角	物料号	倾斜缸	起升高度

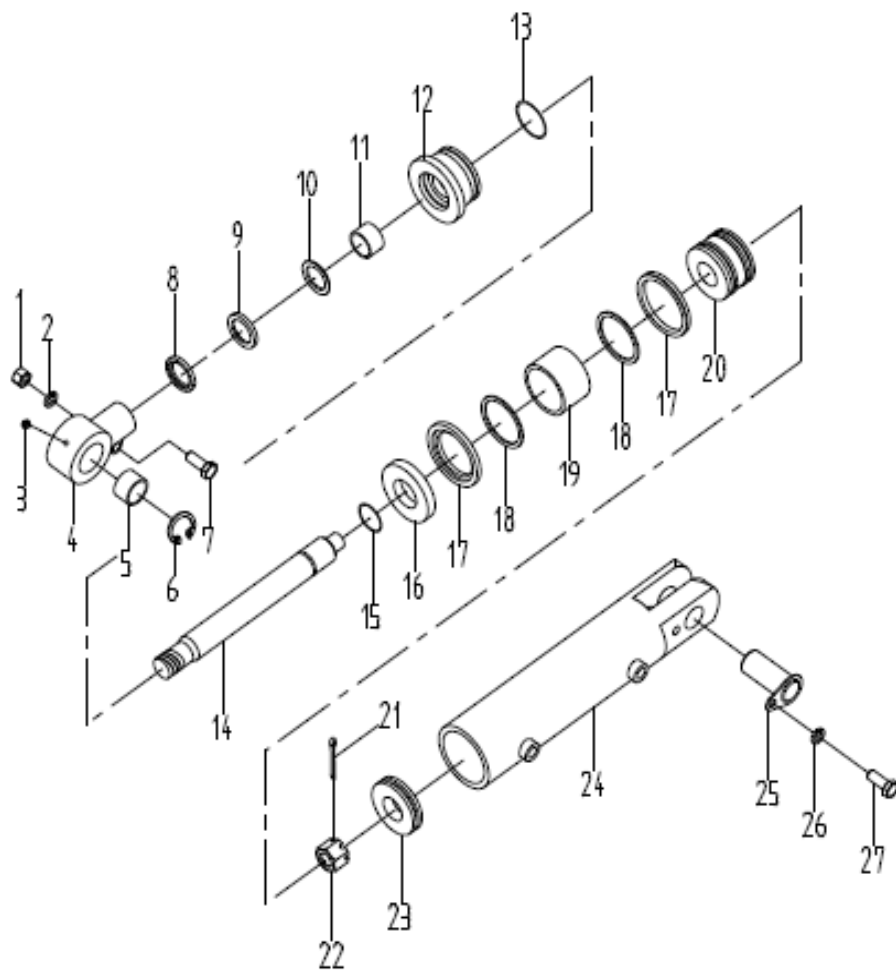

Tilt angle	ID.	Tilt cylinder		Lifting Height
5° /10°	69065000	A25780-03000-5-10°		$h \leq 4m$
5° /6°	69065036	A25780-03000-5-6°		$4m < h \leq 5m$
3° /6°	69065037	A25780-03000-3-6°		$h > 5m$

图64/FIG. 64 倾斜油缸/TILT CYLINDER

FBA30/35-JZ

序号	物料号	代号	名称	数量	备注
Item No.	ID.	Part No.	Description	Q' ty	Remark
-	N/A	A30780-03000	Tilt cylinder	2	
01	69000316	GB/T6171-M14*1.5-8J	Nut M14×1.5 δ13	2	



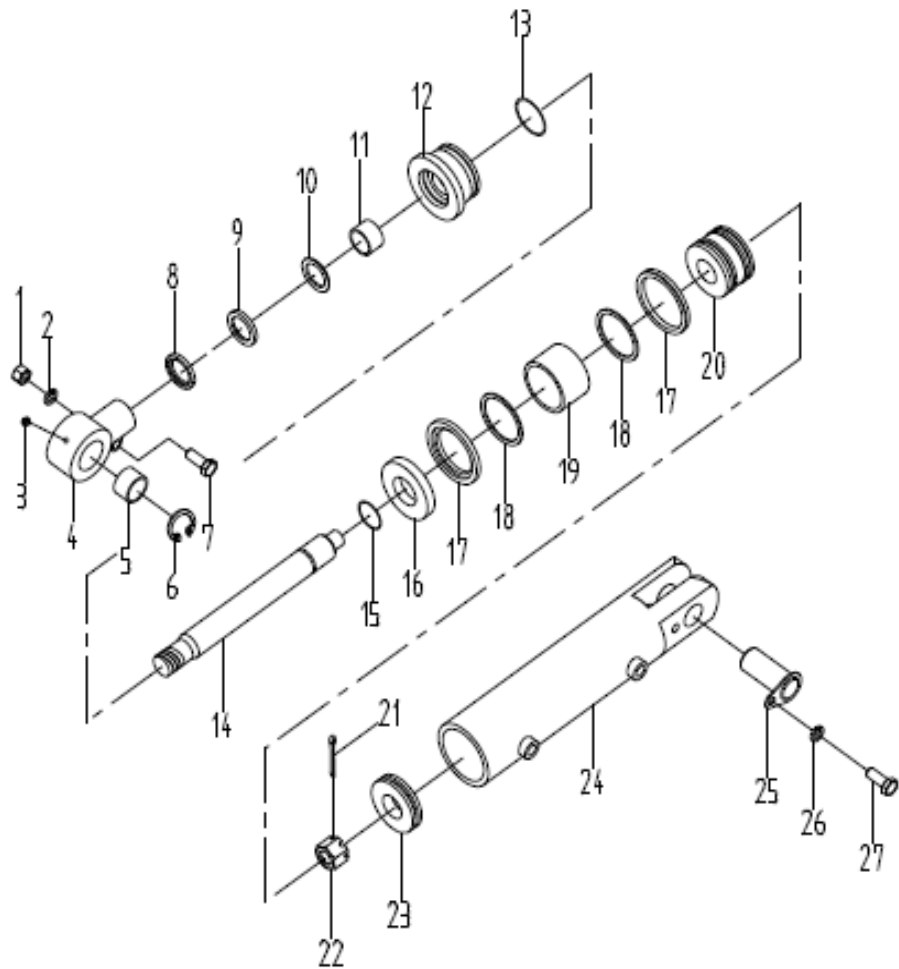

02	69005111	GB/T93-14	Washer 14	2	
03	69003941	JB/T7940.1-M10*1	Nipple M10×1	2	
04	69136461	Max030-06-1	Connect ring	2	
05	69135422	A30480-05013	Oscillating bearing GE30ES	2	
06	69135424	A30480-05015	Clip spring D47	2	
07	69136826	GB/T5786-M14*1.5*55	Bolt M14×1.5×55	2	
08	69135421	A30480-05012	Dust-proof seal d35×43×5/6.5	2	
09	69135416	A30480-05007	Snap ring φ45×φ35×3	2	
10	69135419	A30480-05010	Packing 35×45×6	2	
11	69135423	A30480-05014	Bush bearing 35×39×35	2	
12	69135412	A30480-05003	Guiding bushing 80	2	
13	69002387	LS2387	O-ring 80×5.7	2	
14	69136464	M030-06-4D	Piston rod	2	
15	69002383	LS2383	O-ring 41×3.5	2	
16	69136457	Max030-06-2	Spacer I	2	
17	69135420	A30480-05011	Packing D80×70×6	4	
18	69135417	A30480-05008	Snap ring φ80×φ70×2.5	4	
19	69135415	A30480-05006	Bearing ring D80×16×2.5	2	
20	69135413	A30480-05004	Piston 80	2	
21	69007675	GB/T91-5*45	Cotter pin 5×45	2	
22	69094105	GB/T9459-1988	Nut 27×2 δ 27	2	
23	69136830	Max030-06-3	Spacer II	2	
24	69136467	Max030-06-100D	Cylinder body	2	

图64/FIG. 64

倾斜油缸/TILT CYLINDER

FBA30/35-JZ

序号	物料号	代号	名称	数量	备注
Item No.	ID.	Part No.	Description	Q'ty	Remark
25	69034184	A30480-09000	Pin shaft	2	
26	69000053	GB/T93-10	Washer 10	2	
27	69000123	GB/T5783-M10*20-8.8J	Bolt M10×20	2	





图64/FIG. 64 倾斜油缸/TILT CYLINDER

FBA30/35-JZ

3-3.5t倾斜油缸选用表 TILT CYLINDER OPTION TABLE

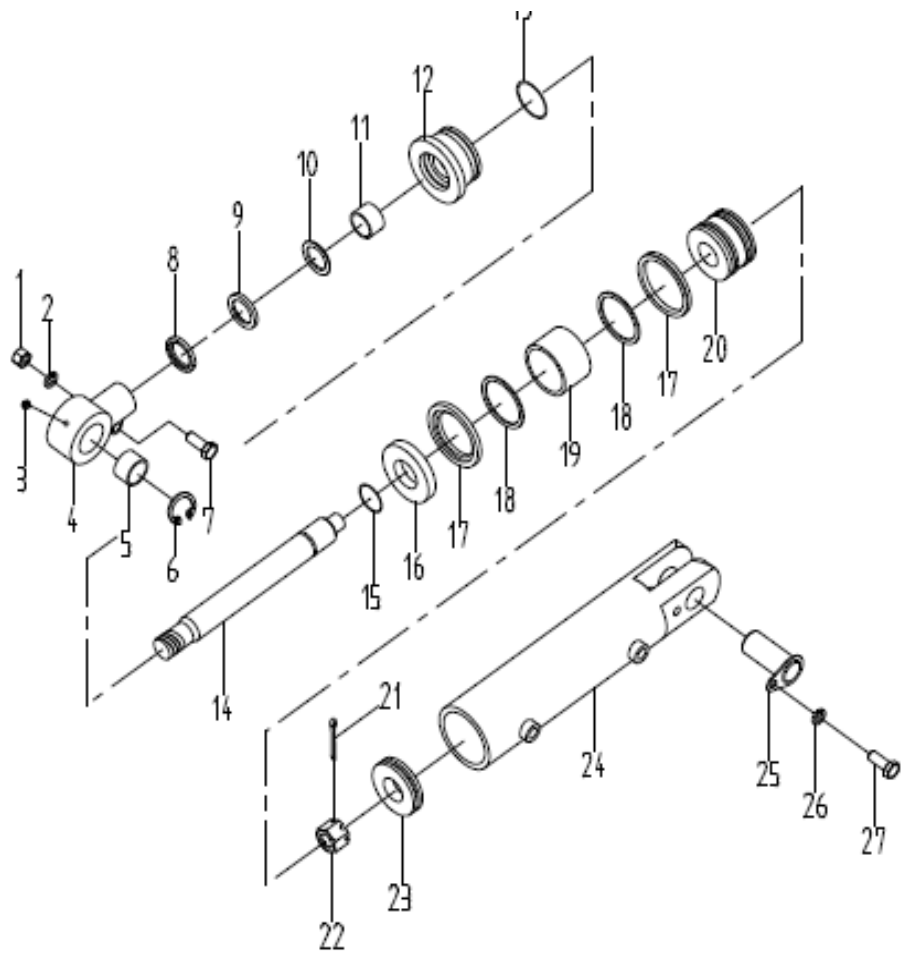
前后/ 倾角 Tilt angle	物料号 ID.	倾斜缸 Tilt cylinder	起升高度 Lifting Height
5° /10°	69065040	A30780-03000-5-10°	$h \leq 4m$
5° /6°	69065041	A30780-03000-5-6°	$4m < h \leq 5m$
3° /6°	69065042	A30780-03000-3-6°	$h > 5m$





图65/FIG. 65 门架管路系统(基本型)/HYDRAULIC SYSTEM MAST(NORMAL MAST)

FBA15/18/20/25/30/35-JZ

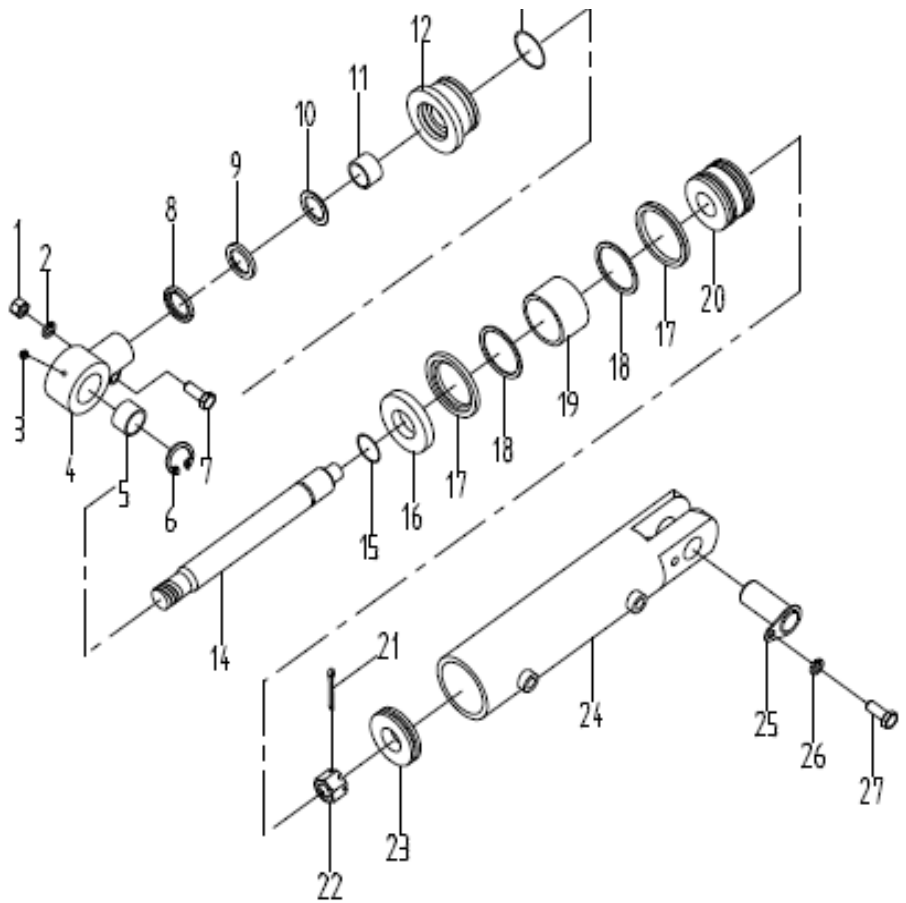
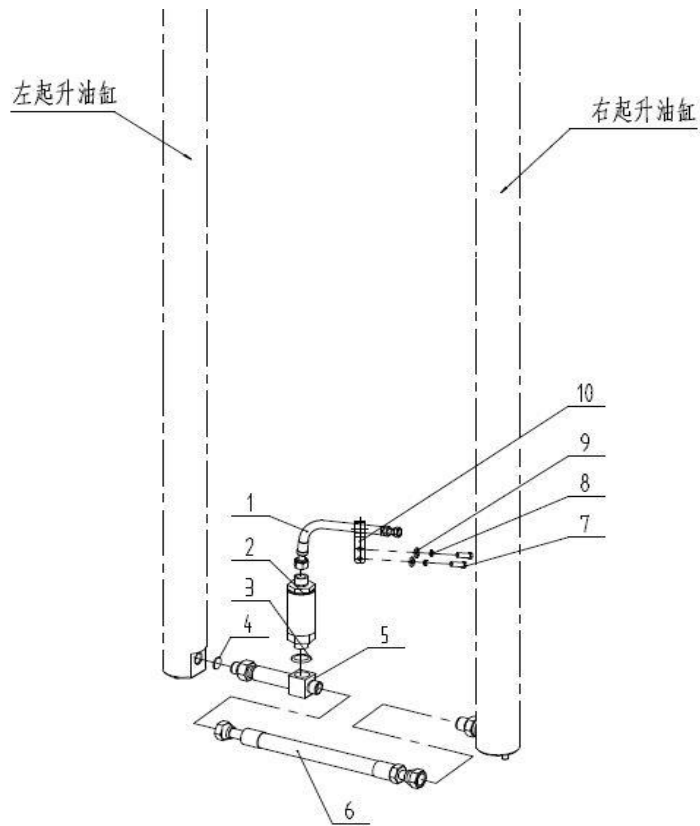

序号	物料号	代号	名称	数量	备注
Item No.	ID.	Part No.	Description	Q'ty	Remark
A	N/A		Mast hydraulic system	1	FBA15/18/20/25/30/35-JZ
01	69022704	45776-00008	H.P. hose	1	FBA15/18-JZ
-	69064580	A25786-00001	Flow regulator H.P. hose	1	FBA20/25/30/35-JZ
02	69002918	15386-01000	Speed limiting valve	1	FBA15/18-JZ
-	69002920	20386-01000	Speed limiting valve	1	FBA20/25-JZ
-	69002922	30386-03000	Speed limiting valve	1	FBA30-JZ



-	69002923	35386-02000	Speed limiting valve	1	FBA35-JZ
03	69022457	GB/T1235-24*2.4	O-ring 24×2.4	1	
04	69124142	GB/T3452.1-17*2.65-G	O-ring 17×2.65	1	
05	69016646	30386-01000	Lift cylinder tee connector	1	
06	69020534	15386-00001	H. P. hose	1	FBA15/18-JZ
-	69130621	A20488-00001	H. P. hose	1	FBA20/25-JZ
-	69121326	A30786-00001	H. P. hose	1	FBA30/35-JZ
07	69000190	GB/T5783-M6*16-8.8J	Bolt M6×16	2	
08	69000060	GB/T93-6	Spring washer 6	2	
09	69000258	GB/T97.1-6	Washer 6	2	
10	69057149	20B88-00001	Pipe clamp	1	

图66/FIG. 66 门架管路系统(基本型三联)/MAST HYDRAULIC SYSTEM(NORMAL MAST Three-THROW)

FBA15/18/20/25/30/35-JZ

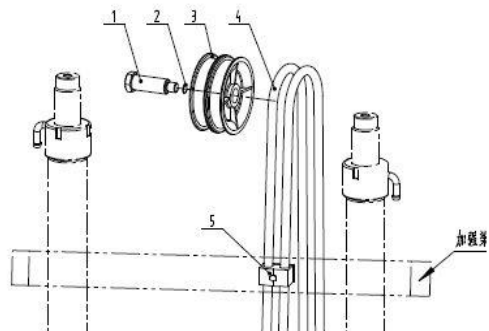

序号	物料号	代号	名称	数量	备注
Item No.	ID.	Part No.	Description	Q'ty	Remark
A	N/A		Mast hydraulic system	1	FBA15/18/20/25/30/35-JZ
1	69016660	30386S-00003	Step bolt	1	
2	69000579	30386S-00004 (8)	Sleeve II	3	
3	69016659	30386S-00002	Pulley	2	
4	N/A	A15786S-01000	H. P. hose	2	FBA15/18-JZ
-	N/A	A25786S-01000	H. P. hose	2	FBA20/25/30-JZ
-	N/A	A35786S-01000	H. P. hose	2	FBA35-JZ

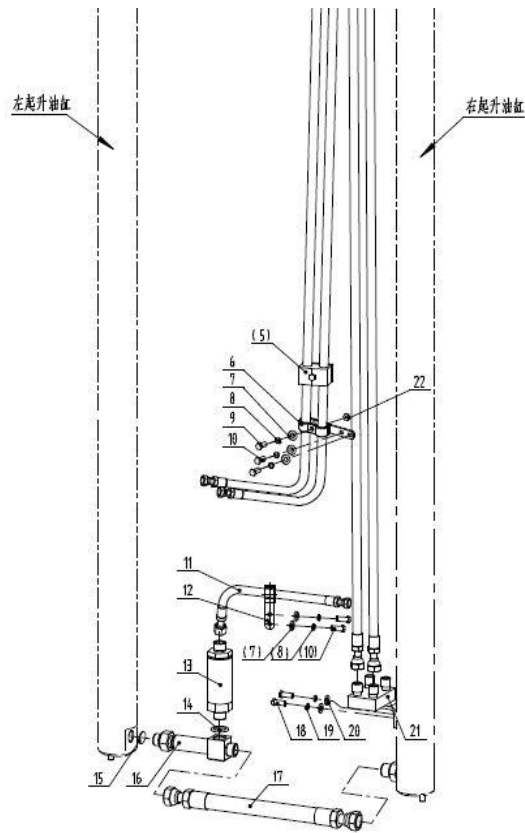

5	69069602	S30488S-00003	Pipe clamp	1/2/3	<4/≥4m/≥5.5m
6	69057150	20B88S-00001	Pipe clamp	1	
7	69000258	GB/T97.1-6	Washer 6	5	
8	69000060	GB/T93-6	Washer 6	5	
9	69000194	GB/T5783-M6*25-8.8J	Bolt M6×25	1	
10	69000189	GB/T5783-M6*12-8.8J	Bolt M6×12	4	
11	69022704	45776-00008	H. P. hose	1	FBA15/18-JZ
-	69064580	A25786-00001	Adjusting pipe H. P. hose	1	FBA20/25/30/35-JZ
12	69057149	20B88-00001	Pipe clamp	1	
13	69002918	15386-01000	Flow regulator	1	FBA15/18-JZ
-	69002920	20386-01000	Speed limiting valve	1	FBA20/25-JZ
-	69002922	30386-03000	Speed limiting valve	1	FBA30-JZ
-	69002923	35386-02000	Speed limiting valve	1	FBA35-JZ
14	69022457	GB/T1235-24*2.4	O-ring 24×2.4	1	
15	69124142	GB/T3452.1-17*2.65-G	O-ring 17×2.65	1	
16	69016646	30386-01000	Lift cylinder tee connector	1	
17	69020534	15386-00001	H. P. hose	1	FBA15/18-JZ
-	69130621	A20488-00001	H. P. hose	1	FBA20/25-JZ

图66/FIG. 66

门架管路系统(基本型三联)/MAST HYDRAULIC SYSTEM(NORMAL MAST Three-THROW)

FBA15/18/20/25/30/35-JZ

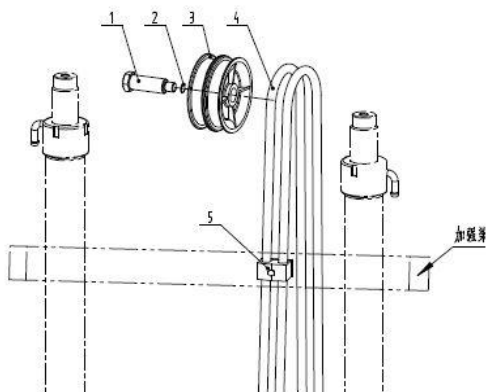

序号	物料号	代号	名称	数量	备注
Item No.	ID.	Part No.	Description	Q'ty	Remark
-	69121326	A30786-00001	H. P. hose	1	FBA30/35-JZ
18	69000309	GB/T5783-M8*16-8.8J	Bolt M8×16	2	
19	69000062	GB/T93-8	Washer 8	2	
20	69000259	GB/T97.1-8	Washer 8	2	
21	69012313	30386S-03000	Four way I	1	FBA15/18/30-JZ
-	69064637	A25786S-02000	Four way	1	FBA20/25-JZ
-	69020958	35386S-02000	Four way I	1	FBA35-JZ
22	69000111	GB/T6170-M6-8J	Nut M6	1	





图66/FIG. 66 门架管路系统(基本型三联)/MAST HYDRAULIC SYSTEM(NORMAL MAST Three-THROW)

FBA15/18/20/25/30/35-JZ

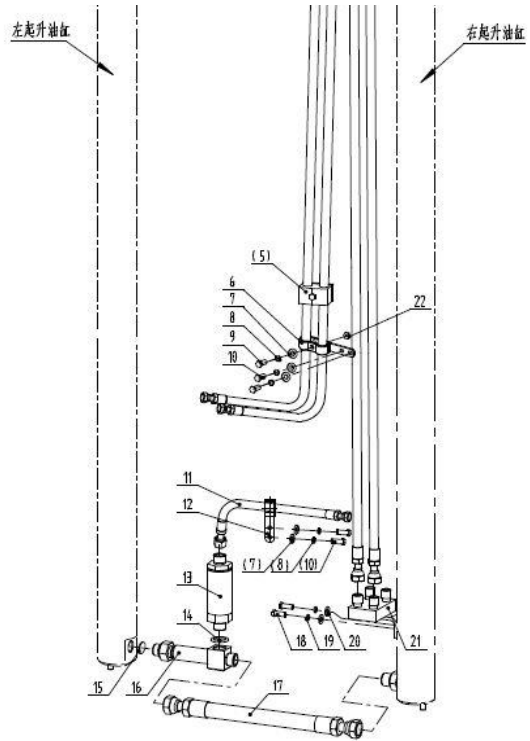
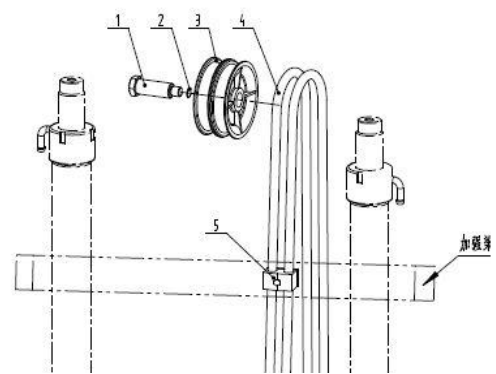

管路系统选用件(件4)  
Mast Piping Optional Parts part-4

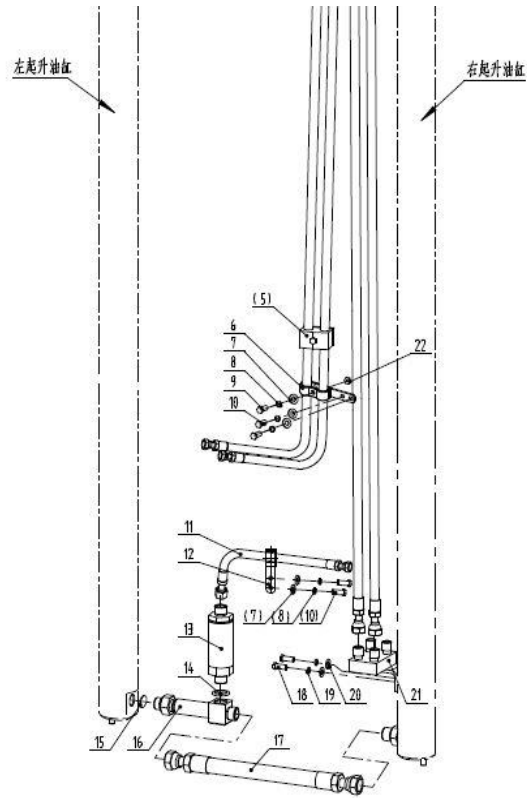
起升高度 LIFTING G	1.5-1.8t		2.0-3.0t		3.5t	
	ID.	A15786S-01000 PLASTIC HOSE	ID.	ID.	ID.	A35786S-01000 PLASTIC HOSE
2000	69016776	30388S-01004	N/A	N/A	-	-
2500	69017075	30386S-01012	69018307	6,9E+07	30386S-01012	
2700	69016809	30388SS-01008	69016780	6,9E+07	A35786S-01001	
3000	69016895	35388S-01009	69016653	6,9E+07	35388S-01009	
3300	69016908	35388SS-01009	69016810	6,9E+07	35386S-01014	
3500	69065321	35BJ86S-01001	69016654	6,9E+07	35BJ86S-01001	



3700	69018314	35386S-01016	69017067	6,9E+07	A35786S-01002
4000	69017158	35388SS-01011	69017080	6,9E+07	35388SS-01011
4250	69017081	30388SS-01012	-	-	-
4500	69018316	35386S-01018		6,9E+07	A35786S-01003
4750	69049634	40386XS-01018	-	-	-
5000	69018317	35386S-01019	69016657	6,9E+07	A35786S-01004
5500	69064698	A25786SS-01001	69064620	6,9E+07	A25786SS-01001
6000	69064700	A25786SS-01002	69064621	6,9E+07	A35786S-01005

图67/FIG. 67

门架管路系统(基本型四联)/MAST HYDRAULIC SYSTEM(NORMAL MAST Four-THROW)

FBA15/18/20/25/30/35-JZ

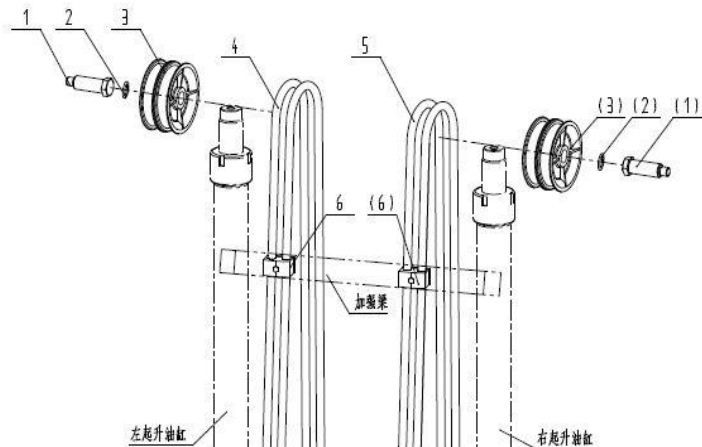

序号 Item No.	物料号 ID.	代号 Part No.	名称 Description	数量 Q'ty	备注 Remark
A	N/A		Mast hydraulic system	1	FBA15/18/20/25/30/35-JZ
1	69016660	30386S-00003	Step bolt	2	
2	69000579	30386S-00004 (8)	Sleeve II	6	
3	69016659	30386S-00002	Pulley	4	
4	N/A	A15786SS-01000	H. P. hose	2	FBA15/18-JZ
-	N/A	A25786SS-01000	H. P. hose	2	FBA20/25/30-JZ
-	N/A	A35786SS-01000	H. P. hose	2	FBA35-JZ
5	N/A	A15786S-01000	H. P. hose	2	FBA15/18-JZ
-	N/A	A25786S-01000	H. P. hose	2	FBA20/25/30-JZ

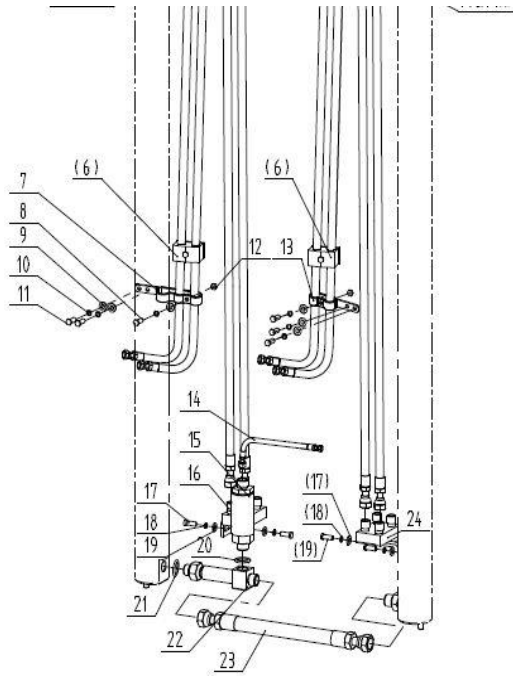

-	N/A	A35786S-01000	H. P. hose	2	FBA35-JZ
6	69069602	S30488S-00003	Pipe clamp	2/4/6	<4/≥4m/≥5.5m
7	69057151	20B88SS-00002	Pipe clamp	1	
8	69000194	GB/T5783-M6*25-8.8J	Bolt M6×25	2	
9	69000258	GB/T97.1-6	Washer6	6	
10	69000060	GB/T93-6	washer6	6	
11	69000189	GB/T5783-M6*12-8.8J	Bolt M6×12	4	
12	69000111	GB/T6170-M6-8J	Nut M6	2	
13	69057150	20B88S-00001	Pipe clamp	1	
14	69022704	45776-00008	H. P. hose	1	FBA15/18-JZ
-	69064580	A25786-00001	H. P. hose	1	FBA20/25/30/35-JZ
15	69002918	15386-01000	Speed limiting valve	1	FBA15/18-JZ
-	69002920	20386-01000	Speed limiting valve	1	FBA20/25-JZ
-	69002922	30386-03000	Speed limiting valve	1	FBA30-JZ

图67/FIG. 67

门架管路系统(基本型四联)/MAST HYDRAULIC SYSTEM(NORMAL MAST Four-THROW)

FBA15/18/20/25/30/35-JZ

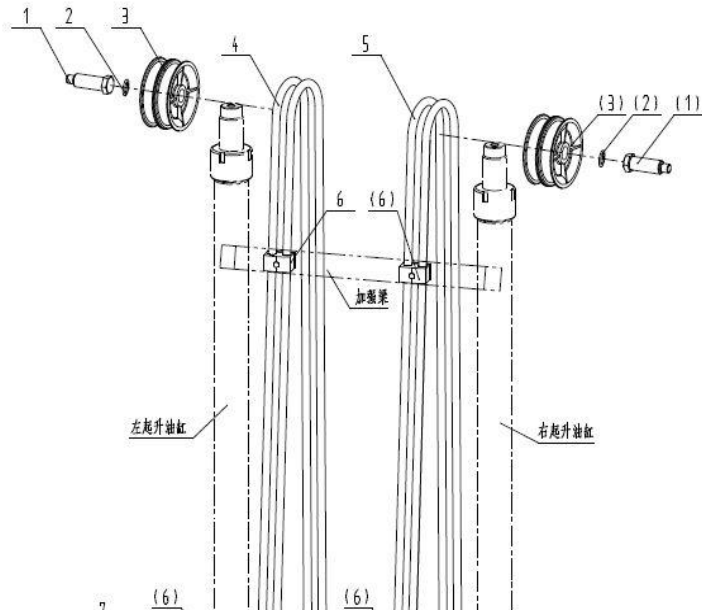

序号 Item No.	物料号 ID.	代号 Part No.	名称 Description	数量 Q' ty	备注 Remark
-	69002923	35386-02000	Flow regulator	1	FBA35-JZ
16	69012312	30386SS-01000	Four way II	1	FBA15/18/30-JZ
-	69064697	A25786SS-02000	Cross connecto	1	FBA20/25-JZ
-	69020959	35386SS-01000	Four way II	1	FBA35-JZ
17	69000259	GB/T97.1-8	washer8	12	
18	69000062	GB/T93-8	Washer 8	12	
19	69000309	GB/T5783-M8*16-8.8J	Bolt M8×16	4	
20	69022457	GB/T1235-24*2.4	O-ring 24×2.4	1	
21	69124142	GB/T3452.1-17*2.65-G	O-ring 17×2.65	1	
22	69016646	30386-01000	Lift cylinder tee connector	1	
23	69020534	15386-00001	H. P. hose	1	FBA15/18-JZ
-	69130621	A20488-00001	H. P. hose	1	FBA20/25-JZ



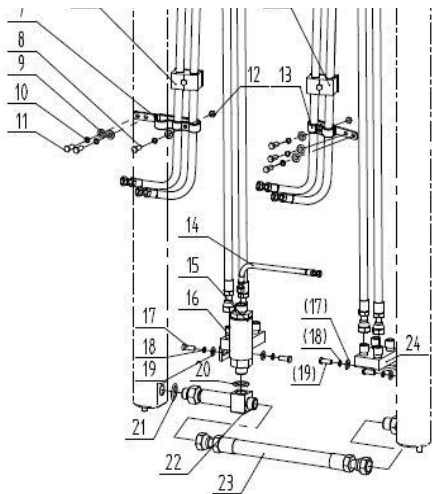

-	69121326	A30786-00001	H. P. hose	1	FBA30/35-JZ
24	69012313	30386S-03000	Four way I	1	FBA15/18/30-JZ
-	69064637	A25786S-02000	Four way	1	FBA20/25-JZ
-	69020958	35386S-02000	Four way I	1	FBA35-JZ

图67/FIG. 67 门架管路系统(基本型四联)/MAST HYDRAULIC SYSTEM(NORMAL MAST Four-THROW)

FBA15/18/20/25/30/35-JZ

管路系统选用件(件5)  
Mast Piping Optional Parts part-5

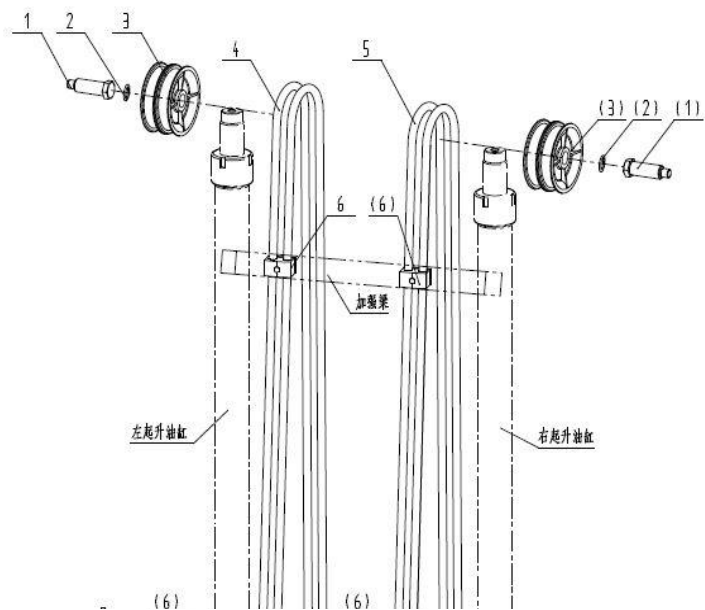

起升高度 LIFTING G	1.5-1.8t		2.0-3.0t		3.5t	
	ID.	A15786SS-01000 PLASTIC HOSE	ID.	ID.	A35786SS-01000 PLASTIC HOSE	
2000	69016651	30386S-01009	N/A	N/A	-	
2500	69016809	30388SS-01008	69018310	6,9E+07	30388SS-01008	
2700	69016895	35388S-01009	69046328	6,9E+07	30388S-01009	
3000	69016908	35388SS-01009	69016810	6,9E+07	35386S-01014	
3300	69065321	35BJ86S-01001	69016654	6,9E+07	35BJ86S-01001	
3500	69017078	30388S-01011	69017067	6,9E+07	A35786S-01002	
3700	69017080	30388SS-01011	69017078	6,9E+07	30388SS-01011	
4000	69017081	30388SS-01012	69017079	6,9E+07	30388SS-01012	
4250	69018316	35386S-01018	-	-	-	
4500	69070633	A15786SS-01001	69049634	6,9E+07	A15786SS-01001	
4750	69016657	30386S-01019	-	-	-	

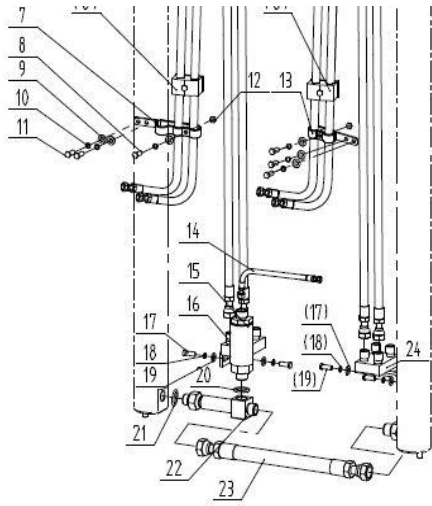

5000	69021855	40386XS-01019	69021855	6,9E+07	A35786SS-01001
5500	69064621	A25786S-01002	69064698	6,9E+07	A35786SS-01002
6000	69070634	A15786SS-01002	69064700	6,9E+07	A35786SS-01003

图68/Fig. 68 门架管路系统(两级全自由二联)/MAST HYDRAULIC SYSTEM(FULL FREE 2-STAGE MAST TWO-THROW)

FBA15/18-JZ

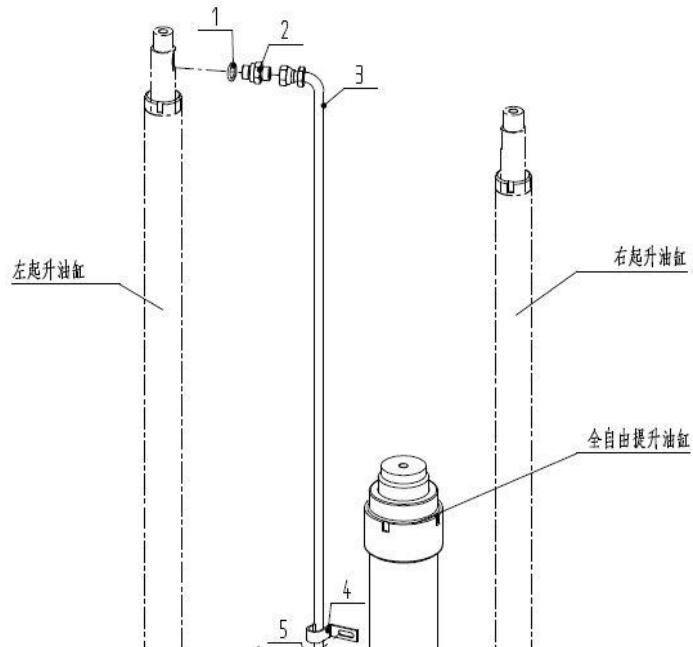

序号	物料号	代号	名称	数量	备注
Item No.	ID.	Part No.	Description	Q'ty	Remark
1	69022457	GB/T1235-24*2.4	O-ring 24×2.4	1	
2	69001443	35387-00001	Lifting cylinder connector	1	
3	N/A	20387-01000	Hose pipe assemblies	1	
4	69016689	30387-00004	Hose pipe clamp	1	
5	69000259	GB/T97.1-8	Washer 8	1	
6	69000062	GB/T93-8	Washer 8	1	
7	69000309	GB/T5783-M8*16-8.8J	Bolt M8×16	1	
8	69015804	15387-00001	Hose-Full free cylinder inlet oil hose	1	
9	69011950	20388-00001	Valve-Speed limiting valve hose II	1	
10	69005630	20386-00001	Valve-Speed limiting valve hose	1	
@	69022704	45776-00008	Steer three-way connect hose	1	
11	69012037	30387-00003	Free cylinder connector	1	取消, 厂家自带
12	69124132	GB1235-30*3.5-G	O-ring 30×3.5	1	
13	69002918	15386-01000	Speed limiting valve	1	

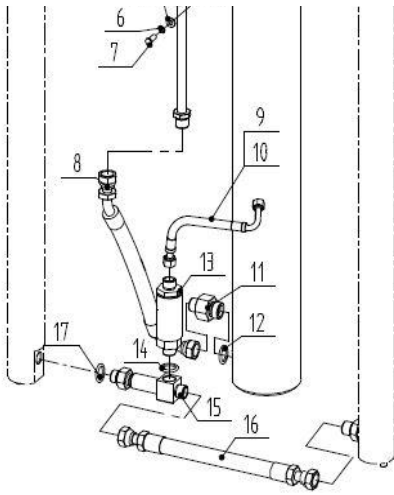

14	69022457	GB/T1235-24*2.4	O-ring 24×2.4	1	
15	69016646	30386-01000	Lifting cylinder Three way	1	
16	69020534	15386-00001	Lifting cylinder hose	1	
17	69124142	GB/T3452.1-17*2.65-G	O-ring 17×2.65	1	

图68/Fig. 68

门架管路系统(两级全自由二联)/MAST HYDRAULIC SYSTEM(FULL FREE 2-STAGE MAST TWO-THROW)

FBA15/18-JZ

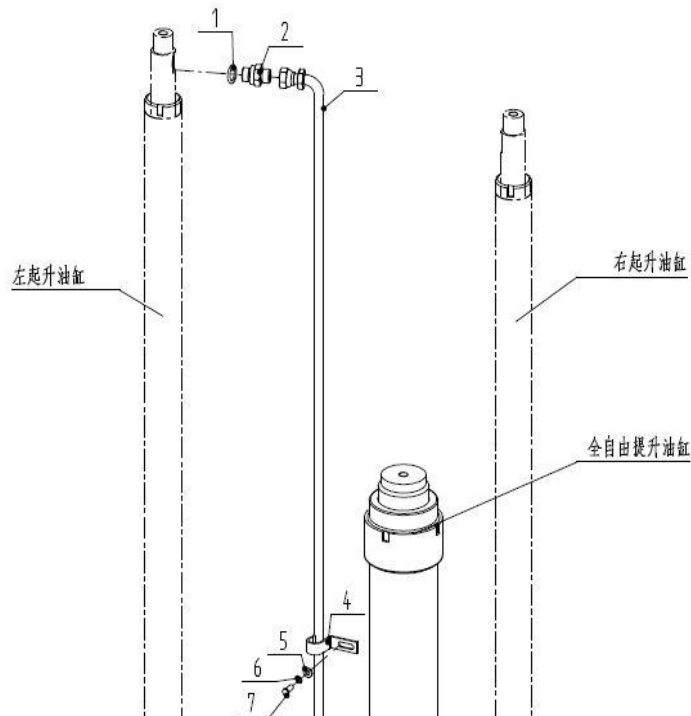

管路系统选用件(件3)  
Mast Piping Optional Parts part-3

起升高度 LIFTING G	ID.	20387-01000 Hose pipe assemblies	备注 REMARK
2000	69017018	20387-01000/1	
2500	69017019	20387-01000/2	
2700	69017020	20387-01000/3	
3000	69016583	20387-01000/4	
3300	69016584	20387-01000/5	
3500	69016585	20387-01000/6	
3600	69016586	20387-01000/7	
3700	69016587	20387-01000/8	
4000	69016588	20387-01000/9	
4500	69017022	20387-01000/11	
5000	69017024	20387-01000/13	
5500	69017025	20387-01000/14	
6000	69017026	20387-01000/15	





图69/ Fig. 69 门架管路系统(两级全自由二联)/MAST HYDRAULIC SYSTEM(FULL FREE 2-STAGE MAST TWO-THROW)

FBA20/25/30/35-JZ

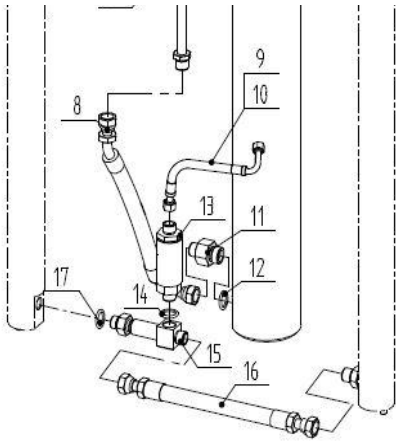
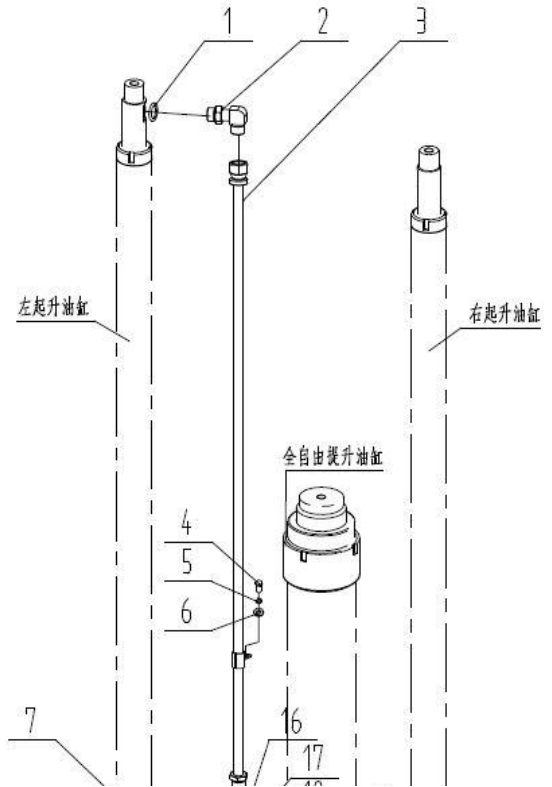
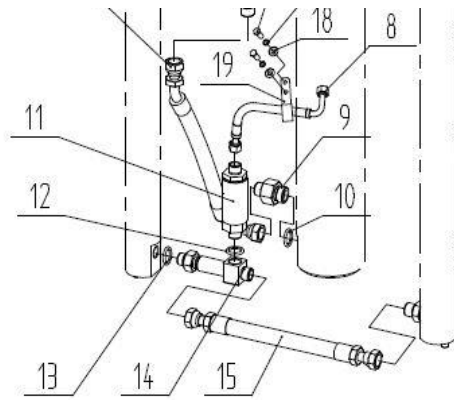

序号	物料号	代号	名称	数量	备注
Item No.	ID.	Part No.	Description	Q'ty	Remark
A	N/A		Mast hydraulic system	1	FBA20/25/30/35-JZ
1	69124144	GB/T3452.1-19*2.65-G	O-ring 19×2.65	1	
2	69003137	M3077601000	Pipe connector	1	
3	N/A	A20487-01000	Pipe ass'y	1	FBA20/25-JZ
-	N/A	A30487-02000	Pipe ass'y	1	FBA30-JZ
-	N/A	A35487-01000	Pipe ass'y	1	FBA35-JZ
4	69000309	GB/T5783-M8*16-8.8J	Bolt M8×16	1	
5	69000259	GB/T97.1-8	washer 8	1	
6	69000062	GB/T93-8	Washer 8	1	
7	69015804	15387-00001	Middle cylinder H.P. hose	1	FBA20/25/30-JZ
-	69016686	30387-00001	Middle cylinder H.P. hose	1	FBA35-JZ
8	69022704	45776-00008	Flow regulator H.P. hose II	1	
9	69012037	30387-00003	Middle cylinder connector	1	取消, 厂家自带
10	69124132	GB1235-30*3.5-G	O-ring 30×3.5	1	
11	69002920	20386-01000	Speed limiting valve	1	FBA20/25-JZ
-	69002922	30386-03000	Speed limiting valve	1	FBA30-JZ



-	69002923	35386-02000	Speed limiting valve	1	FBA35-JZ
12	69022457	GB/T1235-24*2.4	Speed limiting valve	1	
13	69124142	GB/T3452.1-17*2.65-G	O-ring 17×2.65	1	
14	69016646	30386-01000	Lift cylinder tee connector	1	
15	69130621	A20488-00001	H.P. hose	1	FBA20/25/30-JZ
-	69121326	A30786-00001	H.P. hose	1	FBA35-JZ
16	69000190	GB/T5783-M6*16-8.8J	Bolt M6×16	2	
17	69000258	GB/T97.1-6	washer 6	2	
18	69000060	GB/T93-6	Washer 6	2	
19	69057149	20B88-00001	Pipe clamp	1	

图69/Fig. 69

门架管路系统(两级全自由二联)/MAST HYDRAULIC SYSTEM(FULL FREE 2-STAGE MAST TWO-THROW)

FBA20/25/30/35-JZ

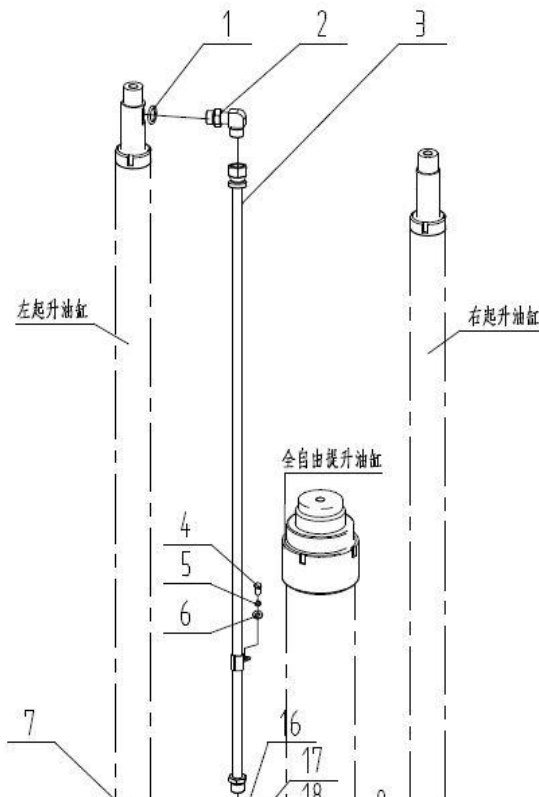

管路系统选用件 (件3)  
Mast Piping Optional Parts part-3

起升高度 LIFTING G	2.0-2.5t		3.0t	3.5t	
	ID.	A20487-01000 PLASTIC HOSE	ID.	ID.	A35487-01000 PLASTIC HOSE
3000	69055765	A20487-01001	69034174	6,9E+07	A35487-01001
3300	69055766	A20487-01002	69034175	6,9E+07	A35487-01002
3500	69055767	A20487-01003	69034176	6,9E+07	A35487-01003
3700	69055768	A20487-01004	69034177	6,9E+07	A35487-01004
4000	69055769	A20487-01005	69034178	6,9E+07	A35487-01005
4500	69055770	A20487-01006	69034179	6,9E+07	A35487-01006
5000	69055771	A20487-01007	69034180	6,9E+07	A35487-01007
5500	69055772	A20487-01008	69034181	6,9E+07	A35487-01008
6000	69055773	A20487-01009	69034182	6,9E+07	A35487-01009





图70/Fig. 70

门架管路系统(两级全自由三联)/MAST HYDRAULIC SYSTEM(FULL FREE 2-STAGE MAST THREE-THROW)

FBA15/18-JZ

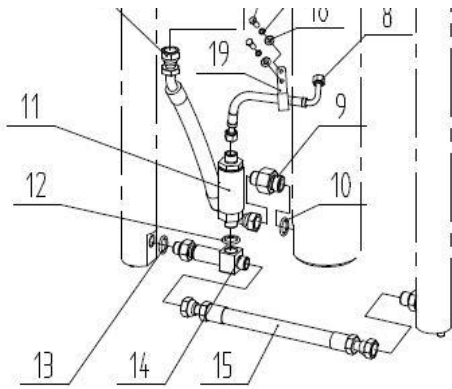
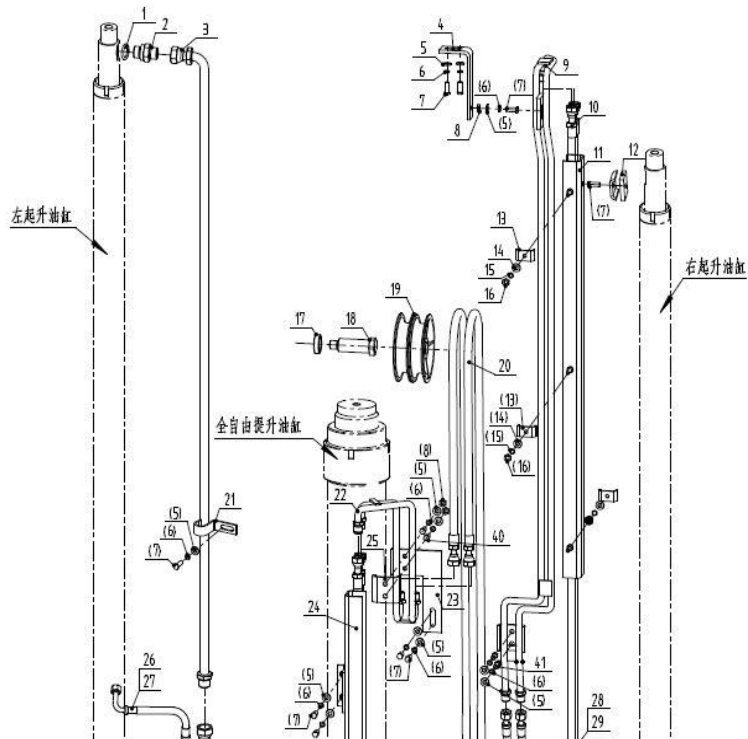

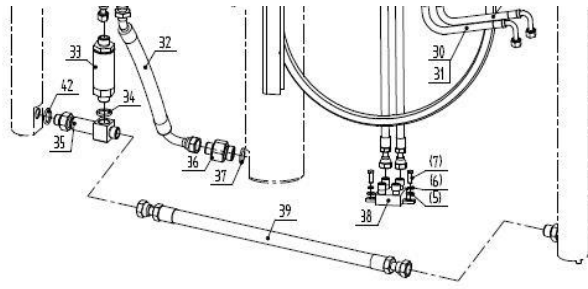
序号 Item No.	物料号 ID.	代号 Part No.	名称 Description	数量 Q'ty	备注 Remark
1	69124131	GB1235-22*2.4-G	O-ring 22×2.4	1	
2	69001443	35387-00001	Lifting cylinder connector	1	
3	N/A	20387-01000	Hose pipe assemblies	1	
4	69016706	30387S-00003	Lacating plate	1	
5	69000259	GB/T97.1-8	Washer 8	14	
6	69000062	GB/T93-8	Washer 8	14	
7	69000309	GB/T5783-M8*16-8.8J	Bolt M8×16	11	
8	69000111	GB/T6170-M6-8J	Nut M8	1	
9	N/A	15387S-01000	Guide slot hose I	1	
10	N/A	30387S-01000	Guide slot oil tube	2	
11	N/A	15387S-03000	Guide slot II	1	
12	69056648	30387S-07001	Oil tube clamp	1	
-	69056702	30387S-07002	Oil tube clamp	1	
13	69016708	30387S-00004	Hose clamp II	3	
14	69000258	GB/T97.1-6	Washer 6	3	
15	69000060	GB/T93-6	Washer 6	3	
16	69000111	GB/T6170-M6-8J	Nut M6	3	



17	69000579	30386S-00004 (8)	Sleeve	3	
18	69016660	30386S-00003	Step bolt	1	
19	69016659	30386S-00002	Pulley	2	
20	N/A	20387S-01000	Full free cylinder inlet oil hose	2	
21	69016689	30387-00004	Pipe clamp	1	
22	69015802	15387S-04000	Side shift four way I	1	
23	69016705	30387S-00002	Four way fix plate	1	
24	69046620	15387S-02000	Guide slot I	1	

图70/Fig. 70

门架管路系统(两级全自由三联)/MAST HYDRAULIC SYSTEM(FULL FREE 2-STAGE MAST THREE-THROW)

FBA15/18-JZ

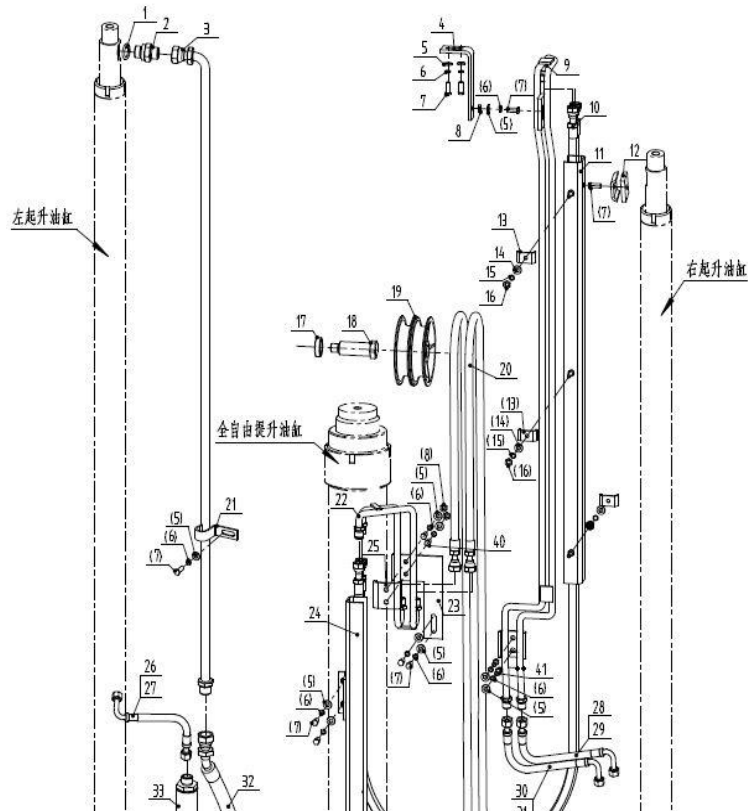

序号	物料号	代号	名称	数量	备注
Item No.	ID.	Part No.	Description	Q'ty	Remark
25	69016703	30387S-00001	Pressure pinch	1	
26	69011950	20388-00001	Valve-Speed limiting valve hose II	1	
27	69005630	20386-00001	Valve-Speed limiting valve hose II	1	
-	69022704	45776-00008	Steer three-way connect hose	1	
28	69018460	20386SS-00001	Valve-Steering hose I	1	
29	69016667	30386S-00007	Valve-Steering hose III	1	
30	69016666	30386S-00006	Valve-Steering hose II	1	
31	69016668	30386S-00008	Valve-Steering hose IV	1	
32	69016686	30387-00001	Hard hose-Full free cylinder inlet oil hose	1	
33	69002918	15386-01000	Speed limiting valve	1	
34	69022457	GB1235-24*2.4	O-ring 24×2.4	1	
35	69016646	30386-01000	Lifting cylinder Three way	1	
36	69012037	30387-00003	Free cylinder connector	1	取消, 厂家自带
37	69124132	GB1235-30*3.5-G	O-ring 30×3.5	1	
38	69012712	30387S-08000	Four way II	1	
39	69020534	15386-00001	Lifting cylinder hose	1	
40	69000206	GB/T5783-M8*40-8.8J	Bolt M8×40	2	
41	69021662	GB/T5782-M8*60-8.8J	Bolt M8×60	2	

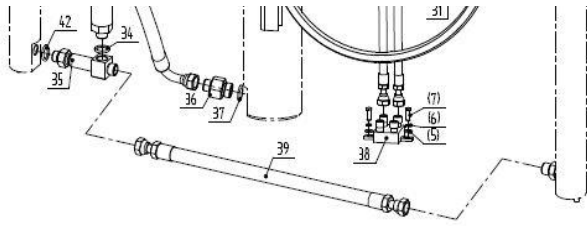

42	69124142	GB/T3452.1-17*2.65-G	O-ring 17×2.65	1	

图70/Fig. 70

门架管路系统(两级全自由三联)/MAST HYDRAULIC SYSTEM(FULL FREE 2-STAGE MAST THREE-THROW)

FBA15/18-JZ

管路系统选用件 (件9,10)  
Mast Piping Optional Parts part-9&10

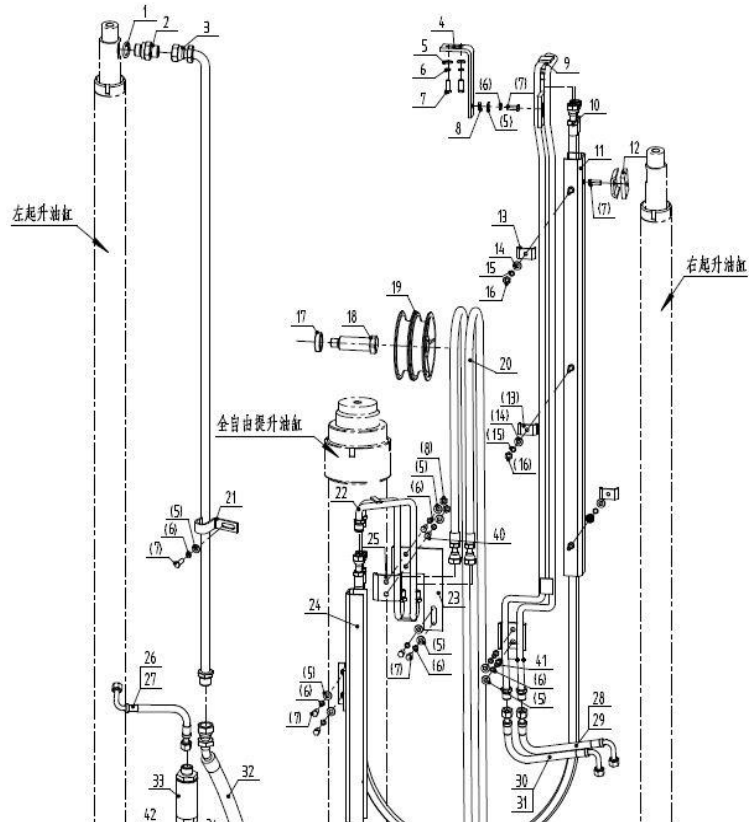

起升高度 LIFTING HEIGHT	Part-9		Part-10	备注 REMARK
	ID.	15387S-01000 Guide slot hose I	ID.	
2000	69015761	15387S-01000/1	69012989	
2500	69017034	20387S-02000/2	69012991	
2700	69012971	30387S-03000/3	69012993	
3000	69017037	20387S-02000/5	69012994	
3300	69015768	15387S-01000/8	69012995	
3500	69012976	30387S-03000/8	69012997	
3700	69012977	30387S-03000/9	69013000	
4000	69017119	35387S-03000/13	69013002	
4500	69017038	20387S-02000/15	69016785	
5000	69017040	20387S-02000/17	69013006	
5500	69015779	15387S-01000/19	69013007	
6000	69015780	15387S-01020	69016793	







图71/Fig. 71

门架管路系统(两级全自由三联)/MAST HYDRAULIC SYSTEM(FULL FREE 2-STAGE MAST THREE-THROW)

FBA20/25/30/35-JZ

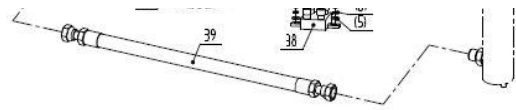
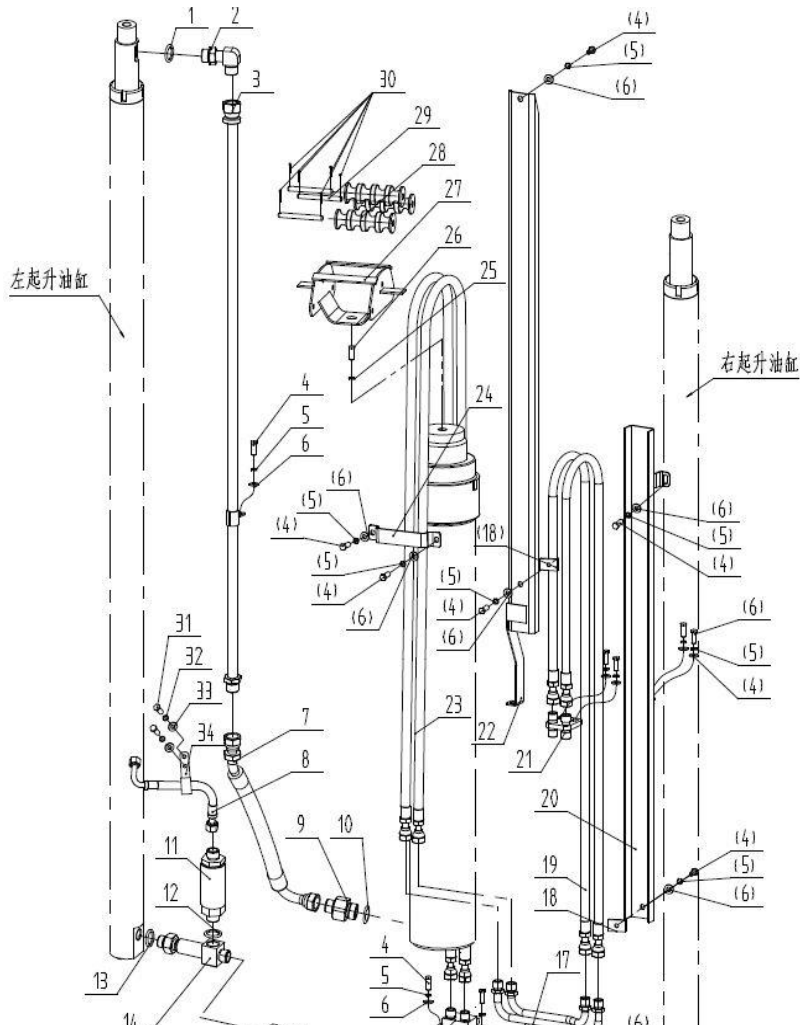

序号	物料号	代号	名称	数量	备注
Item No.	ID.	Part No.	Description	Q'ty	Remark
A	N/A		Mast hydraulic system	1	FBA20/25/30/35-JZ
1	69124144	GB/T3452.1-19*2.65-G	O-ring 19×2.65	1	
2	69003137	M3077601000	Pipe connector	1	
3	N/A	A20487-01000	Pipe ass'y	1	FBA20/25-JZ
-	N/A	A30487-02000	Pipe ass'y	1	FBA30-JZ
-	N/A	A35487-01000	Pipe ass'y	1	FBA35-JZ
4	69000309	GB/T5783-M8*16-8.8J	Bolt M8×16	14	
5	69000259	GB/T97.1-8	washer 8	14	
6	69000062	GB/T93-8	Washer 8	14	
7	69015804	15387-00001	Middle cylinder H.P. hose	1	FBA20/25/30-JZ
-	69016686	30387-00001	Middle cylinder H.P. hose	1	FBA35-JZ
8	69022704	45776-00008	Flow regulator H.P. hose II	1	
9	69012037	30387-00003	Middle cylinder connector	1	取消, 厂家自带
10	69124132	GB1235-30*3.5-G	O-ring 30×3.5	1	
11	69002920	20386-01000	Speed limiting valve	1	FBA20/25-JZ
-	69002922	30386-03000	Speed limiting valve	1	FBA30-JZ
-	69002923	35386-02000	Speed limiting valve	1	FBA35-JZ
12	69022457	GB/T1235-24*2.4	O-ring 24×2.4	1	
13	69124142	GB/T3452.1-17*2.65-G	O-ring 17×2.65	1	
14	69016646	30386-01000	Lift cylinder tee connector	1	
15	69130621	A20488-00001	H.P. hose	1	FBA20/25/30-JZ

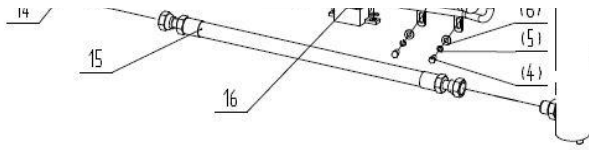

-	69121326	A30786-00001	H. P. hose	1	FBA35-JZ
16	69012712	30387S-08000	Four way II	1	
17	69034163	A30487S-04000	Connecting pipe	1	
18	69056648	30387S-07001	Plate	2	

图71/Fig. 71

门架管路系统(两级全自由三联)/MAST HYDRAULIC SYSTEM(FULL FREE 2-STAGE MAST THREE-THROW)

FBA20/25/30/35-JZ

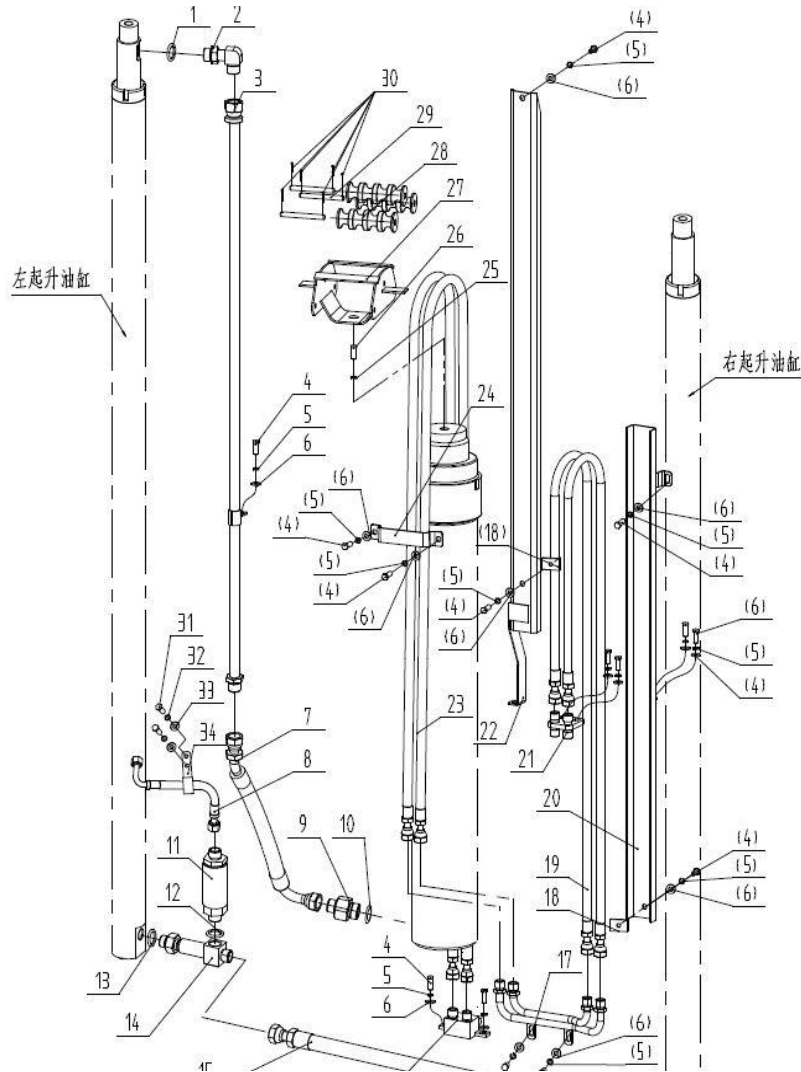

序号	物料号	代号	名称	数量	备注
Item No.	ID.	Part No.	Description	Q'ty	Remark
19	N/A	A30487S-05000	H. P. hose	2	
20	N/A	A25787S-01000	Guider ass'y(right) II	1	FBA20/25-JZ
-	N/A	A30487S-03000	Guider ass'y(right) II	1	FBA30/35-JZ
21	69034162	A30487S-01000	Four way	1	
22	N/A	A20487S-01000	Guider ass'y(right) I	1	FBA20/25-JZ
-	N/A	A30487S-02000	Guider ass'y(right) I	1	FBA30-JZ
-	N/A	A35487S-01000	Guider ass'y(right) I	1	FBA35-JZ
23	N/A	A20487S-02000	Pulley H. P. hose	2	FBA20/25-JZ
-	N/A	A30487S-06000	Pulley H. P. hose	2	FBA30-JZ
-	N/A	A35487S-02000	Pulley H. P. hose	2	FBA35-JZ
24	69042096	A30488S-00002	Pipe clamp	1	
25	69000056	GB/T93-16	Washer 16	1	
26	69000176	GB/T5783-M16*80-8.8J	Bolt M16×80	1	
27	69115099	A30488S-01000A-Black	Roller bracket	1	
28	69123554	A30488S-00001B	Pulley	3	
29	69042097	GB/T880-Φ8*120	Shaft Φ8×120	3	
30	69005787	GB/T91-2*16	Cotter pin 2×16	6	
31	69000190	GB/T5783-M6*16-8.8J	Bolt M6×16	2	
32	69000258	GB/T97.1-6	washer 6	2	
33	69000060	GB/T93-6	Washer 6	2	
34	69057149	20B88-00001	Pipe clamp	1	







图71/Fig. 71

门架管路系统(两级全自由三联)/MAST HYDRAULIC SYSTEM(FULL FREE 2-STAGE MAST THREE-THROW)

FBA20/25/30/35-JZ

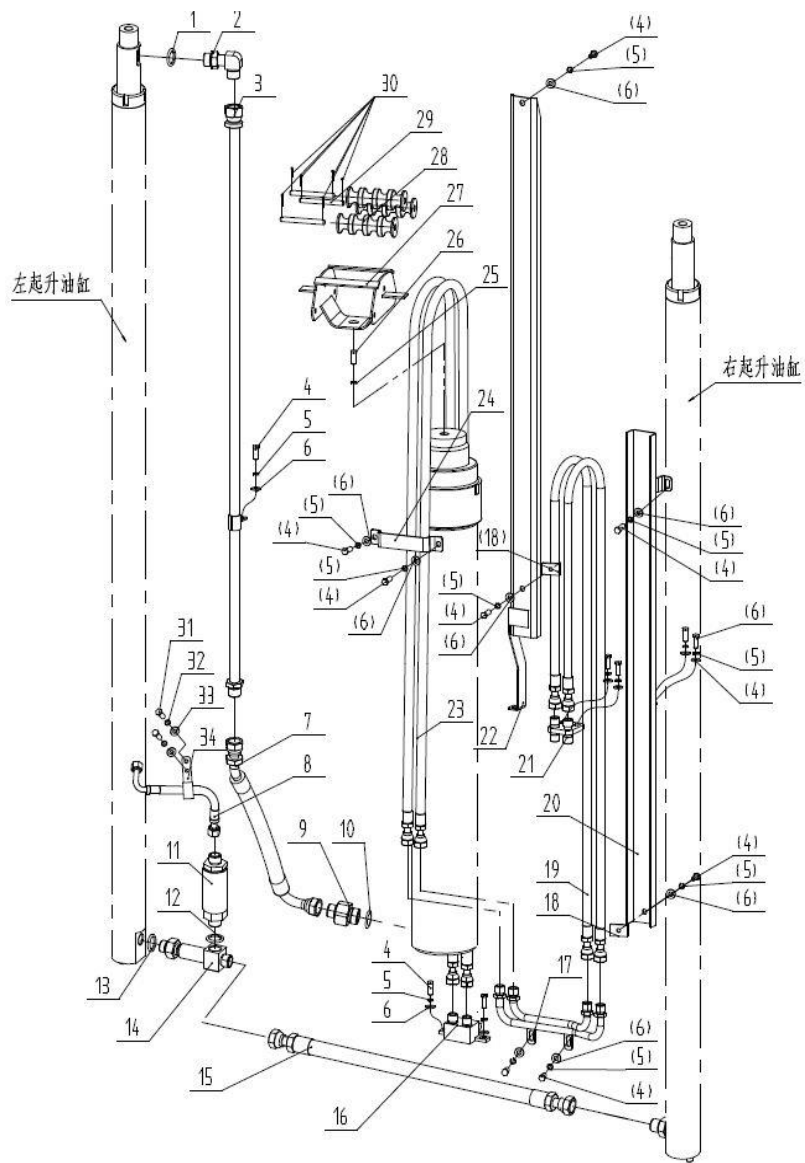

管路系统选用件 (件23)  
Mast Piping Optional Parts part-23

起升高度 LIFTING HEIGHT	2.0-2.5t		3.0t	3.5t	
	ID.	A20487S-02000 Pulley H.P.hose	ID.	ID.	A35487S-02000 Pulley H.P.hose
3000	69016819	30388SS-02005	69016819	6,9E+07	30388SS-02006
3300	69013015	30387S-02009	69043026	6,9E+07	30388S-02004
3500	69016786	30388S-02004	69017072	6,9E+07	30387S-02010
3700	69016643	20388SS-01009	69034196	6,9E+07	30387S-01018
4000	69016629	20388S-01007	69016776	6,9E+07	30388S-01004
4500	69016805	30388SS-01004	69016650	6,9E+07	20387S-01012
5000	69016651	30386S-01009	69016892	6,9E+07	20388S-01011
5500	69016780	30388S-01008	69016894	6,9E+07	35388S-01008
6000	69046328	A20488SS-02001	69016653	6,9E+07	30388S-01009

图72/Fig. 72

门架管路系统(两级全自由四联)/MAST HYDRAULIC SYSTEM(FULL FREE 2-STAGE MAST FOUR-THROW)

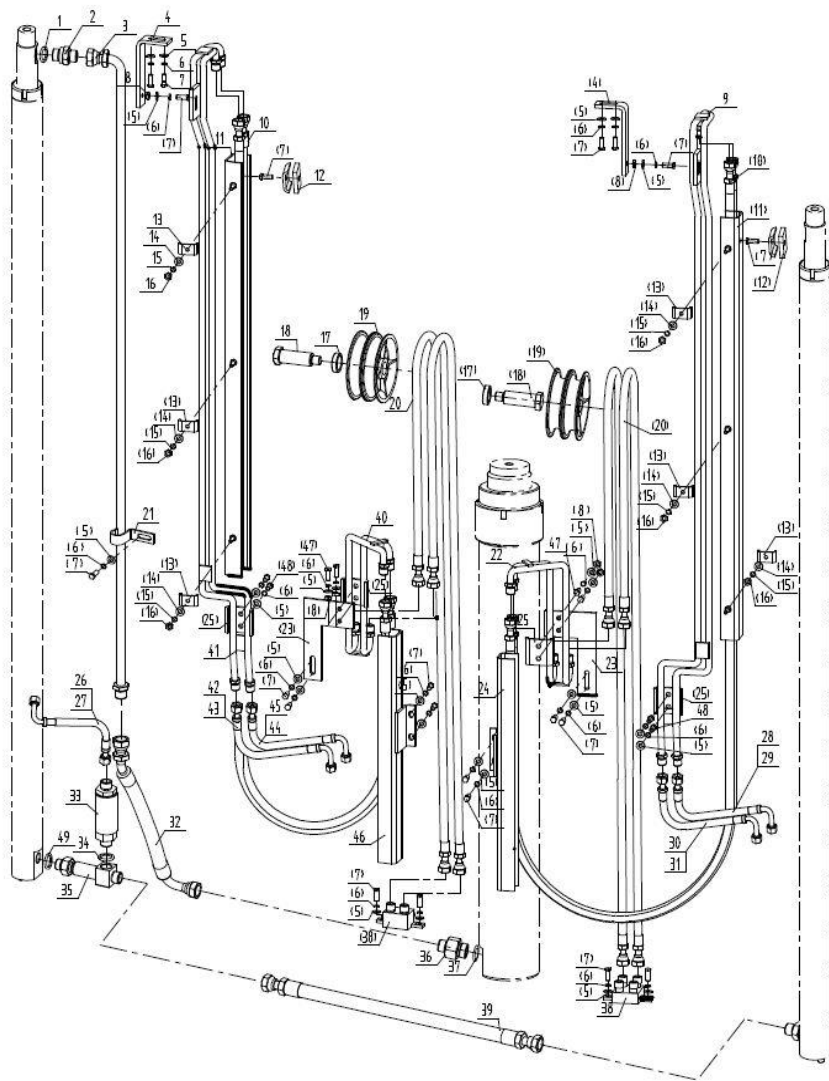

序号	物料号	代号	名称	数量	备注
Item No.	ID.	Part No.	Description	Q' ty	Remark
1	69124131	GB1235-22*2.4-G	O-ring 22×2.4	1	
2	69001443	35387-00001	Lifting cylinder connector	1	
3	N/A	20387-01000	Hose pipe assemblies	1	
4	69016706	30387S-00003	Lacating plate	2	
5	69000259	GB/T97.1-8	Washer 8	28	
6	69000062	GB/T93-8	Washer 8	28	
7	69000309	GB/T5783-M8*16-8.8J	Bolt M8×16	22	
8	69000111	GB/T6170-M8-8J	Nut M8	2	
9	N/A	15387S-01000	Guide slot hose I	1	
10	N/A	30387S-01000	Guide slot oil tube	4	
11	N/A	15387S-03000	Guide slot II	2	
12	69056648	30387S-07001	Oil tube clamp	2	
-	69056702	30387S-07002	Oil tube clamp	2	
13	69016708	30387S-00004	Hose clamp II	6	
14	69000258	GB/T97.1-6	Washer 6	6	
15	69000060	GB/T93-6	Washer 6	6	
16	69000111	GB/T6170-M6-8J	Nut M6	6	
17	69000579	30386S-00004(8)	Sleeve	6	
18	69016660	30386S-00003	Step bolt	2	
19	69016659	30386S-00002	Pulley	4	
20	N/A	20387S-01000	Full free cylinder inlet oil hose	4	
21	69016689	30387-00004	Hose clamp	1	
22	69015802	15387S-04000	Side shift four way I	1	

图72/Fig. 72

门架管路系统(两级全自由四联)/MAST HYDRAULIC SYSTEM(FULL FREE 2-STAGE MAST FOUR-THROW)

序号	物料号	代号	名称	数量	备注
Item No.	ID.	Part No.	Description	Q' ty	Remark
23	69016705	30387S-00002	Four way fix plate	2	

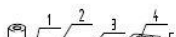



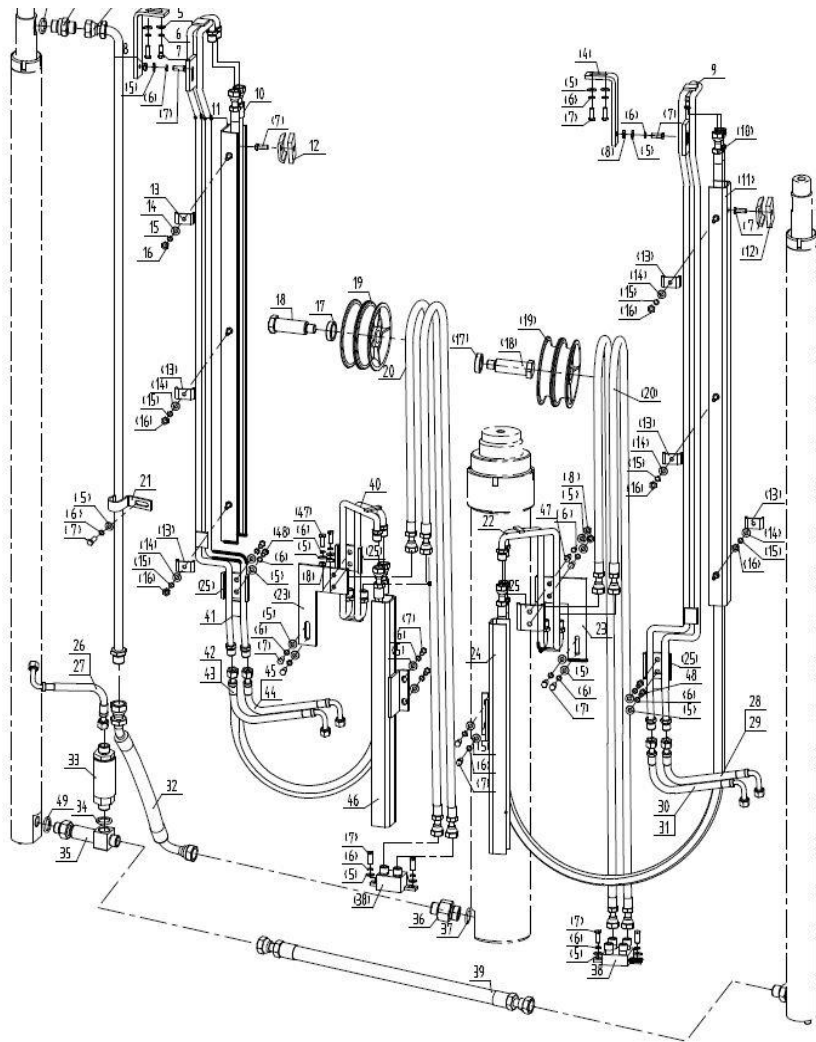

24	69046620	15387S-02000	Guide slot I	1	
25	69016703	30387S-00001	Pressure pinch	2	
26	69011950	20388-00001	Valve-Speed limiting valve hose II	1	
27	69005630	20386-00001	Valve-Speed limiting valve hose II	1	
@	69022704	45776-00008	Steer three-way connect hose	1	
28	69018460	20386SS-00001	Valve-Steering hose I	1	
29	69016667	30386S-00007	Valve-Steering hose III	1	
30	69016666	30386S-00006	Valve-Steering hose II	1	
31	69016668	30386S-00008	Valve-Steering hose IV	1	
32	69015804	15387-00001	Hard hose-Full free cylinder inlet oil hose	1	
33	69002918	15386-01000	Speed limiting valve	1	
34	69022457	GB/T1235-24*2.4	O-ring 24×2.4	1	
35	69016646	30386-01000	Lifting cylinder Three way	1	
36	69012037	30387-00003	Free cylinder connector	1	取消, 厂家自带
37	69124132	GB1235-30*3.5-G	O-ring 30×3.5	1	
38	69012712	30387S-08000	Four way II	2	
39	69020534	15386-00001	Lifting cylinder hose	1	
40	69042640	15387SS-02000	Side shift four way II	1	
41	N/A	15387SS-01000	Guide slot hose II	1	
42	69016683	30386SS-00003	Valve-Steering hose III	1	
43	69016682	30386SS-00002	Valve-Steering hose II	1	
44	69016795	30386SS-00004	Valve-Steering hose I	1	

图72/Fig. 72

门架管路系统(两级全自由四联)/MAST HYDRAULIC SYSTEM(FULL FREE 2-STAGE MAST FOUR-THROW)

FBA15/18-JZ



序号	物料号	代号	名称	数量	备注
Item No.	ID.	Part No.	Description	Q'ty	Remark
45	69016680	30386SS-00001	Valve-Steering hose I	1	
46	69021862	15387SS-03000	Guide slot I	1	
47	69000206	GB/T5783-M8*40-8.8J	Bolt M8×40	4	
48	69000218	GB/T5783-M8*60-8.8J	Bolt M8×60	4	

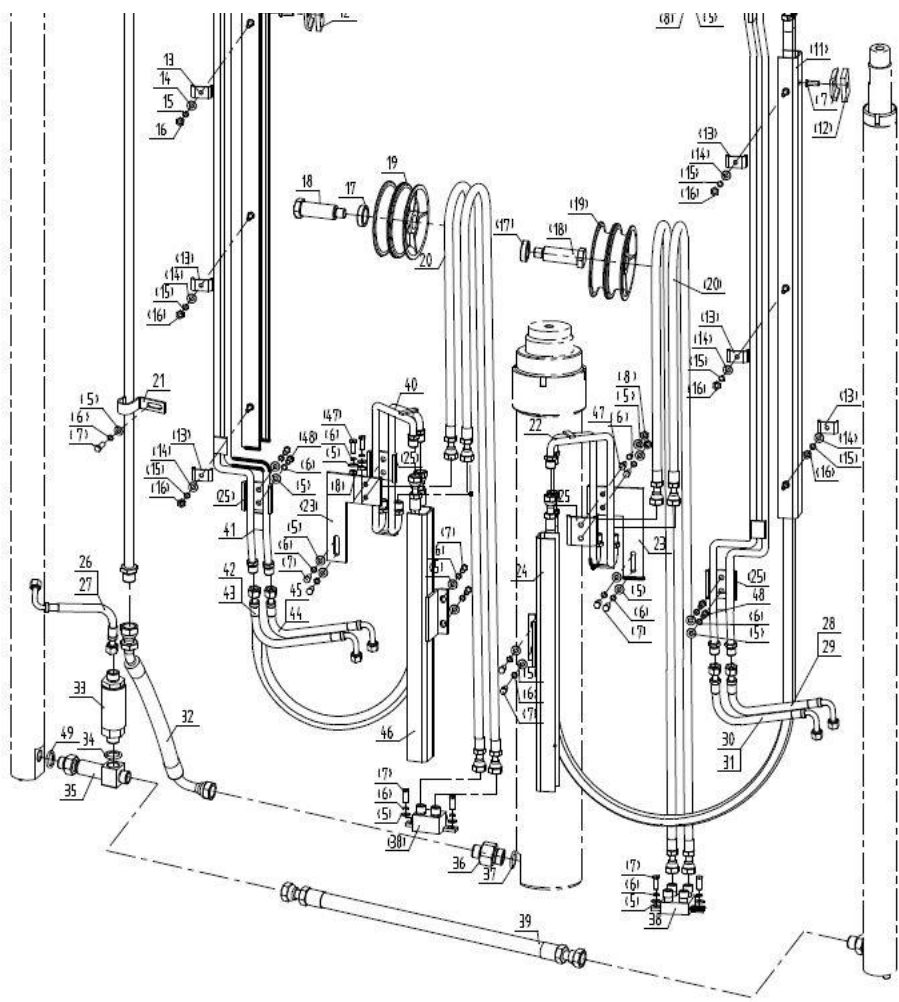

49	69124142	GB/T3452.1-17*2.65-G	O-ring 17×2.65	1	

图72/Fig. 72 门架管路系统(两级全自由四联)/MAST HYDRAULIC SYSTEM(FULL FREE 2-STAGE MAST FOUR-THROW)

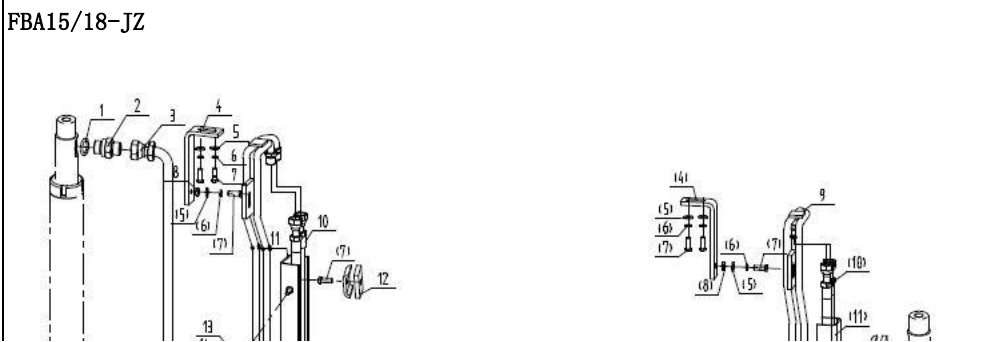

管路系统选用件 (件41) Mast Piping Optional Parts part-41				
起升高度 LIFTING G	ID.	15387SS-01000 Guide slot hose II		备注 REMARK
2000	69021857	15387SS-01001		
2500	69017056	20387SS-01000/2		
2700	69016092	30387SS-01000/3		

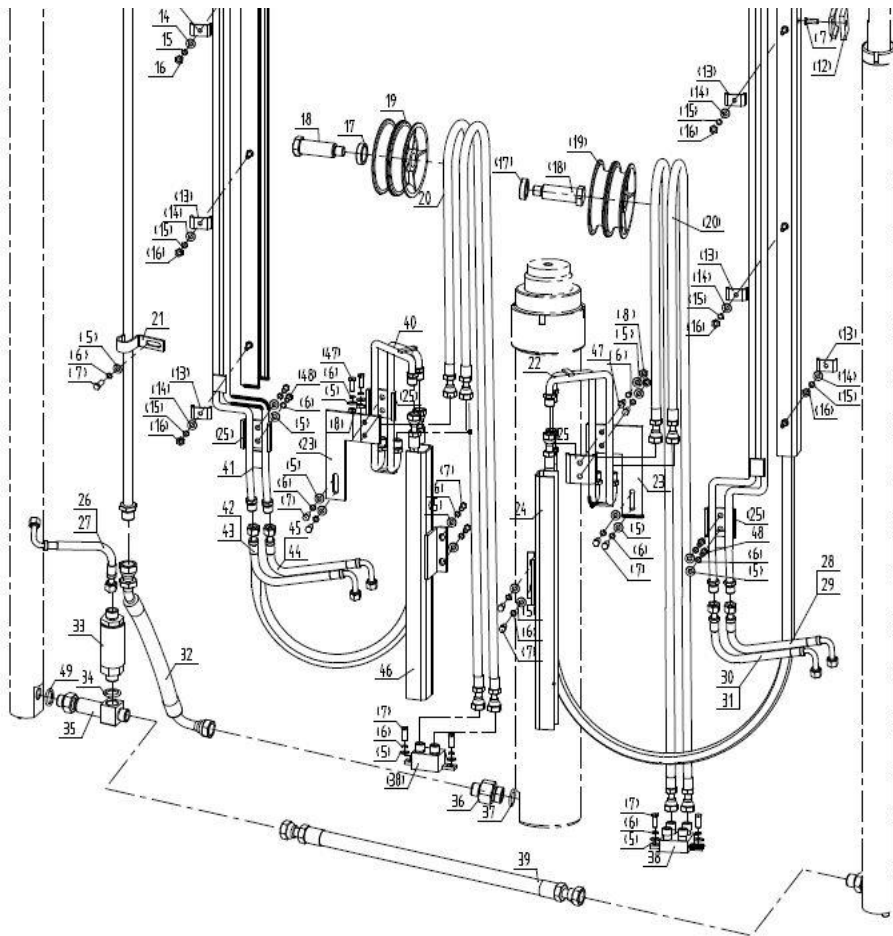

3000	69017059	20387SS-01000/5		
3300	69043097	15387SS-01000/8		
3500	69016097	30387SS-01000/8		
3700	69016098	30387SS-01000/9		
4000	69017146	35387SS-01000/13		
4500	69017060	20387SS-01000/15		
5000	69017062	20387SS-01000/17		
5500	69021860	15387SS-01000/19		
6000	69021861	15387SS-01000/20		

图73/Fig. 73

门架管路系统(两级全自由四联)/MAST HYDRAULIC SYSTEM(FULL FREE 2-STAGE MAST FOUR-THROW)

FBA20/25/30/35-JZ

序号	物料号	代号	名称	数量	备注
Item No.	ID.	Part No.	Description	Q'ty	Remark
A	N/A		Mast hydraulic system	1	FBA20/25/30/35-JZ
1	69124144	GB/T3452.1-19*2.65-G	O-ring 19×2.65	1	
2	69003137	M3077601000	Pipe connector	1	
3	N/A	A20487-01000	Pipe ass'y	1	FBA20/25-JZ
-	N/A	A30487-02000	Pipe ass'y	1	FBA30-JZ
-	N/A	A35487-01000	Pipe ass'y	1	FBA35-JZ

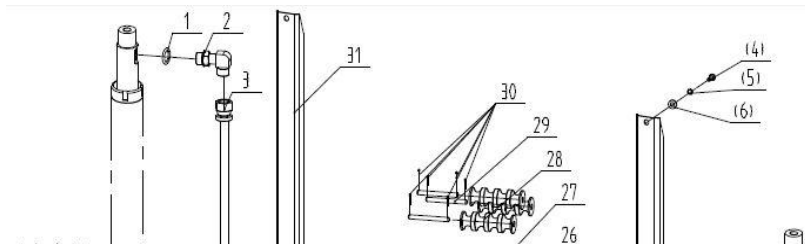

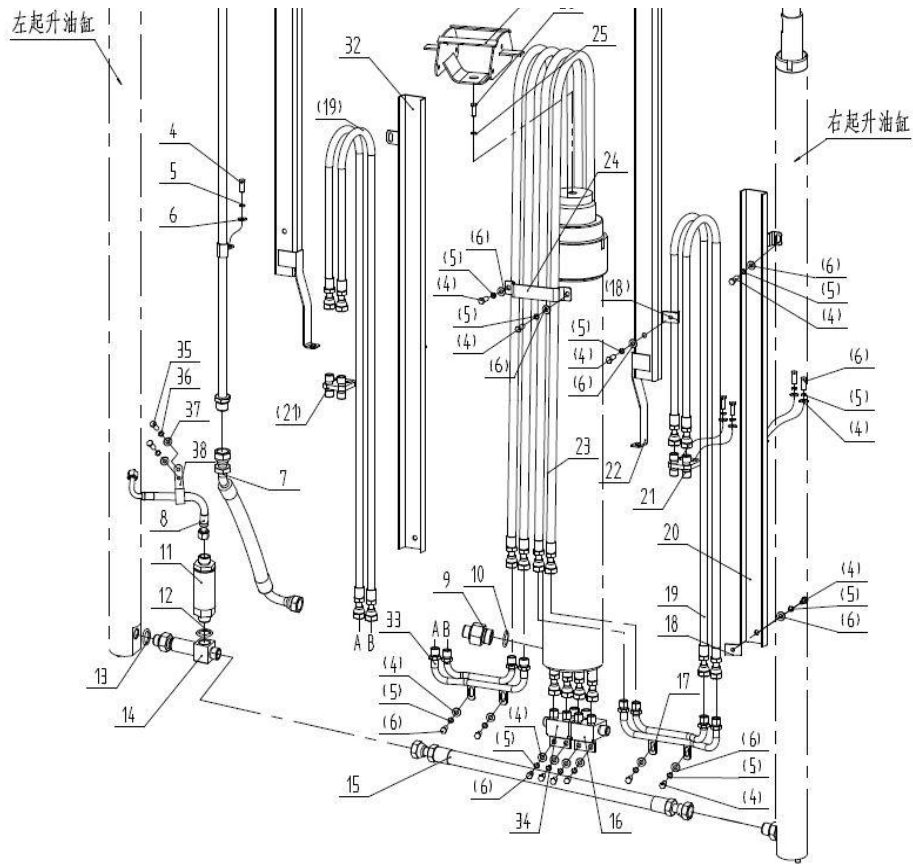

4	69000309	GB/T5783-M8*16-8.8J	Bolt M8×16	14	
5	69000259	GB/T97.1-8	washer 8	14	
6	69000062	GB/T93-8	Washer 8	14	
7	69015804	15387-00001	Middle cylinder H.P. hose	1	FBA20/25/30-JZ
-	69016686	30387-00001	Middle cylinder H.P. hose	1	FBA35-JZ
8	69022704	45776-00008	Flow regulator H.P. hose II	1	
9	69012037	30387-00003	Middle cylinder connector	1	取消, 厂家自带
10	69124132	GB1235-30*3.5-G	O-ring 30×3.5	1	
11	69002920	20386-01000	Speed limiting valve	1	FBA20/25-JZ
-	69002922	30386-03000	Speed limiting valve	1	FBA30-JZ
-	69002923	35386-02000	Speed limiting valve	1	FBA35-JZ
12	69022457	GB/T1235-24*2.4	O-ring 24×2.4	1	
13	69124142	GB/T3452.1-17*2.65-G	O-ring17×2.65	1	
14	69016646	30386-01000	Lift cylinder tee connector	1	
15	69130621	A20488-00001	H.P. hose	1	FBA20/25/30-JZ
-	69121326	A30786-00001	H.P. hose	1	FBA35-JZ
16	69034198	A30488S-04000	Four way I	1	
17	69056273	A20487SS-03000	Connecting pipe	1	
18	69056648	30387S-07001	Plate	4	
19	N/A	A30487S-05000	H.P. hose	4	

图73/Fig. 73

门架管路系统(两级全自由四联)/MAST HYDRAULIC SYSTEM(FULL FREE 2-STAGE MAST FOUR-THROW)

FBA20/25/30/35-JZ

序号	物料号	代号	名称	数量	备注
Item No.	ID.	Part No.	Description	Q'ty	Remark
20	N/A	A25787S-03000	Guider ass'y(right) II	1	FBA20/25-JZ
-	N/A	A30487S-03000	Guider ass'y(right) II	1	FBA30/35-JZ
21	69034162	A30487S-01000	Four way	2	
22	N/A	A20487S-01000	Guider ass'y(right) I	1	FBA20/25-JZ
-	N/A	A30487S-02000	Guider ass'y(right) I	1	FBA30-JZ
-	N/A	A35487S-01000	Guider ass'y(right) I	1	FBA35-JZ

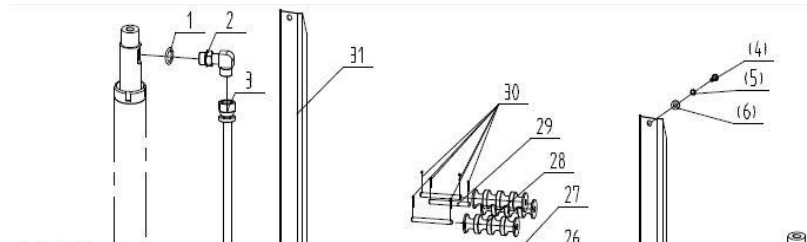





图73/Fig. 73

门架管路系统(两级全自由四联)/MAST HYDRAULIC SYSTEM(FULL FREE 2-STAGE MAST FOUR-THROW)

FBA20/25/30/35-JZ

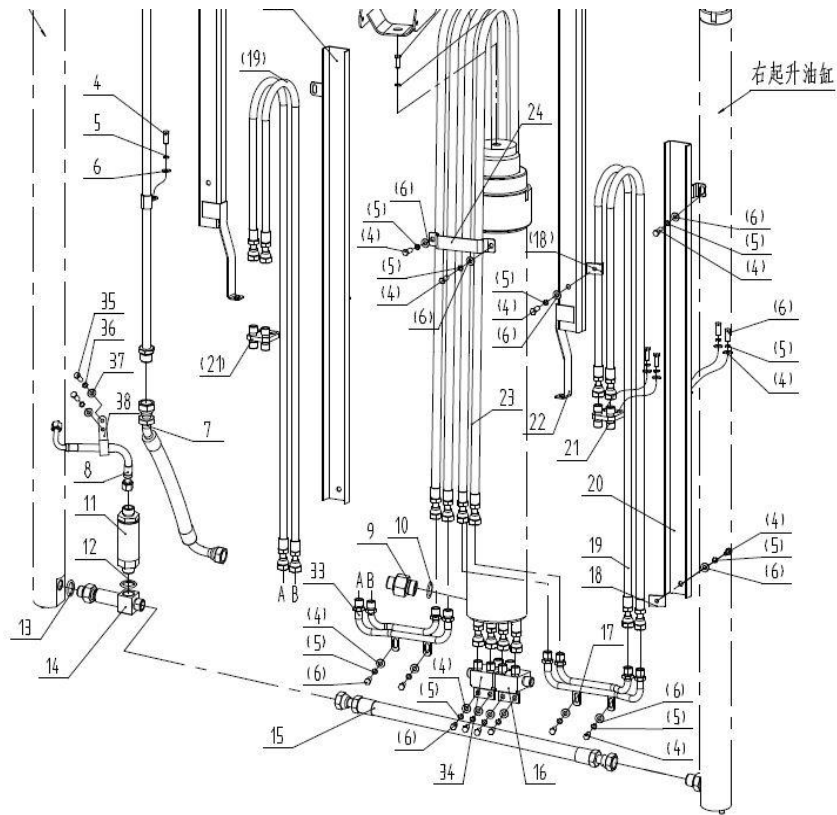
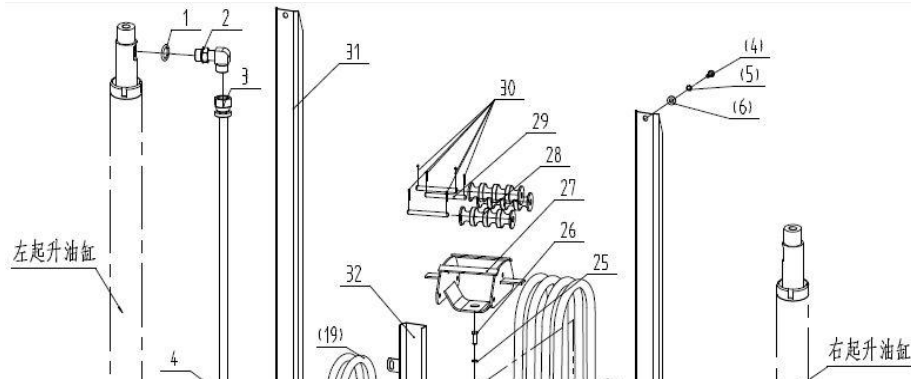

管路系统选用件 (件31)  
Mast Piping Optional Parts part-31

起升高度 LIFTING HEIGHT	2.0-2.5t		3.0t	3.5t	
	ID.	A20487SS-01000 Guider ass'y(left) I	ID.	ID.	A35487SS-01000 Guider ass'y(left) I
3000	69056264	A20487SS-01000/1	69044925	6, 9E+07	A35487SS-01000/1
3300	69056265	A20487SS-01000/2	69044926	6, 9E+07	A35487SS-01000/2
3500	69056266	A20487SS-01000/3	69044927	6, 9E+07	A35487SS-01000/3
3700	69056267	A20487SS-01000/4	69044928	6, 9E+07	A35487SS-01000/4
4000	69056268	A20487SS-01000/5	69044929	6, 9E+07	A35487SS-01000/5
4500	69056269	A20487SS-01000/6	69044930	6, 9E+07	A35487SS-01000/6

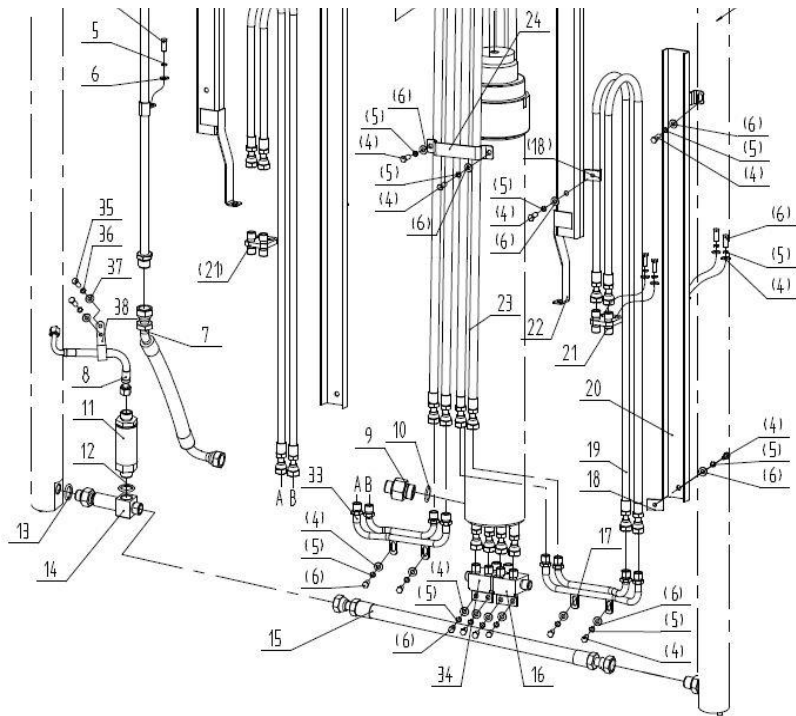

5000	69056270	A20487SS-01000/7	69044931	6, 9E+07	A35487SS-01000/7
5500	69056271	A20487SS-01000/8	69044932	6, 9E+07	A35487SS-01000/8
6000	69056272	A20487SS-01000/9	69044933	6, 9E+07	A35487SS-01000/9

图73/Fig. 73 门架管路系统(两级全自由四联)/MAST HYDRAULIC SYSTEM(FULL FREE 2-STAGE MAST FOUR-THROW)

FBA20/25/30/35-JZ

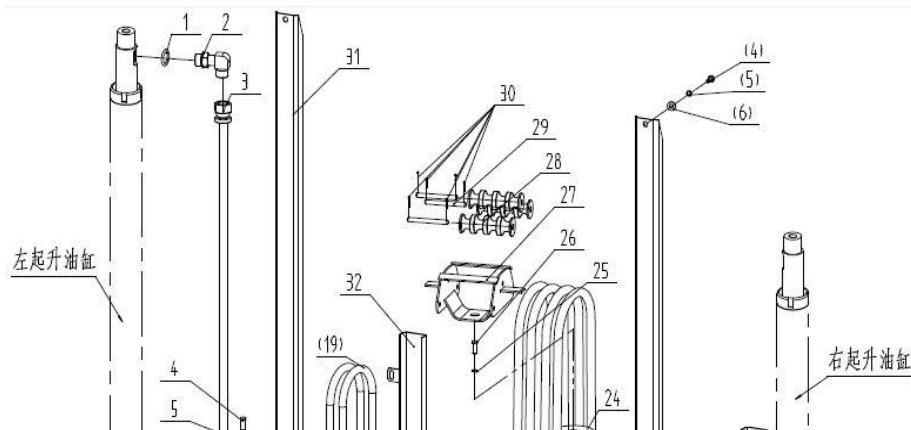

管路系统选用件 (件32)  
Mast Piping Optional Parts part-32

起升高度 LIFTING HEIGHT	2.0-2.5t		3.0-3.5t	备注 REMARK
	ID.	A25787SS-01000 Guider ass'y(left) II	ID.	
3000	69084256	A25787SS-01000/1	69044916	
3300	69084257	A25787SS-01000/2	69044917	
3500	69084258	A25787SS-01000/3	69044918	
3700	69084259	A25787SS-01000/4	69044919	
4000	69084260	A25787SS-01000/5	69044920	
4500	69084261	A25787SS-01000/6	69044921	
5000	69084262	A25787SS-01000/7	69044922	

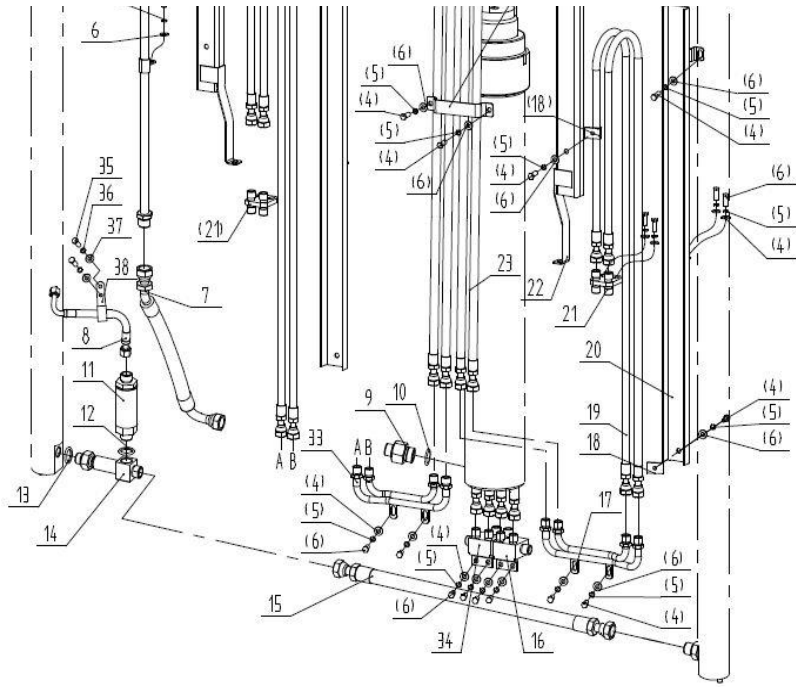

5500	69084263	A25787SS-01000/8	69044923	
6000	69084264	A25787SS-01000/9	69044924	

图74/Fig. 74

门架管路系统(三级全自由二联)/MAST HYDRAULIC SYSTEM(FULL FREE 3-STAGE MAST TWO-THROW)

FBA15/18-JZ

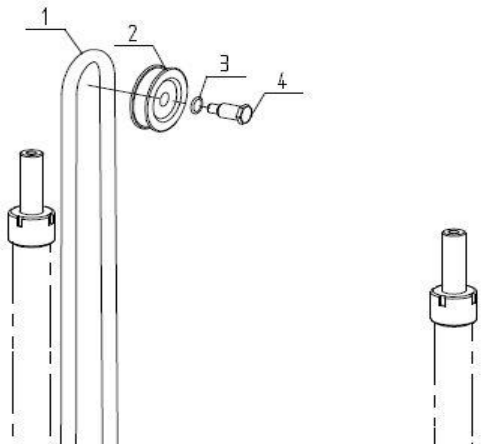

序号	物料号	代号	名称	数量	备注
Item No.	ID.	Part No.	Description	Q'ty	Remark
A	N/A		Mast hydraulic system	1	
1	N/A	30388-01000	Full free cylinder inlet oil hose	1	
2	69012027	30388SS-00002	Single pulley	1	
3	69000579	30386S-00004 (8)	Sleeve	3	
4	69016768	30388-00004	Step bolt	1	
5	69011780	15388-01000	Speed limiting valve three way	1	
6	69000259	GB/T97.1-8	Washer 8	3	
7	69000062	GB/T93-8	Washer 8	3	
8	69000309	GB/T5783-M8*16-8.8J	Bolt M8×16	3	
9	69022457	GB/T1235-24*2.4	O-ring 24×2.4	2	



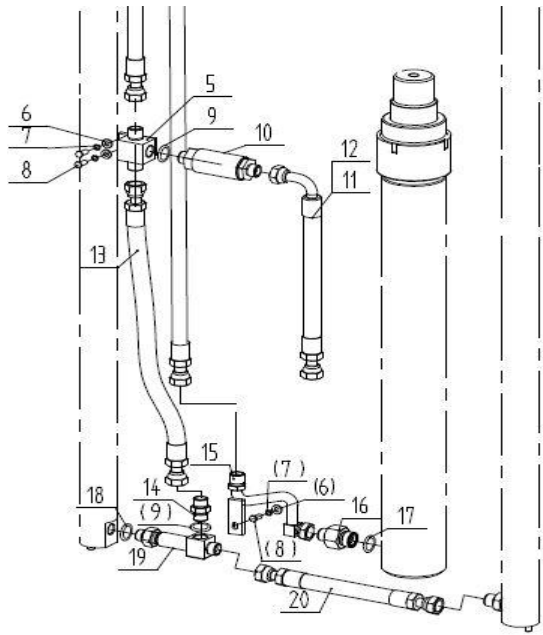

10	69002918	15386-01000	Speed limiting valve	1	
11	69011951	15388-00001	Valve-Speed limiting valve hose I	1	
12	69070284	15388-00003	Valve-Speed limiting valve hose	1	
13	69008817	15388-00002	Three way-three-way connect hose	1	
14	69016767	30388-00003	Three way-three-way connector	1	
15	69011783	15388-02000	Free cylinder inlet oil hose	1	
16	69006260	30388-00005	Free cylinder connector	1	取消, 厂家自带
17	69124132	GB1235-30*3.5-G	O-ring 30×3.5	1	
18	69124142	GB/T3452.1-17*2.65-G	O-ring 17×2.65	1	
19	69016646	30386-01000	Lifting cylinder Three way	1	
20	69020534	15386-00001	Lifting cylinder hose	1	

图74/Fig. 74

门架管路系统(三级全自由二联)/MAST HYDRAULIC SYSTEM(FULL FREE 3-STAGE MAST TWO-THROW)

FBA15/18-JZ

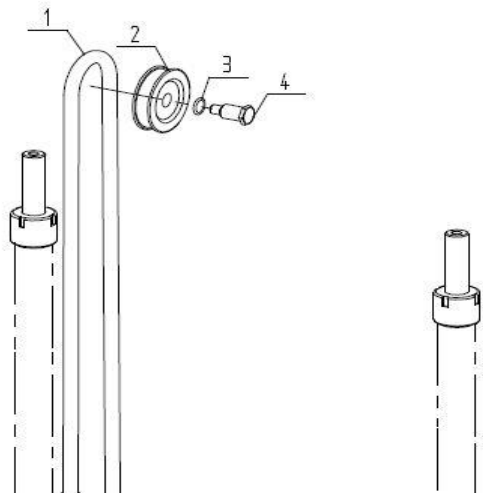

管路系统选用件 (件1) Mast Piping Optional Parts part-1				
起升高度 LIFTING G	ID.	30388-01000 Full free cylinder inlet oil hose		备注 REMARK
3600	69016752	30388-01001		
4000	69016753	30388-01002		
4350	69016754	30388-01003		
4500	69016755	30388-01004		
4800	69016756	30388-01005		
5000	69016757	30388-01006		
5400	69016758	30388-01007		
5500	69016759	30388-01008		
6000	69016760	30388-01009		

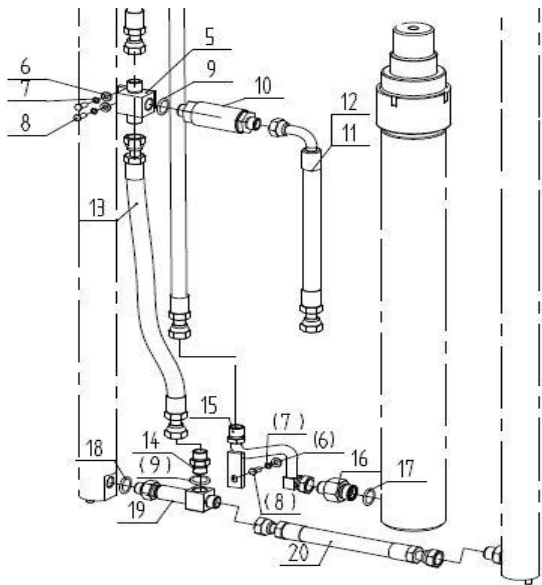

6500	69016761	30388-01010		
7000	69016762	30388-01011		
7500	69016763	30388-01012		

图75/Fig. 75 门架管路系统(三级全自由二联)/MAST HYDRAULIC SYSTEM(FULL FREE 3-STAGE MAST TWO-THROW)

FBA20/25/30/35-JZ

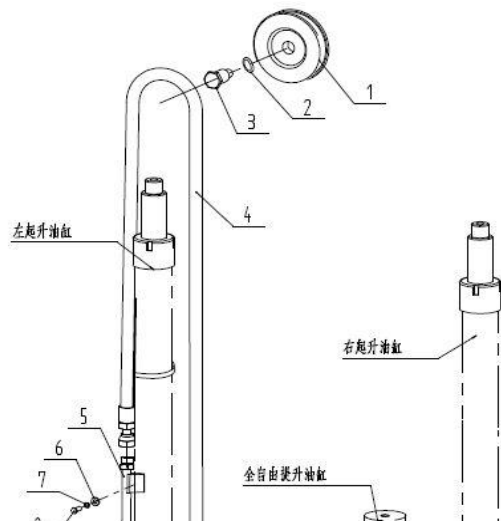

序号 Item No.	物料号 ID.	代号 Part No.	名称 Description	数量 Q'ty	备注 Remart
1	69004304	30388-00002	Three stage pulley	1	
2	69000579	30386S-00004(8)	Sleeve	2	
3	69016768	30388-00004	Step bolt	1	
4	N/A	A20488-01000	Full free cylinder inlet oil hose	1	FBA20/25/30-JZ
-	N/A	A35788-01000	Full free cylinder inlet oil hose	1	FBA35-JZ
5	69071446	A25788-01000	Transfer hose	1	FBA20/25-JZ
-	69077340	A30788-01000	Transfer hose	1	FBA30/35-JZ
6	69000259	GB/T97.1-8	Washer 8	4	
7	69000062	GB/T93-8	Washer 8	4	
8	69000309	GB/T5783-M8*16-8.8J	Bolt M8×16	4	
9	69016770	30388-02000	Speed limiting valve three way	1	
10	69022457	GB/T1235-24*2.4	O-ring 24x2.4	2	





图75/Fig. 75

门架管路系统(三级全自由两联)/MAST HYDRAULIC SYSTEM(FULL FREE 3-STAGE MAST TWO-THROW)

FBA20/25/30/35-JZ

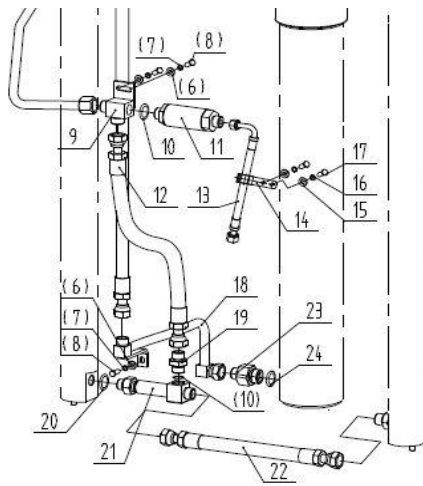
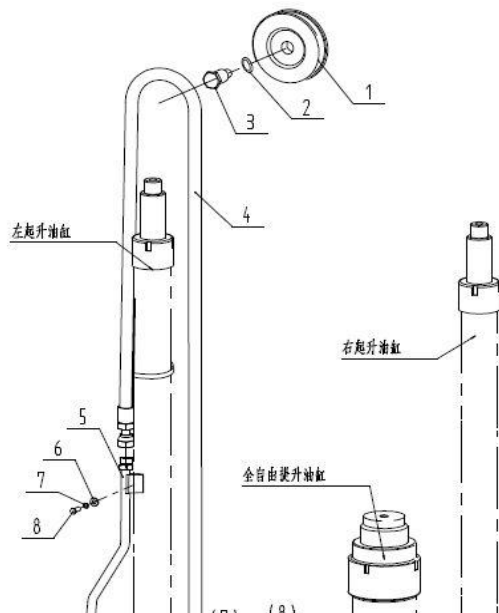

管路系统选用件 (件4)  
Mast Piping Optional Parts part-4

起升高度 LIFTING HEIGHT	2.0-2.5t		3.0-3.5t	备注 REMARK
	ID.	A20488-01000 Full free cylinder inlet oil hose	ID.	
3600	69042812	A20488-01001	69016876	
4000	69042839	A20488-01002	69016877	
4350	69042840	A20488-01003	69016878	
4500	69042842	A20488-01004	69016879	
4800	69042843	A20488-01005	69016880	
5000	69042845	A20488-01006	69012942	
5400	69042846	A20488-01007	69012322	
5500	69012321	16888-01007	69084417	
6000	69042848	A20488-01008	69016884	
6500	69042849	A20488-01009	69016885	





图76/Fig. 76

门架管路系统(三级全自由三联)/MAST HYDRAULIC SYSTEM(FULL FREE 3-STAGE MAST THREE-THROW)

FBA15/18-JZ

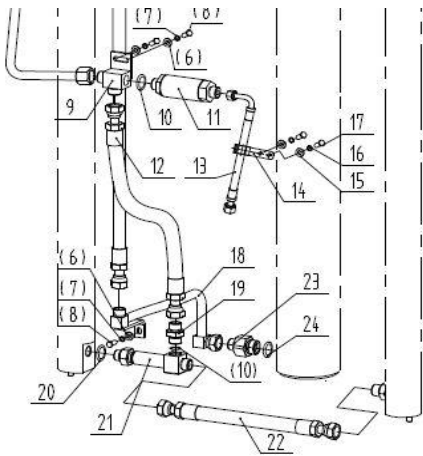
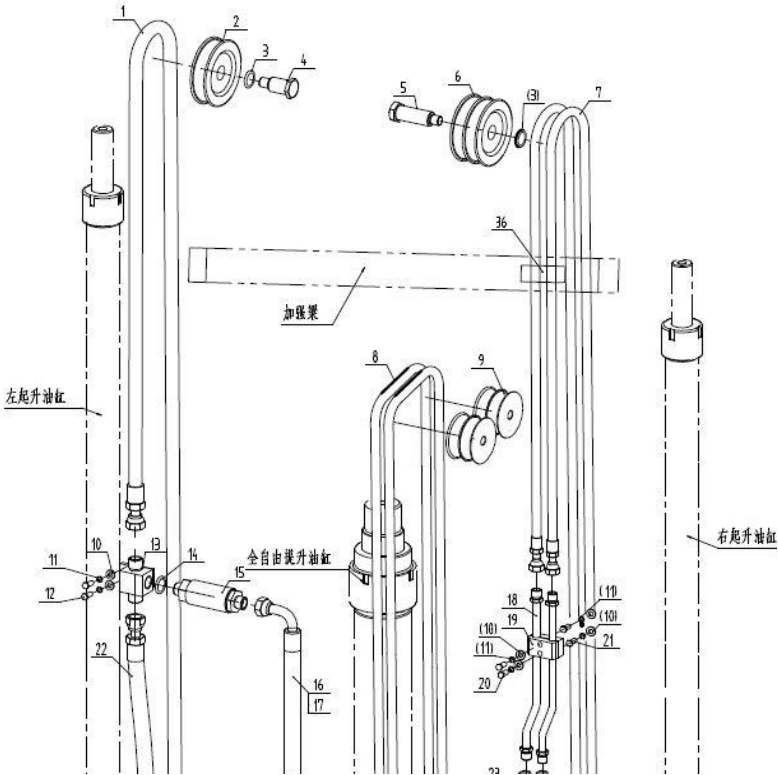

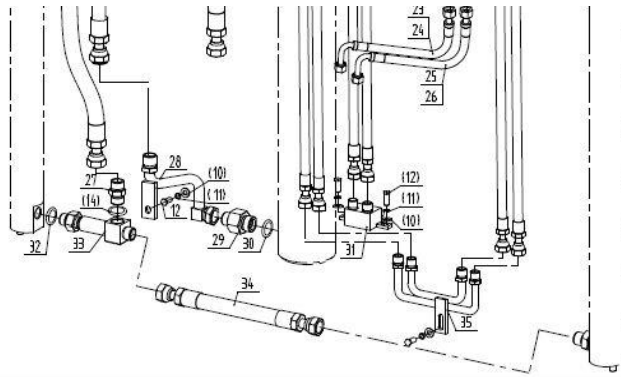
序号 Item No.	物料号 ID.	代号 Part No.	名称 Description	数量 Q'ty	备注 Remart
1	N/A	30388-01000	Full free cylinder inlet oil hose	1	
2	69012027	30388SS-00002	Single pulley	1	
3	69000579	30386S-00004 (8)	Sleeve	5	
4	69016768	30388-00004	Step bolt	1	
5	69016660	30386S-00003	Step bolt	1	
6	69004319	15388S-00001	Triple double pulley	1	
7	N/A	15388S-01000	Side shift hose I	2	
8	N/A	15388S-02000	Side shift hose II	2	
9	69000686	15388S-00002	Middle cylinder double pulley	2	
10	69000259	GB/T97.1-8	Washer 8	4	
11	69000062	GB/T93-8	Washer 8	4	
12	69000309	GB/T5783-M8*16-8.8J	Bolt M8×16	4	
13	69011780	15388-01000	Speed limiting valve three way	1	
14	69022457	GB/T1235-24*2.4	O-ring 24×2.4	2	
15	69002918	15386-01000	Speed limiting valve	1	



16	69011951	15388-00001	Valve-Speed limiting valve hose I	1	
17	69070284	15388-00003	Valve-Speed limiting valve hose	1	
18	69016675	30386S-02000	Steering hose	2	
19	69066450	30386S-00001/B	Pipe clamp upper	1	
20	69000203	GB/T5783-M8*30-8.8J	Bolt M8×30	2	
21	69000200	GB/T5783-M8*25-8.8J	Bolt M8×25	2	
22	69008817	15388-00002	Three way-three-way connect hose	1	
23	69018460	20386SS-00001	Valve-Steering hose I	1	

图76/Fig. 76

门架管路系统(三级全自由三联)/MAST HYDRAULIC SYSTEM(FULL FREE 3-STAGE MAST THREE-THROW)

FBA15/18-JZ

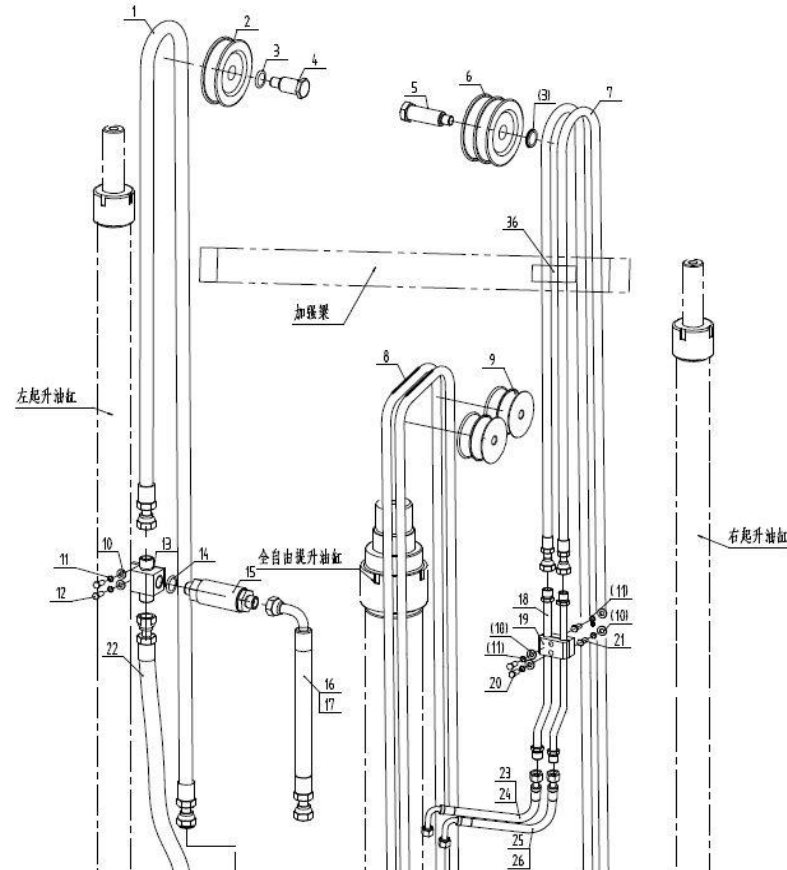

序号 Item No.	物料号 ID.	代号 Part No.	名称 Description	数量 Q'ty	备注 Remart
24	69016667	30386S-00007	Valve-Steering hoseIII	1	
25	69016666	30386S-00006	Valve-Steering hose II	1	
26	69016668	30386S-00008	Valve-Steering hoseIV	1	
27	69016767	30388-00003	Three way-three-way connector	1	
28	69011783	15388-02000	Free cylinder inlet oil hose	1	
29	69006260	30388-00005	Free cylinder connector	1	取消, 厂家自带
30	69124132	GB1235-30*3.5-G	O-ring 30×3.5	1	
31	69012712	30387S-08000	Four way II	1	
32	69124142	GB/T3452.1-17*2.65-G	O-ring 17×2.65	1	
33	69016646	30386-01000	Lifting cylinder Three way	1	
34	69020534	15386-00001	Lifting cylinder connect hose	1	
35	69001495	15388S-03000	Side shift transfer seat	1	
36	69069602	S30488S-00003	Pipe clamp	1	≥6m







图77/Fig. 77

门架管路系统(三级全自由三联)/MAST HYDRAULIC SYSTEM(FULL FREE 3-STAGE MAST THREE-THROW)

FBA20/25/30/35-JZ

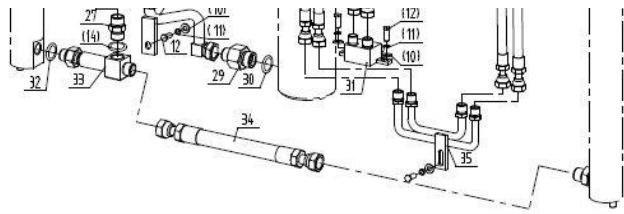
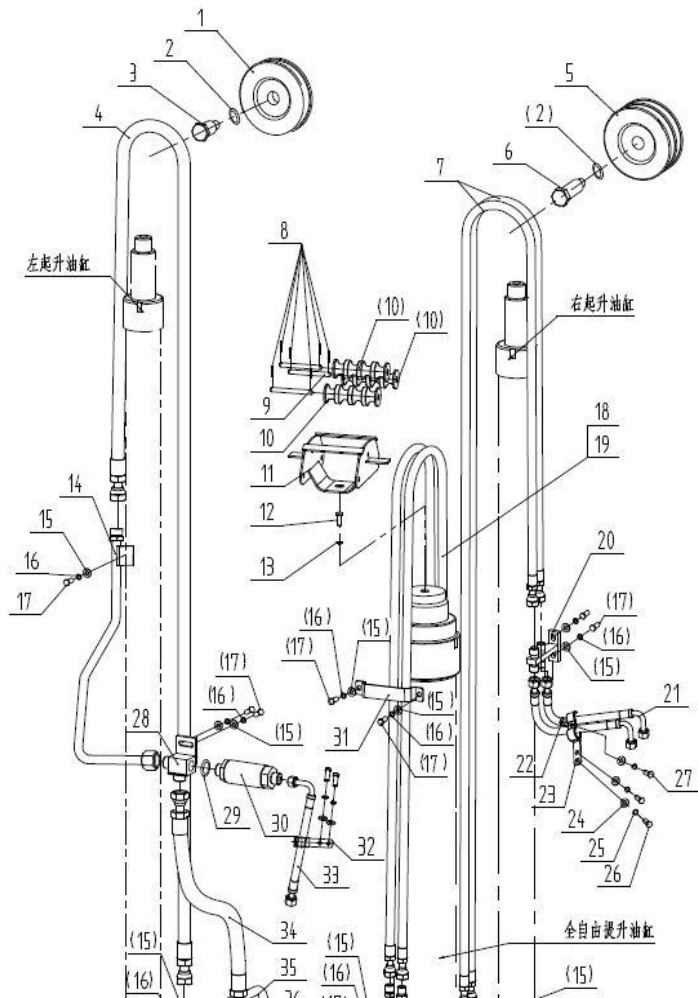

序号	物料号	代号	名称	数量	备注
Item No.	ID.	Part No.	Description	Q'ty	Remart
1	69004304	30388-00002	Three stage pulley	1	
2	69000579	30386S-00004 (8)	Sleeve	4	
3	69016768	30388-00004	Step bolt	1	
4	N/A	A20488-01000	Full free cylinder inlet oil hose	1	FBA20/25/30-JZ
-	N/A	A35788-01000	Full free cylinder inlet oil hose	1	FBA35-JZ
5	69012028	30388S-00004	Three stage double pulley	1	
6	69016660	30386S-00003	Step bolt	1	
7	N/A	A20488S-01000	Side shift hose I	2	FBA20/25/30-JZ
-	N/A	A35788S-01000	Side shift hose I	2	FBA35-JZ
8	69005787	GB/T91-2*16	Cotter pin 2×16	6	
9	69042097	GB/T880-Φ8*120	Shaft Φ8×120	3	
10	69123554	A30488S-00001B	Pulley	3	
11	69115099	A30488S-01000A-Black	Roller bracket	1	
12	69000176	GB/T5783-M16*80-8.8J	Bolt M16×80	1	
13	69000056	GB/T93-16	Washer 16	1	
14	69071446	A25788-01000	Steering hose	1	FBA20/25-JZ
-	69077340	A30788-01000	Steering hose	1	FBA30/35-JZ
15	69000259	GB/T97.1-8	Washer 8	12	
16	69000062	GB/T93-8	Washer 8	12	
17	69000309	GB/T5783-M8*16-8.8J	Bolt M8×16	12	



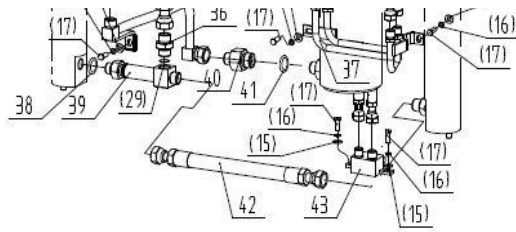

18	N/A	A25788S-01000A	Side shift hose I	2	FBA20/25-JZ
-	N/A	A30788S-01000	Side shift hose I	2	FBA30-JZ
-	N/A	A35788S-02000	Side shift hose I	2	FBA35-JZ
19	N/A	A25788S-02000A	Side shift hose II	2	FBA20/25-JZ
-	N/A	A30788S-01000	Side shift hose II	2	FBA30-JZ

图77/ Fig. 77

门架管路系统(三级全自由三联)/MAST HYDRAULIC SYSTEM(FULL FREE 3-STAGE MAST THREE-THROW)

FBA20/25/30/35-JZ

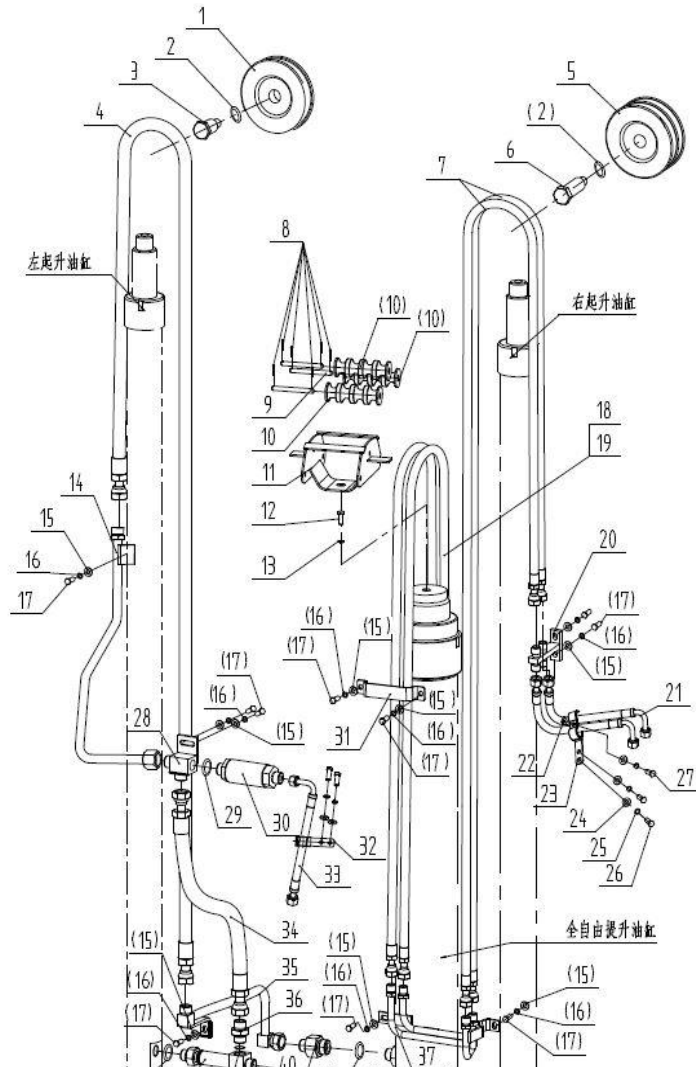

序号	物料号	代号	名称	数量	备注
Item No.	ID.	Part No.	Description	Q'ty	Remart
-	N/A	A35788S-03000	Side shift hose II	2	FBA35-JZ
20	69071447	A25788S-03000	Four way I	1	FBA20/25-JZ
-	69016799	30388S-04000	Four way I	1	FBA30/35-JZ
21	69131506	A25788S-00001	Steering cylinder oil hose I	2	
22	69000111	GB/T6170-M6-8J	Nut M6	1	
23	69057150	20B88S-00001	Pipe clamp	1	
24	69000258	GB/T97.1-6	Washer 6	5	
25	69000060	GB/T93-6	Washer 6	5	
26	69000189	GB/T5783-M6*12-8.8J	Bolt M6×12	4	
27	69000194	GB/T5783-M6*25-8.8J	Bolt M6×25	1	
28	69016770	30388-02000	Speed limiting valve three way	1	
29	69022457	GB/T1235-24*2.4	O-ring 24×2.4	2	
30	69002920	20386-01000	Speed limiting valve	1	FBA20/25-JZ
-	69002922	30386-03000	Speed limiting valve	1	FBA30/35-JZ
31	69042096	A30488S-00002	Pipe clamp	1	
32	69057149	20B88-00001	Pipe clamp	1	
33	69070284	15388-00003	Valve-Speed limiting valve hose	1	
34	69001493	30388-00001	Three way-three-way connect hose	1	
35	69071448	A25788-02000	Free cylinder inlet oil hose	1	FBA20/25-JZ
-	69034190	A30488-02000	Free cylinder inlet oil hose	1	FBA30/35-JZ
36	69016767	30388-00003	Three way-three-way connector	1	









图78/Fig. 78

## 门架管路系统(三级全自由四联)/MAST HYDRAULIC SYSTEM(FULL FREE 3-STAGE MAST FOUR-THROW)

FBA15/18-JZ

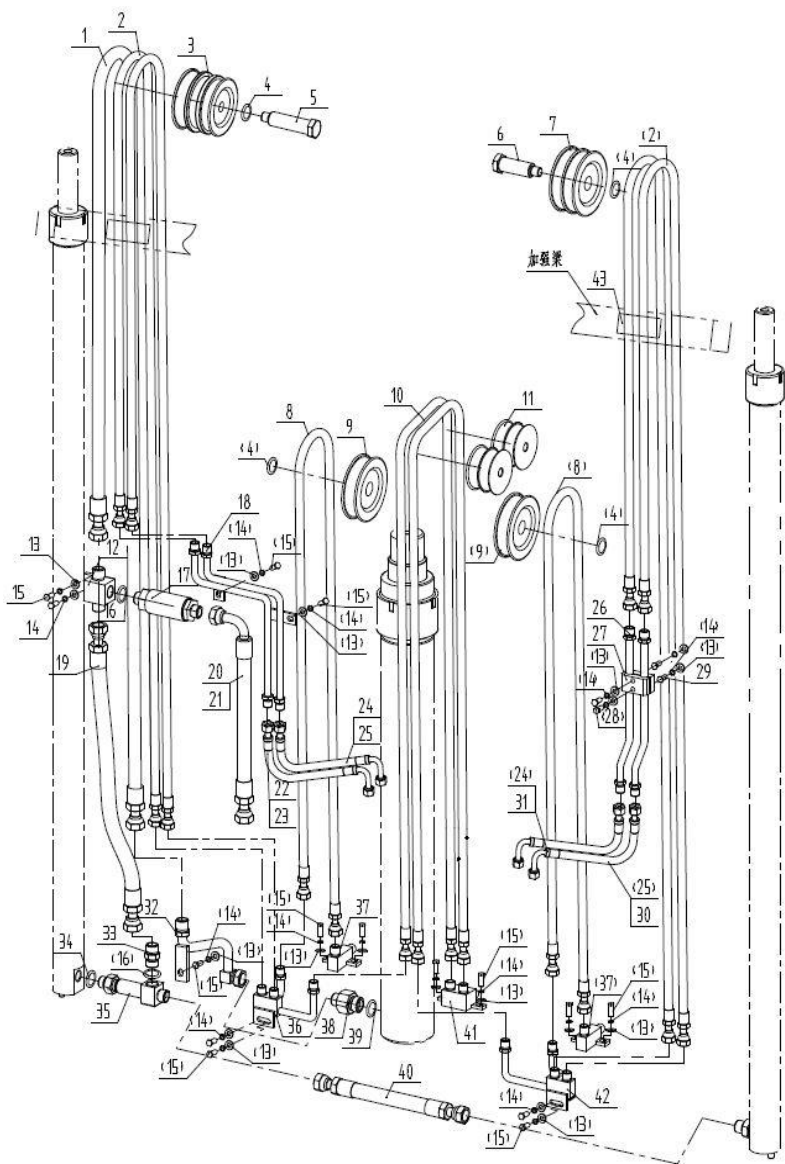

序号	物料号	代号	名称	数量	备注
Item No.	ID.	Part No.	Description	Q'ty	Remart
1	N/A	30388-01000	Full free cylinder inlet oil hose	1	
2	N/A	15388S-01000	Side shift hose I	4	
3	69010371	15388SS-00002	Pulley	1	
4	69000579	30386S-00004 (8)	Sleeve	7	
5	69020998	15388SS-00001	Step bolt	1	
6	69016660	30386S-00003	Step bolt	1	
7	69004319	15388S-00001	Triple double pulley	1	
8	N/A	15388SS-01000	Adjust hose II	2	
9	69012027	30388SS-00002	Single pulley	2	
10	N/A	15388S-02000	Side shift hose II	2	
11	69000686	15388S-00002	Middle cylinder double pulley	2	
12	69011780	15388-01000	Speed limiting valve three way	1	
13	69000259	GB/T97.1-8	Washer 8	17	
14	69000062	GB/T93-8	Washer 8	17	
15	69000190	GB/T5783-M6*16-8.8J	Bolt M6*16	13	
16	69022457	GB/T1235-24*2.4	O-ring 24x2.4	2	
17	69002918	15386-01000	Speed limiting valve	1	
18	69023907	15388SS-04000	Steering hose	1	
19	69008817	15388-00002	Three way-three way connect hose	1	
20	69011951	15388-00001	Valve-Speed limiting valve hose I	1	
21	69070284	15388-00003	Valve-Speed limiting valve hose	1	
22	69016897	35388S-00001	Valve-Steering hose	1	
23	69018461	20386SS-00002	Valve-Steering hose II	1	
24	69016668	30386S-00008	Valve-Steering hose IV	2	
25	69018460	20386SS-00001	Valve-Steering hose I	2	

图78/Fig. 78

## 门架管路系统(三级全自由四联)/MAST HYDRAULIC SYSTEM(FULL FREE 3-STAGE MAST FOUR-THROW)

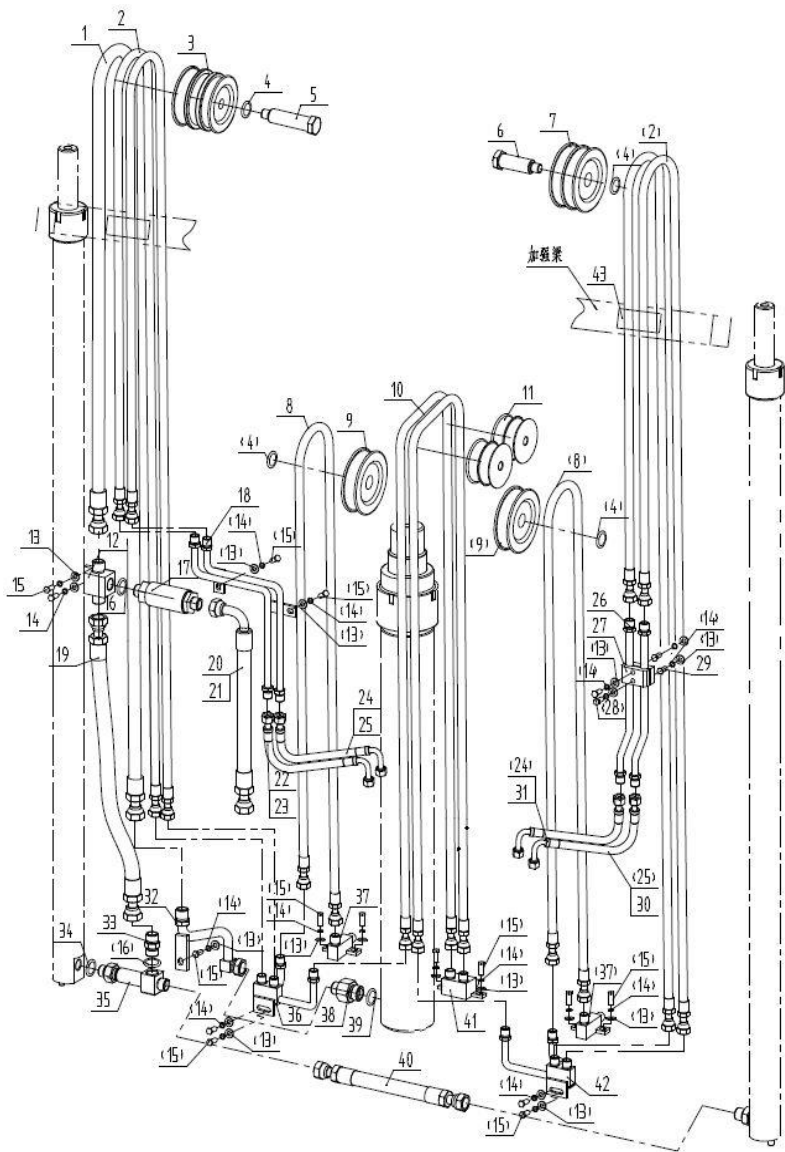

序号	物料号	代号	名称	数量	备注
Item No.	ID.	Part No.	Description	Q'ty	Remart
26	69016675	30386S-02000	Steering hose	2	
27	69066450	30386S-00001/B	Pipe clamp upper	1	
28	69000203	GB/T5783-M8*30-8.8J	Bolt M8×30	2	
29	69000200	GB/T5783-M8*25-8.8J	Bolt M8×25	2	
30	69016667	30386S-00007	Valve-Steering hoseIII	1	
31	69016666	30386S-00006	Valve-Steering hose II	1	
32	69011783	15388-02000	Free cylinder inlet oil hose	1	
33	69016767	30388-00003	Three way-three-way connector	1	
34	69124142	GB/T3452.1-17*2.65-G	O-ring 17×2.65	1	
35	69016646	30386-01000	Lifting cylinder Three way	1	
36	69011782	15388SS-02000	Steering four way I	1	
37	69016830	30388SS-07000	Quick-change two way	2	
38	69006260	30388-00005	Free cylinder connector	1	取消, 厂家自带
39	69124132	GB1235-30*3.5-G	O-ring 30×3.5	1	
40	69020534	15386-00001	Lifting cylinder connect hose	1	
41	69012712	30387S-08000	Four way II	1	
42	69011781	15388SS-03000	Steering four way II	1	
43	69069602	S30488S-00003	Pipe clamp	2	≥6m(外购)

图78/Fig. 78 门架管路系统(三级全自由四联)/MAST HYDRAULIC SYSTEM(FULL FREE 3-STAGE MAST FOUR-THROW)

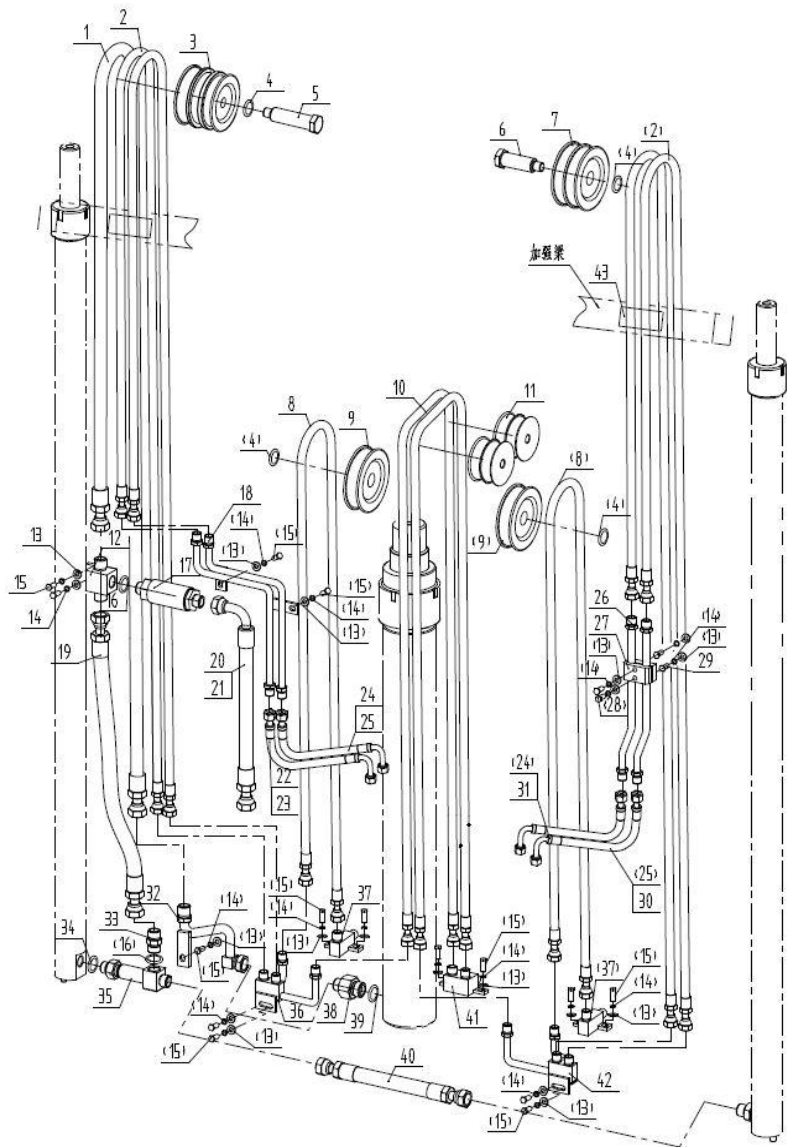

Mast Piping Optional Parts part-8

起升高度 LIFTING G	ID.	15388SS-01000 Adjust hose II		备注 REMARK
3600	69012997	30387S-01009		
4000	69013000	30387S-01012		
4350	69013014	30387S-02008		
4500	69016819	30388SS-02005		
4800	69016820	30388SS-02006		
5000	69016785	30388S-02003		
5400	69017072	30386S-01005		
5500	69016643	20388SS-01009		
6000	69016789	30388S-02006		
6500	69016776	30388S-01004		

图79/Fig. 79 门架管路系统(三级全自由四联)/MAST HYDRAULIC SYSTEM(FULL FREE 3-STAGE MAST FOUR-THROW)

FBA20/25/30/35-JZ
-------------------

序号 Item No.	物料号 ID.	代号 Part No.	名称 Description	数量 Q'ty	备注 Remart
----------------	------------	----------------	-------------------	------------	--------------



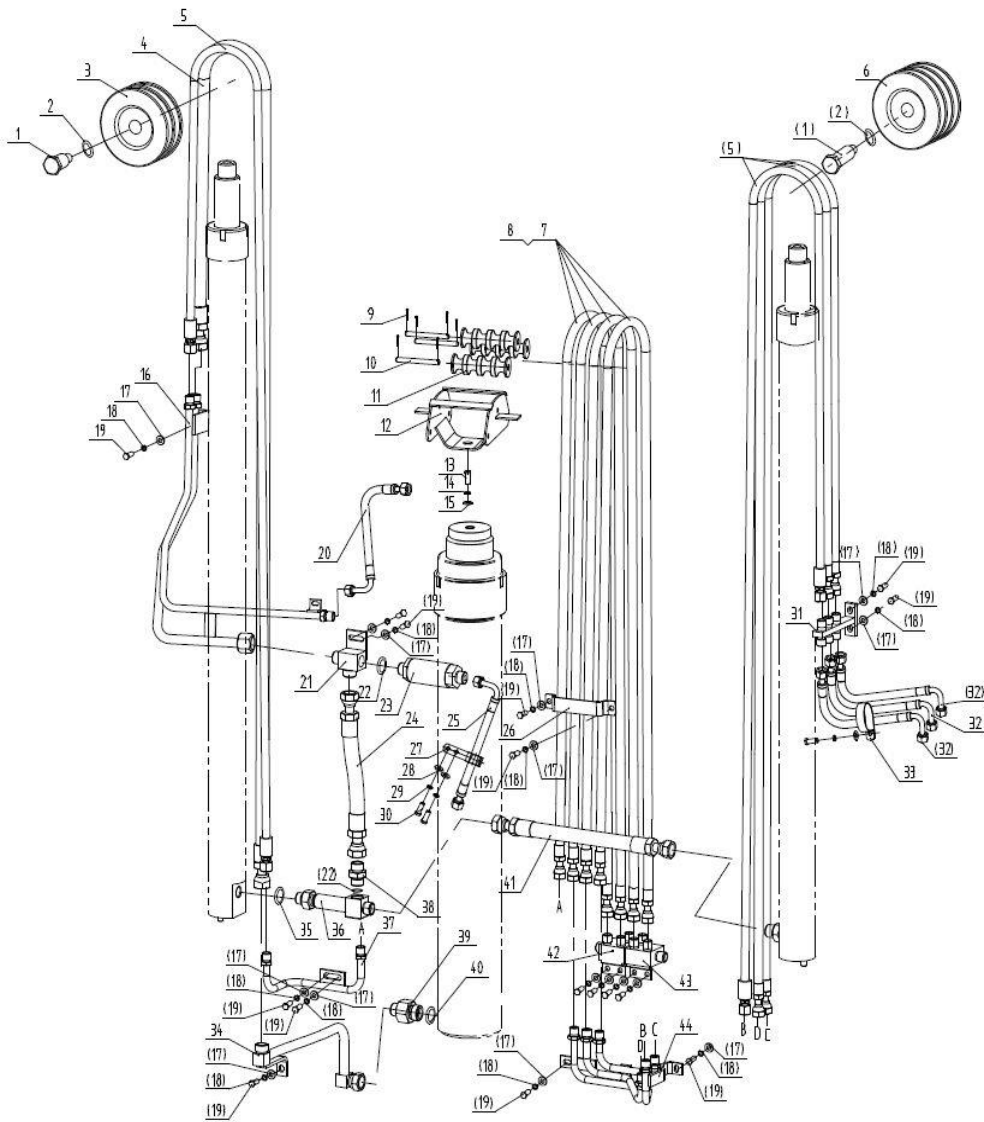

1	69016660	30386S-00003	Step bolt	2	
2	69000579	30386S-00004 (8)	Sleeve	4	
3	69024658	30488W2-00002	Three stage pulley I	1	
4	N/A	A20488-01000	Full free cylinder inlet oil hose	1	FBA20/25/30-JZ
-	N/A	A35788-01000	Full free cylinder inlet oil hose	1	FBA35-JZ
5	N/A	A20488S-01000	Side shift hose I	2	FBA20/25/30-JZ
-	N/A	A35788S-01000	Side shift hose I	2	FBA35-JZ
6	69034208	A30488SS-00001	Three stage pulley II	1	
7	N/A	A25788S-01000A	Side shift hose I	4	FBA20/25-JZ
-	N/A	A30788S-01000	Side shift hose I	4	FBA30-JZ
-	N/A	A35788S-02000	Side shift hose I	4	FBA35-JZ
8	N/A	A25788S-02000	Side shift hose II	4	FBA20/25-JZ
-	N/A	A30788S-01000	Side shift hose II	4	FBA30-JZ
-	N/A	A35788S-03000	Side shift hose II	4	FBA35-JZ
9	69005787	GB/T91-2*16	Cotter pin 2×16	6	
10	69042097	GB/T880-Φ8*120	Shaft Φ8×120	3	
11	69123554	A30488S-00001B	Pulley	3	
12	69115099	A30488S-01000A-Black	Roller bracket	1	
13	69000176	GB/T5783-M16*80-8.8J	Bolt M16×80	1	
14	69000056	GB/T93-16	Washer 16	1	
15	69000253	GB/T97.1-16	Washer 16	1	
16	69071497	A25788SS-01000	Transfer hose	1	FBA20/25-JZ
-	69077341	A30788SS-01000	Transfer hose	1	FBA30/35-JZ
17	69000259	GB/T97.1-8	Washer 8	16	
18	69000062	GB/T93-8	Washer 8	16	

图79/ Fig. 79

门架管路系统(三级全自由四联)/MAST HYDRAULIC SYSTEM(FULL FREE 3-STAGE MAST FOUR-THROW)

FBA20/25/30/35-JZ

序号	物料号	代号	名称	数量	备注
Item No.	ID.	Part No.	Description	Q'ty	Remart
19	69000309	GB/T5783-M8*16-8.8J	Bolt M8×16	16	

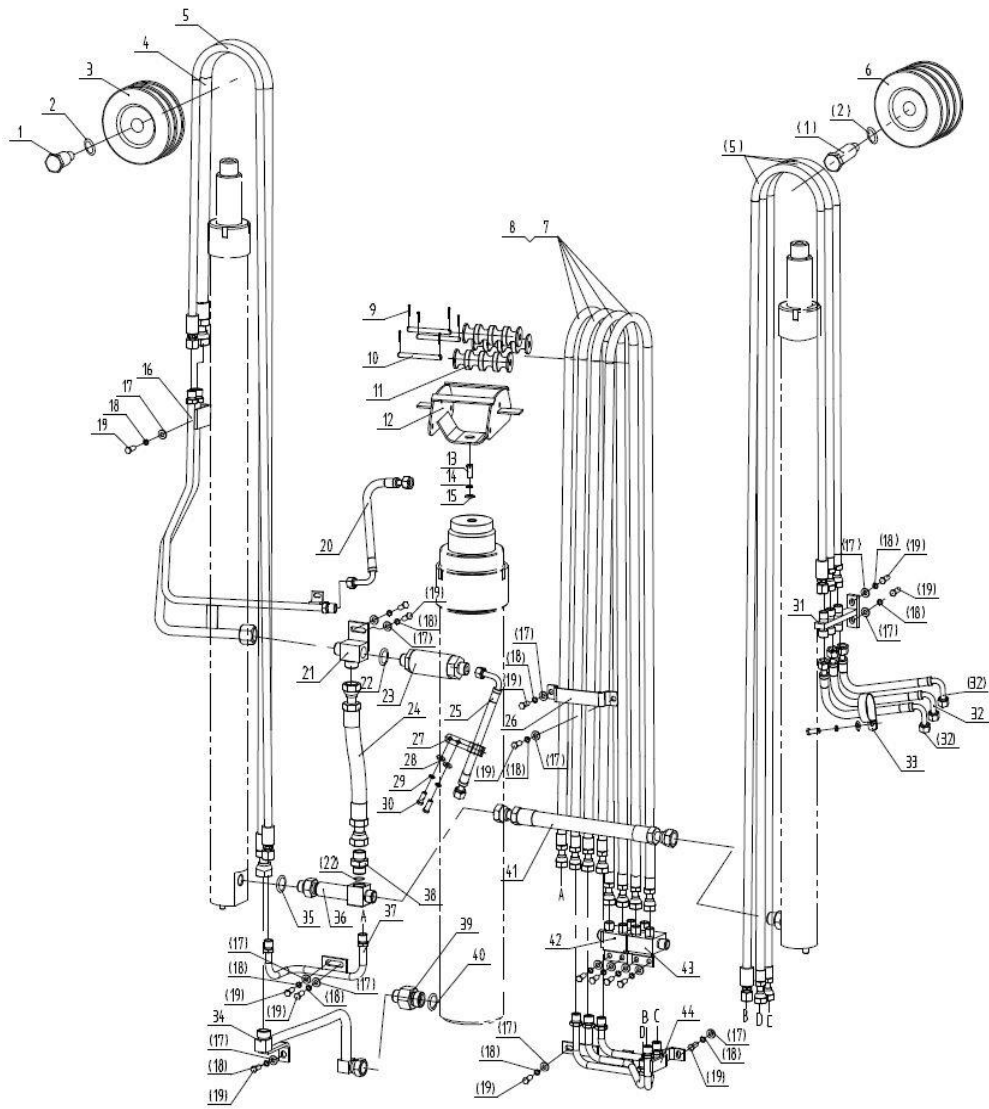

20	69131507	A25788SS-00001	Adjusting hose	1	
21	69016770	30388-02000	Speed limiting valve three way	1	
22	69022457	GB/T1235-24*2.4	O-ring 24×2.4	2	
23	69002920	20386-01000	Speed limiting valve	1	FBA20/25-JZ
-	69002922	30386-03000	Speed limiting valve	1	FBA30/35-JZ
24	69001493	30388-00001	Three way-three-way connect hose	1	
25	69070284	15388-00003	Valve-Speed limiting valve hose	1	
26	69042096	A30488S-00002	Pipe clamp	1	
27	69057149	20B88-00001	Pipe clamp	1	
28	69000258	GB/T97.1-6	Washer 6	3	
29	69000060	GB/T93-6	Washer 6	3	
30	69000190	GB/T5783-M6*16-8.8J	Bolt M6×16	3	
31	69071499	A25788SS-02000	Six way	1	FBA20/25-JZ
-	69024667	30488W2-02000	Six way	1	FBA30/35-JZ
32	69131506	A25788S-00001	Steering cylinder oil hose I	3	
33	69061179	GMS-DJR45	Clamp	1	
34	69071448	A25788-02000	Free cylinder inlet oil hose	1	FBA20/25-JZ
-	69034190	A30488-02000	Free cylinder inlet oil hose	1	FBA30/35-JZ
35	69124142	GB/T3452.1-17*2.65-G	O-ring 17×2.65	1	
36	69016646	30386-01000	Lifting cylinder Three way	1	
37	69129634	A25788SS-03000A	Four transfer seat I	1	FBA20/25-JZ
-	69129638	S20488SS-01000	Four transfer seat I	1	FBA30/35-JZ
38	69016767	30388-00003	Three way-three-way connector	1	
39	69006260	30388-00005	Free cylinder connector	1	取消, 厂家自带

图79/Fig. 79

门架管路系统(三级全自由四联)/MAST HYDRAULIC SYSTEM(FULL FREE 3-STAGE MAST FOUR-THROW)

FBA20/25/30/35-JZ

序号	物料号	代号	名称	数量	备注
Item No.	ID.	Part No.	Description	Q'ty	Remark
40	69018910	GB/T1235-30*3.1	O-ring 30×3.1	1	
41	69130621	A20488-00001	Lifting cylinder connect hose	1	FBA20/25-JZ

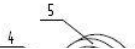

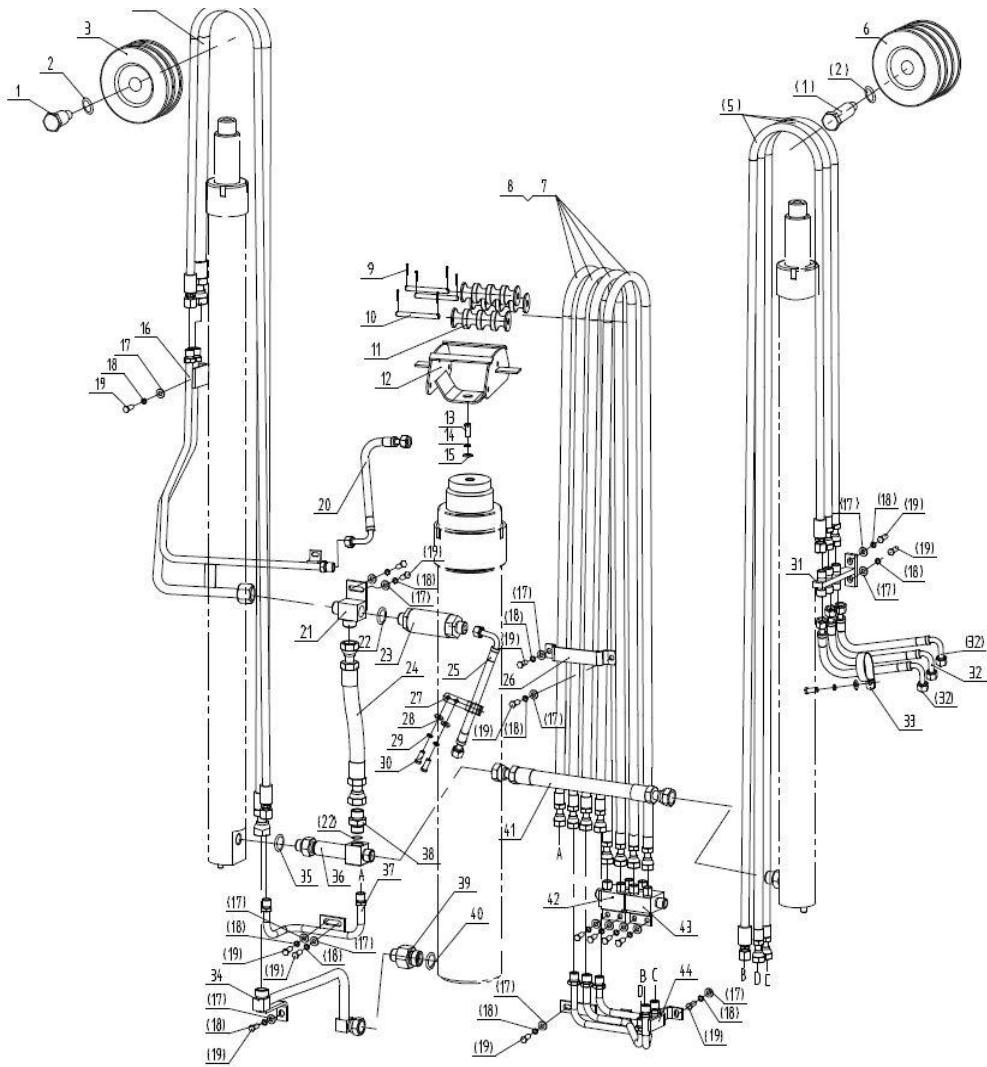

-	69121326	A30786-00001	H. P. hose	1	FBA30/35-JZ
42	69034214	A30488SS-04000	Four way II	1	
43	69034198	A30488S-04000	Four way I	1	
44	69129635	A25788SS-04000A	Four transfer seat II	1	FBA20/25-JZ
-	69129637	A30488SS-05000A	Four transfer seat II	1	FBA30/35-JZ

图80/ Fig. 80 标牌安装/ DECAL ASSEMBLE

FBA15/18/20/25/30/35-JZ

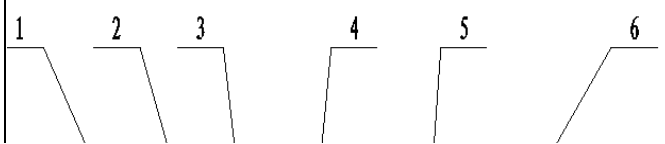

序号 Item No.	物料号 ID.	代号 Part No.	名称 Description	数量 Q'ty	备注 Remart
1	69136434	M3039100001	Safety decal	2	
2	69136445	M2579100001	Lubrication decal	1	
3	69000725	M3039100002-1	Mast decal	2	







图80/Fig. 80

标牌安装/ DECAL ASSEMBLE

FBA15/18/20/25/30/35-JZ

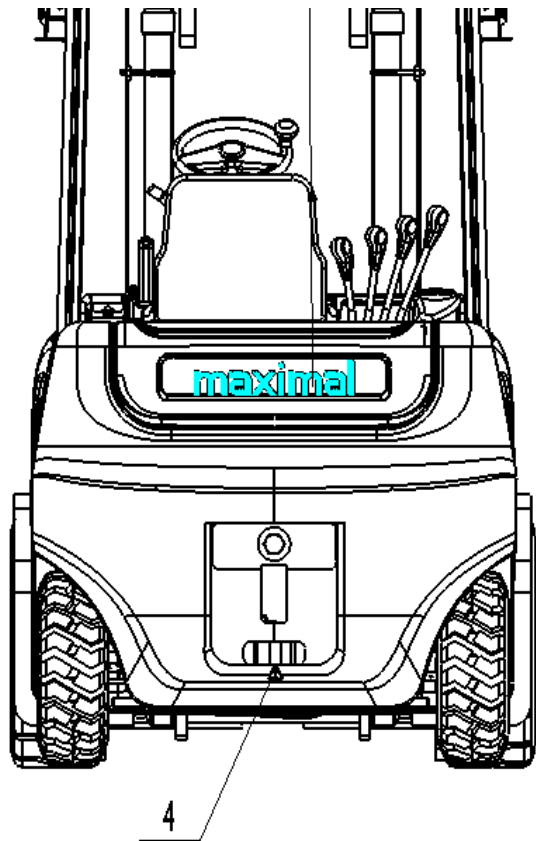
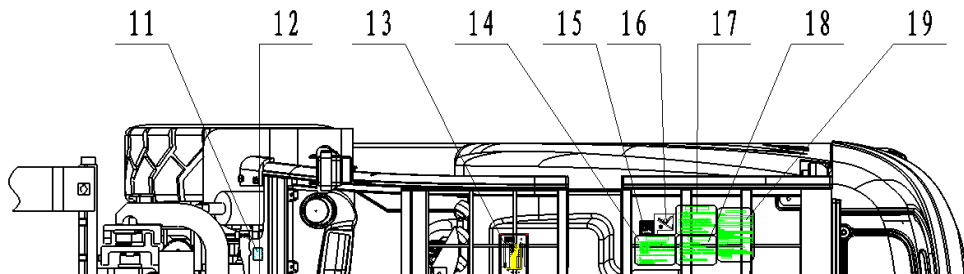
序号 Item No.	物料号 ID.	代号 Part No.	名称 Description	数量 Q'ty	备注 Remart
11	69085830	M2579100005	Name plate	1	
12	69136436	M3039100013	Standing forbidden decal	1	
13	69136448	A35791-00002	Load chart	1	FBA35-JZ
-	69136447	A30791-00002	Load chart	1	FBA30-JZ
-	69136446	A25791-00002	Load chart	1	FBA25-JZ
-	69087666	A20791-00002-1	Load chart	1	FBA20-JZ
-	69087596	A18791-00002-1	Load chart	1	FBA18-JZ
-	69087671	A15791-00002-1	Load chart	1	FBA15-JZ
14	69136432	M2579100011	Battery maintenance precautions	1	

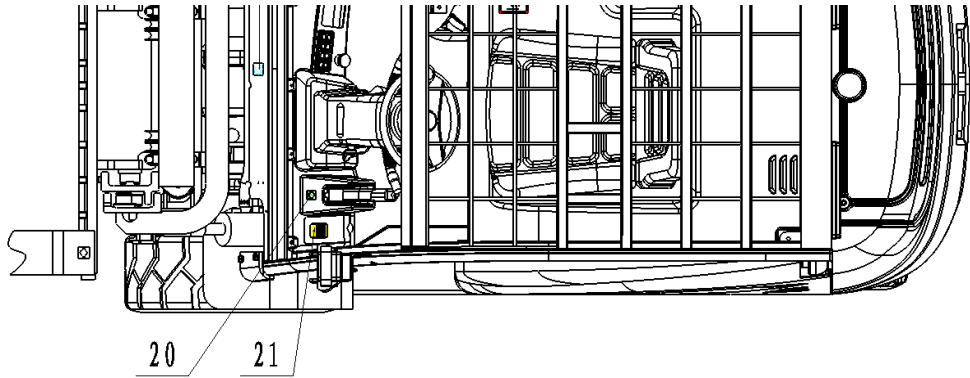



15	69136747	MJ30491-00010	Forbid hitching people decal	1	
16	69136433	M2579100013	Battery proof water proof	1	
17	69136430	M2579100009	Battery operation rules	1	
18	69136431	M2579100010	Charging instruction	1	
19	69136429	M2579100007	Operation instruction decal	1	
20	69136742	A30491-00004	Brake decal	1	
21	69136741	MJ30491-00003	Brake oil decal	1	

图80/Fig. 80 标牌安装/ DECAL ASSEMBLE

FBA15/18/20/25/30/35-JZ

序号	代号	名称	数量	备注
Item No.	Part No.	Description	Q'ty	Remart
22	69136752	MJ30491-00001	Hydraulic oil decal	1

